



Guidance For Classification And Construction

Part 1 Seagoing Ship

Volume P

GUIDANCE FOR CALCULATION OF INTERNAL COMBUSTION ENGINE CRANKSHAFT

2018

Biro Klasifikasi Indonesia



Guidance For Classification And Construction

Part 1 Seagoing Ship

Volume P

GUIDANCE FOR CALCULATION OF INTERNAL COMBUSTION ENGINE CRANKSHAFT

2018

Biro Klasifikasi Indonesia

Copyright © 2018 Biro Klasifikasi Indonesia
Jl. Yos Sudarso No. 38-40, Tanjung Priok
Jakarta 14320 - Indonesia
rules@bki.co.id
www.bki.co.id

The following Guidance come into force on 1st July 2018

Reproduction in whole or in part by any means, is subject to the permission in writing by Biro Klasifikasi Indonesia Head Office.

Foreword

This 2018 edition replaces the Guidance for Calculation of Diesel Engine Crankshaft (Pt.1, Vol.P) 1996 edition. In this 2018 edition, the title of the guidance changes to become Guidance for Calculation of Internal Combustion Engine Crankshaft and major changes have been made in whole of the guidance.

Section 1 consists of general provision include scope, field of application, principle of calculation and document to be submitted.

Section 2 consists of provision for calculations of internal combustion engine crankshaft.

Moreover, Annexes have been added to related Sections. Annex A is annexe to Definition Picture of stress concentration factor in crankshaft fillets, and Annex B is annexe to stress concentration factor and stress distribution at the edge of oil drillings Picture, and so Annex C is annexe to section 2.

The reference sources of the Guidance are mainly derived from IACS documents, and inputs from internal BKI.

This page intentionally left blank

Table of Contents

Foreword.....	iii
Table of Contents.....	v
Section 1 General	1-1
A. Scope.....	1-1
B. Field of Application.....	1-1
C. Principles of calculation.....	1-1
D. Drawing and particulars to be submitted.....	1-1
Section 2 Calculation	2-1
A. Calculation of Stresses.....	2-1
B. Evaluation of Stress Concentration Factors	2-8
C. Additional Bending Stresses	2-13
D. Calculation of Equivalent Alternating Stress	2-13
E. Calculation Fatigue Strength.....	2-14
F. Acceptability Criteria	2-15
G. Calculation of Shrink-Fits of Semi-Built Crankshafts.....	2-15
Annex A Definition of stress concentration factor in crankshaft fillets.....	A-1
Annex B Stress concentration factor and stress distribution at the edge of oil drillings.....	B-1
Annex C Alternative method for calculation of stress concentration factors in the web fillet radii of crankshafts by utilizing Finite Element Method	C-1
A. General.....	C-1
B. Model requirements.....	C-1
C. Load cases	C-3

This page intentionally left blank

Section 1 General

A.	Scope	1-1
B.	Field of Application	1-1
C.	Principles of calculation	1-1
D.	Drawing and particulars to be submitted	1-1

A. Scope

These Rules for the design of crankshafts are to be applied to I.C. engines for propulsion and auxiliary purposes, where the engines are capable of continuous operation at their rated power when running at rated speed. Where a crankshaft design involves the use of surface treated fillets, or when fatigue parameter influences are tested, or when working stresses are measured, the relevant documents with calculations/analysis are to be submitted to BKI in order to demonstrate equivalence to the Rules.

B. Field of Application

These Rules apply only to solid-forged and semi-built crankshafts of forged or cast steel, with one crank throw between main bearings.

C. Principles of calculation

The design of crankshafts is based on an evaluation of safety against fatigue in the highly stressed areas. The calculation is also based on the assumption that the areas exposed to highest stresses are:

- fillet transitions between the crankpin and web as well as between the journal and web,
- outlets of crankpin oil bores.

When journal diameter is equal or larger than the crankpin one, the outlets of main journal oil bores are to be formed in a similar way to the crankpin oil bores, otherwise separate documentation of fatigue safety may be required.

Calculation of crankshaft strength consists initially in determining the nominal alternating bending (see [Sec.2.A.1](#)) and nominal alternating torsional stresses (see [Sec.2.A.2](#)) which, multiplied by the appropriate stress concentration factors (see [Sec.2.B](#)), result in an equivalent alternating stress (uni-axial stress) (see [Sec.2.D](#)). This equivalent alternating stress is then compared with the fatigue strength of the selected crankshaft material (see [Sec.2.E](#)). This comparison will show whether or not the crankshaft concerned is dimensioned adequately (see [Sec.2.F](#)).

D. Drawing and particulars to be submitted

For the calculation of crankshafts, the documents and particulars listed below are to be submitted:

- crankshaft drawing (which must contain all data in respect of the geometrical configurations of the crankshaft)
- type designation and kind of engine (in-line engine or V-type engine with adjacent connecting-rods, forked connecting-rod or articulated-type connecting-rod)
- operating and combustion method (2-stroke or 4-stroke cycle/direct injection, precombustion chamber, etc.)

- number of cylinders
- rated power [kW]
- rated engine speed [r/min]
- direction of rotation (see Fig. 1.1)
- firing order with the respective ignition intervals and, where necessary,
- V-angle α_v [°] (see Fig. 1.1)

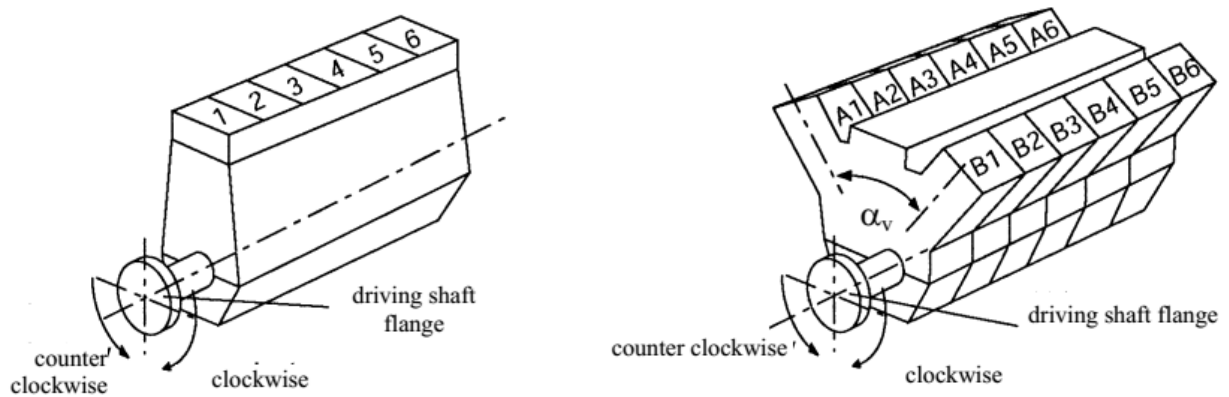

Fig. 1.1 Designation of the cylinders

- cylinder diameter [mm]
- stroke [mm]
- maximum net cylinder pressure P_{max} [bar]
- charge air pressure [bar]
 (before inlet valves or scavenge ports, whichever applies)
- connecting-rod length L_H [mm]
- all individual reciprocating masses acting on one crank [kg]
- digitized gas pressure curve presented at equidistant intervals [bar versus Crank Angle] (at least every 5° CA)
- for engines with articulated-type connecting-rod (see Fig. 1.2)
 - distance to link point L_A [mm]
 - link angle α_N [°]
- connecting-rod length L_N [mm]

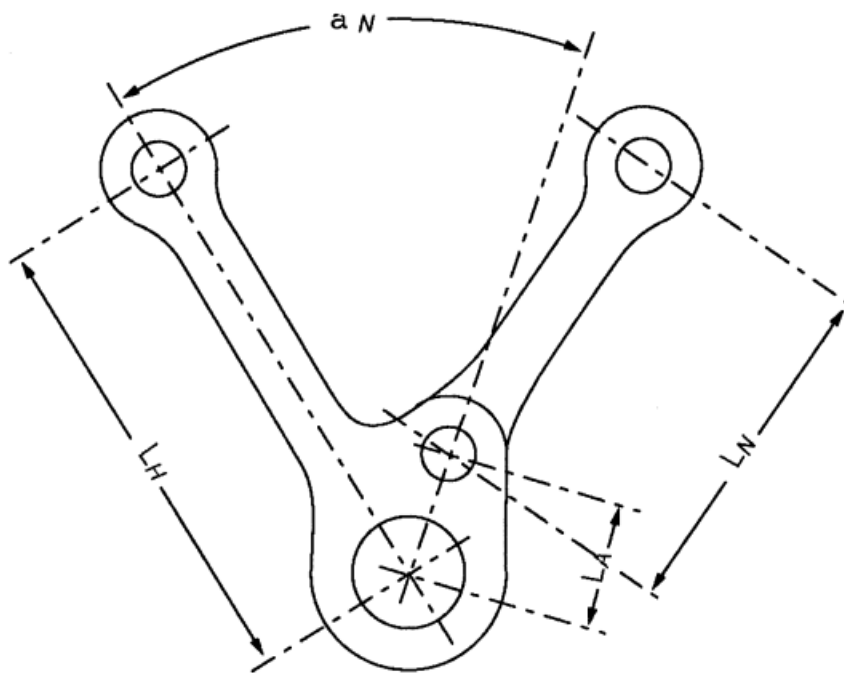

Fig. 1.2 Articulated-type connecting-rod

- details of crankshaft material
 - material designation (according to ISO, EN, DIN, AISI, etc.)
 - mechanical properties of material (minimum values obtained from longitudinal test specimens)
 - tensile strength [N/mm²]
 - yield strength [N/mm²]
 - reduction in area at break [%]
 - elongation A5 [%]
 - impact energy – KV [J]
 - type of forging (free form forged, continuous grain flow forged, drop-forged, etc; with description of the forging process)
- Every surface treatment affecting fillets or oil holes shall be subject to special consideration
- Particulars of alternating torsional stress calculations, see item B.

This page intentionally left blank

Section 2 Calculation

A.	Calculation of Stresses	2-1
B.	Evaluation of Stress Concentration Factors	2-8
C.	Additional Bending Stresses.....	2-13
D.	Calculation of Equivalent Alternating Stress	2-13
E.	Calculation Fatigue Strength.....	2-14
F.	Acceptability Criteria	2-15
G.	Calculation of Shrink-Fits of Semi-Built Crankshafts	2-15

A. Calculation of Stresses

1. Calculation of alternating stresses due to bending moments and radial forces

1.1 Assumptions

The calculation is based on a statically determined system, composed of a single crankthrow supported in the centre of adjacent main journals and subject to gas and inertia forces. The bending length is taken as the length between the two main bearing midpoints (distance L_3 , see [Fig. 2.1](#) and [Fig. 2.2](#)).

The bending moments M_{BR} , M_{BT} are calculated in the relevant section based on triangular bending moment diagrams due to the radial component F_R and tangential component F_T of the connecting-rod force, respectively (see [Fig. 2.1](#)).

For crankthrows with two connecting-rods acting upon one crankpin the relevant bending moments are obtained by superposition of the two triangular bending moment diagrams according to phase (see [Fig. 2.2](#)).

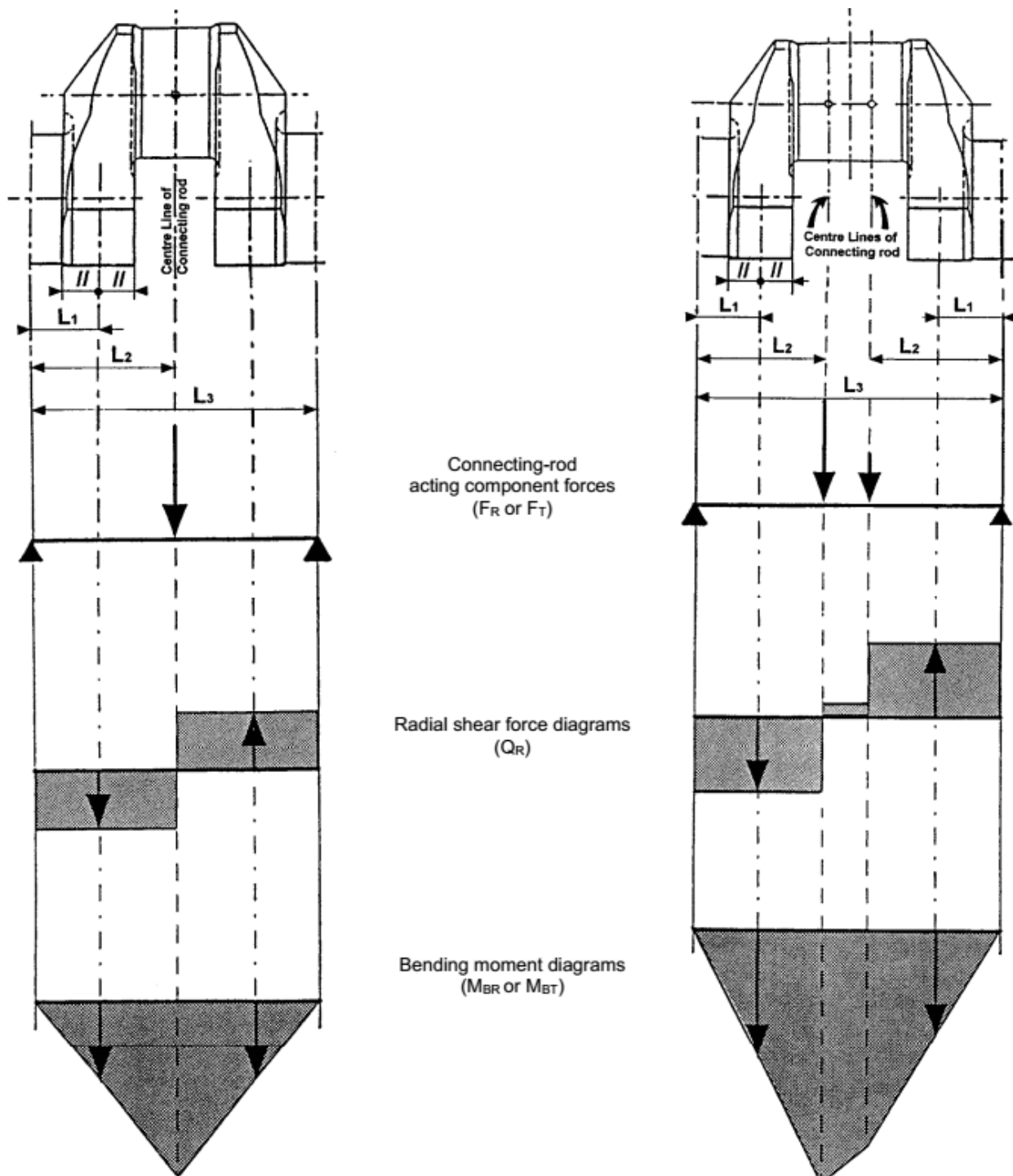

Fig. 2.1 Crankthrow for in line engine

Fig. 2.2 Crankthrow for Vee engine with 2 adjacent connecting-rods

- L1 = Distance between main journal centre line and crank web centre
(see also Fig. 2.3 for crankshaft without overlap)
- L2 = Distance between main journal centre line and connecting-rod centre
- L3 = Distance between two adjacent main journal centre lines

1.1.1 Bending moments and radial forces acting in web

The bending moment M_{BRF} and the radial force Q_{RF} are taken as acting in the centre of the solid web (distance L_1) and are derived from the radial component of the connecting-rod force. The alternating bending and compressive stresses due to bending moments and radial forces are to be related to the cross-section of the crankweb. This reference section results from the web thickness W and the web width B (see Fig. 2.3). Mean stresses are neglected.

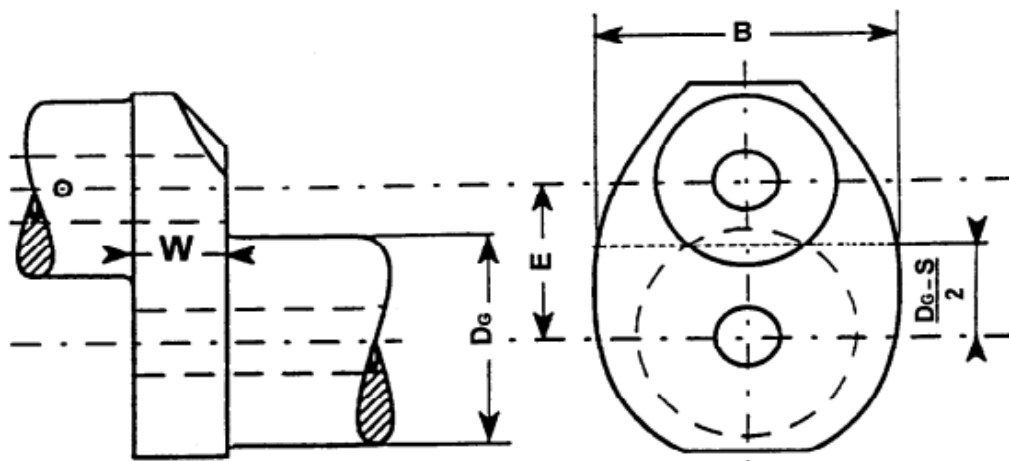

Overlapped crankshaft

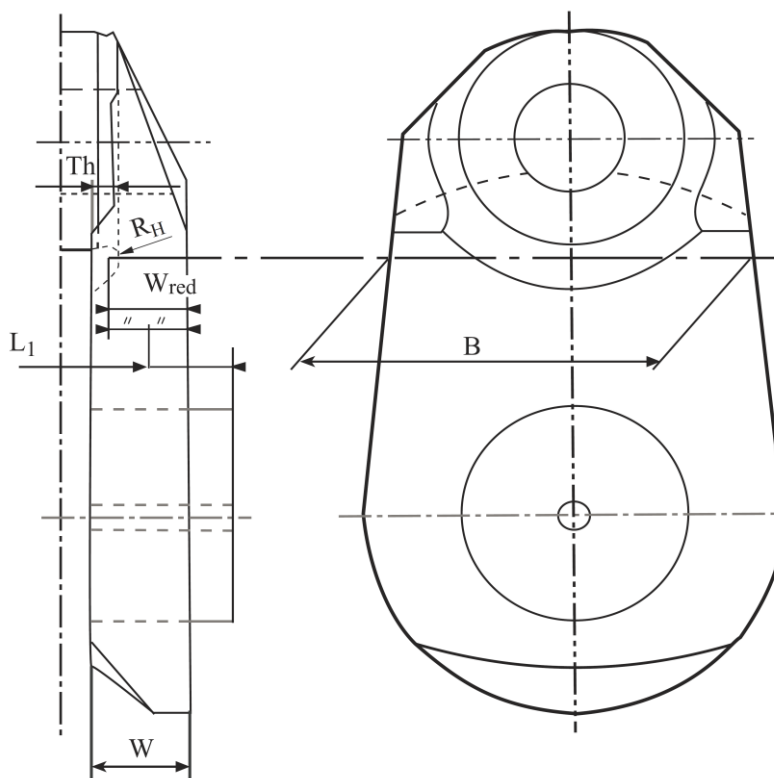

Crankshaft without overlap

Fig. 2.3 Reference area of crankweb cross section

1.1.2 Bending acting in outlet of crankpin oil bore

The two relevant bending moments are taken in the crankpin cross-section through the oil bore.

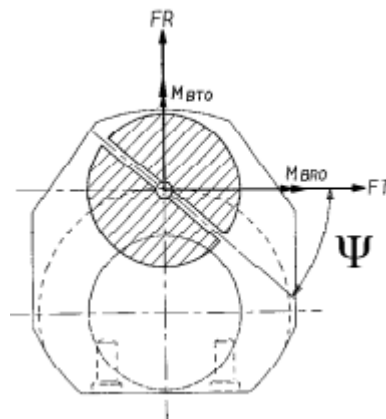

M_{BRO} = the bending moment of the radial component of the connecting-rod force

M_{BTO} = the bending moment of the tangential component of the connecting-rod force

Fig. 2.4 Crankpin section through the oil bore

The alternating stresses due to these bending moments are to be related to the cross sectional area of the axially bored crankpin.

Mean bending stresses are neglected.

1.2 Calculation of nominal alternating bending and compressive stresses in web

The radial and tangential forces due to gas and inertia loads acting upon the crankpin at each connecting-rod position will be calculated over one working cycle.

Using the forces calculated over one working cycle and taking into account of the distance from the main bearing midpoint, the time curve of the bending moments M_{BRF} , M_{BRO} , M_{BTO} and radial forces Q_{RF} defined in 1.1.1 and 1.1.2 will then be calculated.

In case of V-type engines, the bending moments - progressively calculated from the gas and inertia forces - of the two cylinders acting on one crankthrow are superposed according to phase. Different designs (forked connecting-rod, articulated-type connecting-rod or adjacent connecting-rods) shall be taken into account.

Where there are cranks of different geometrical configurations in one crankshaft, the calculation is to cover all crank variants.

The decisive alternating values will then be calculated according to:

$$X_N = \pm \frac{1}{2} [X_{\max} - X_{\min}]$$

where:

X_N = considered as alternating force, moment or stress

X_{\max} = maximum value within one working cycle

X_{\min} = minimum value within one working cycle

1.2.1 Nominal alternating bending and compressive stresses in web cross section

The calculation of the nominal alternating bending and compressive stresses is as follows:

$$\sigma_{\text{BFN}} = \pm \frac{M_{\text{BRFN}}}{W_{\text{eqw}}} \cdot 10^3 \cdot K_e$$

$$\sigma_{\text{QFN}} = \pm \frac{Q_{\text{RFN}}}{F} \cdot K_e$$

where:

σ_{BFN} = nominal alternating bending stress related to the web [N/mm²]

M_{BRFN} = alternating bending moment related to the centre of the web (see Fig. 2.1 and Fig. 2.2) [Nm]

$$M_{\text{BRFN}} = \pm \frac{1}{2} [M_{\text{BRFmax}} - M_{\text{BRFmin}}]$$

W_{eqw} = section modulus related to cross-section of web [mm³]

$$W_{\text{eqw}} = \frac{B \cdot W^2}{6}$$

K_e = empirical factor considering to some extent the influence of adjacent crank and bearing restraint with:

$$K_e = 0,8 \text{ for 2-stroke engines}$$

$$K_e = 1,0 \text{ for 4-stroke engines}$$

σ_{QFN} = nominal alternating compressive stress due to radial force related to the web [N/mm²]

Q_{RFN} = alternating radial force related to the web (see Fig. 2.1 and Fig. 2.2) [N]

$$Q_{\text{RFN}} = \pm \frac{1}{2} [Q_{\text{RFmax}} - Q_{\text{RFmin}}]$$

F = area related to cross-section of web [mm²]

$$F = B \cdot W$$

1.2.2 Nominal alternating bending stress in outlet of crankpin oil bore

The calculation of nominal alternating bending stress is as follows:

$$\sigma_{\text{BON}} = \pm \frac{M_{\text{BON}}}{W_e} \cdot 10^3$$

where:

σ_{BON} = nominal alternating bending stress related to the crank pin diameter [N/mm²]

M_{BON} = alternating bending moment calculated at the outlet of crankpin oil bore [Nm]

$$M_{\text{BON}} = \pm \frac{1}{2} [M_{\text{BOmax}} - M_{\text{BOmin}}] \text{ with,}$$

$$M_{\text{BO}} = (M_{\text{BTO}} \cdot \cos \psi + M_{\text{BRO}} \cdot \sin \psi) \text{ and}$$

ψ = angular position (see Fig. 2.4) [°]

W_e = section modulus related to cross-section of axially bored crankpin [mm³]

$$W_e = \frac{\pi}{32} \left[\frac{D^4 - D_{BH}^4}{D} \right]$$

1.3 Calculation of alternating bending stresses in fillets

The calculation of stresses is to be carried out for the crankpin fillet as well as for the journal fillet.

For the crankpin fillet:

$$\sigma_{BH} = \pm (\alpha_B \cdot \sigma_{BFN})$$

where:

σ_{BH} = alternating bending stress in crankpin fillet [N/mm²]

α_B = stress concentration factor for bending in crankpin fillet (determination - see item B.)

For the journal fillet (not applicable to semi-built crankshaft):

$$\sigma_{BG} = \pm (\beta_B \cdot \sigma_{BFN} + \beta_Q \cdot \sigma_{QFN})$$

where:

σ_{BG} = alternating bending stress in journal fillet [N/mm²]

β_B = stress concentration factor for bending in journal fillet (determination see item B.)

β_Q = stress concentration factor for compression due to radial force in journal fillet (determination - see item B.)

1.4 Calculation of alternating bending stresses in outlet of crankpin oil bore

$$\sigma_{BO} = \pm (\gamma_B \cdot \sigma_{BON})$$

where:

σ_{BO} = alternating bending stress in outlet of crankpin oil bore [N/mm²]

γ_B = stress concentration factor for bending in crankpin oil bore (determination - see item B.)

2. Calculation of alternating torsional stresses

2.1 General

The calculation for nominal alternating torsional stresses is to be undertaken by the engine manufacturer according to the information contained in item 2.2.

The manufacturer shall specify the maximum nominal alternating torsional stress.

2.2 Calculation of nominal alternating torsional stresses

The maximum and minimum torques are to be ascertained for every mass point of the complete dynamic system and for the entire speed range by means of a harmonic synthesis of the forced vibrations from the 1st order up to and including the 15th order for 2-stroke cycle engines and from the 0,5th order up to and including the 12th order for 4-stroke cycle engines. Whilst doing so, allowance must be made for the damping that exists in the system and for unfavourable conditions (misfiring¹ in one of the cylinders). The speed step calculation shall be selected in such a way that any resonance found in the operational speed range of the engine shall be detected.

Where barred speed ranges are necessary, they shall be arranged so that satisfactory operation is possible despite their existence. There are to be no barred speed ranges above a speed ratio of $\lambda \geq 0,8$ for normal firing conditions.

The values received from such calculation are to be submitted to BKI.

The nominal alternating torsional stress in every mass point, which is essential to the assessment, results from the following equation:

$$\tau_N = \pm \frac{M_{TN}}{W_p} \cdot 10^3$$

$$M_{TN} = \pm \frac{1}{2} [M_{Tmax} - M_{Tmin}]$$

$$W_p = \frac{\pi}{16} \left(\frac{D^4 - D_{BH}^4}{D} \right) \quad \text{or} \quad W_p = \frac{\pi}{16} \left(\frac{D_G^4 - D_{BG}^4}{D_G} \right)$$

where:

τ_N	=	nominal alternating torsional stress referred to crankpin or journal [N/mm ²]
M_{TN}	=	maximum alternating torque [Nm]
W_p	=	polar section modulus related to cross-section of axially bored crankpin or bored journal [mm ³]
M_{Tmax}	=	maximum value of the torque [Nm]
M_{Tmin}	=	minimum value of the torque [Nm]

For the purpose of the crankshaft assessment, the nominal alternating torsional stress considered in further calculations is the highest calculated value, according to above method, occurring at the most torsionally loaded mass point of the crankshaft system.

Where barred speed ranges exist, the torsional stresses within these ranges are not to be considered for assessment calculations.

The approval of crankshaft will be based on the installation having the largest nominal alternating torsional stress (but not exceeding the maximum figure specified by engine manufacturer).

Thus, for each installation, it is to be ensured by suitable calculation that this approved nominal alternating torsional stress is not exceeded. This calculation is to be submitted for assessment.

¹ Misfiring is defined as cylinder condition when no combustion occurs but only compression cycle.

2.3 Calculation of alternating torsional stresses in fillets and outlet of crankpin oil bore

The calculation of stresses is to be carried out for the crankpin fillet, the journal fillet and the outlet of the crankpin oil bore.

For the crankpin fillet:

$$\tau_H = \pm (\alpha_T \cdot \tau_N)$$

where:

- τ_H = alternating torsional stress in crankpin fillet [N/mm²]
- α_T = stress concentration factor for torsion in crankpin fillet (determination see item B.)
- τ_N = nominal alternating torsional stress related to crankpin diameter [N/mm²]

For the journal fillet (not applicable to semi-built crankshafts):

$$\tau_G = (\beta_T \cdot \tau_N)$$

where:

- τ_G = alternating torsional stress in journal fillet [N/mm²]
- β_T = stress concentration factor for torsion in journal fillet (determination see item B.)
- τ_N = nominal alternating torsional stress related to journal diameter [N/mm²]

For the outlet of crankpin oil bore:

$$\sigma_{TO} = \pm (\gamma_T \cdot \tau_N)$$

where:

- σ_{TO} = alternating stress in outlet of crankpin oil bore due to torsion [N/mm²]
- γ_T = stress concentration factor for torsion in outlet of crankpin oil bore (determination- see item B.)
- τ_N = nominal alternating torsional stress related to crankpin diameter [N/mm²]

B. Evaluation of Stress Concentration Factors

1. General

The stress concentration factors are evaluated by means of the formulae according to items 2. to 4. applicable to the fillets and crankpin oil bore of solid forged web-type crankshafts and to the crankpin fillets of semi-built crankshafts only. It must be noticed that stress concentration factor formulae concerning the oil bore are only applicable to a radially drilled oil hole. All formulae are based on investigations of FVV (Forschungsvereinigung Verbrennungskraftmaschinen) for fillets and on investigations of ESDU (Engineering Science Data Unit) for oil holes.

Where the geometry of the crankshaft is outside the boundaries of the analytical stress concentration factors (SCF) the calculation method detailed in Annex C may be undertaken.

All crank dimensions necessary for the calculation of stress concentration factors are shown in Fig. 2.5.

The stress concentration factor for bending (α_B , β_B) is defined as the ratio of the maximum equivalent stress (VON MISES) occurring in the fillets under bending load to the nominal bending stress related to the web cross-section (see Annex A).

The stress concentration factor for compression (β_α) in the journal fillet is defined as the ratio of the maximum equivalent stress (VON MISES) - occurring in the fillet due to the radial force - to the nominal compressive stress related to the web cross-section.

The stress concentration factor for torsion (α_T , β_T) is defined as the ratio of the maximum equivalent shear stress occurring in the fillets under torsional load – to the nominal torsional stress related to the axially bored crankpin or journal cross-section (see Annex A).

The stress concentration factors for bending (γ_B) and torsion (γ_T) are defined as the ratio of the maximum principal stress occurring at the outlet of the crankpin oil-hole under bending and torsional loads to the corresponding nominal stress related to the axially bored crankpin cross section (see Annex B).

When reliable measurements and/or calculations are available, which can allow direct assessment of stress concentration factors, the relevant documents and their analysis method have to be submitted to BKI in order to demonstrate their equivalence to present rules evaluation.

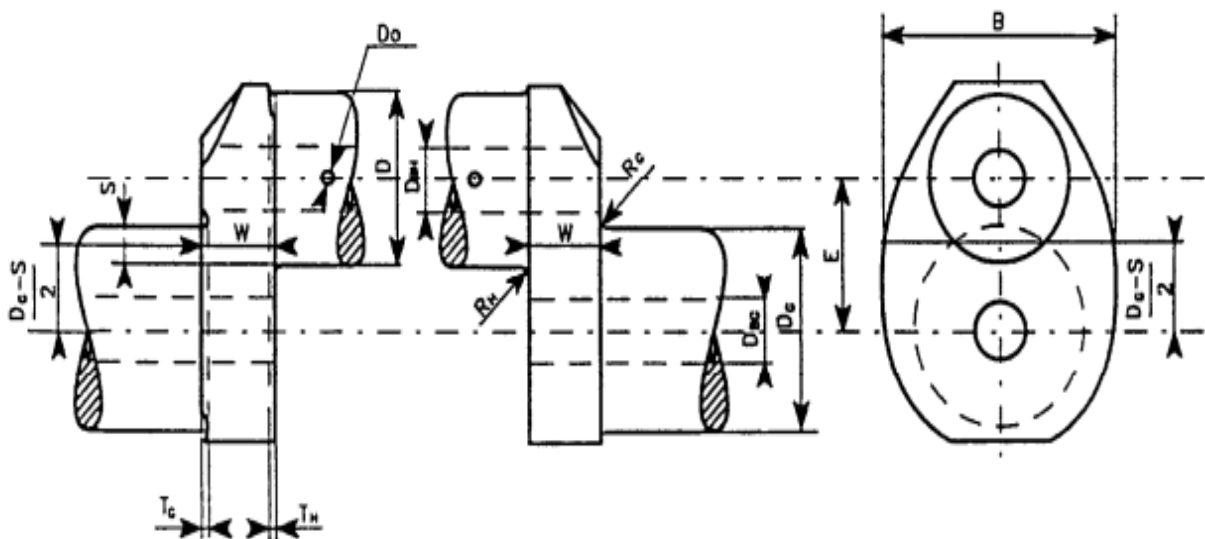

Fig. 2.5 Crank dimensions

Actual dimensions:

- D = crankpin diameter [mm]
- D_{BH} = diameter of axial bore in crankpin [mm]
- D_o = diameter of oil bore in crankpin [mm]
- R_H = fillet radius of crankpin [mm]
- T_H = recess of crankpin fillet [mm]
- D_G = journal diameter [mm]
- D_{BG} = diameter of axial bore in journal [mm]

R_G = fillet radius of journal [mm]

T_G = recess of journal fillet [mm]

E = pin eccentricity [mm]

S = pin overlap [mm]

$$S = \frac{D + D_G}{2} - E$$

W^* = web thickness [mm]

B^* = web width [mm]

* In the case of 2 stroke semi-built crankshafts:

- when $T_H > R_H$, the web thickness must be considered as equal to:

$$W_{red} = W - (T_H - R_H) \text{ [refer to Fig. 2.3]}$$

- web width B must be taken in way of crankpin fillet radius centre according to Fig. 2.3

The following related dimensions will be applied for the calculation of stress concentration factors in:

Crankpin fillet		Journal fillet	
$r = R_H / D$		$r = R_G / D$	
s	=	S / D	
w	=	W/D crankshafts with overlap	
		W_{red}/D crankshafts without overlap	
b	=	B/D	
d_o	=	D_o/D	
d_G	=	D_{BG}/D	
d_H	=	D_{BH}/D	
t_H	=	T_H/D	
t_G	=	T_G/D	

Stress concentration factors are valid for the ranges of related dimensions for which the investigations have been carried out. Ranges are as follows:

$$s \leq 0,5$$

$$0,2 \leq w \leq 0,8$$

$$1,1 \leq b \leq 2,2$$

$$0,03 \leq r \leq 0,13$$

$$0 \leq d_G \leq 0,8$$

$$0 \leq d_H \leq 0,8$$

$$0 \leq d_o \leq 0,2$$

Low range of s can be extended down to large negative values provided that:

- If calculated $f(\text{recess}) < 1$ then the factor $f(\text{recess})$ is not to be considered ($f(\text{recess}) = 1$)
- If $s < -0,5$ then $f(s,w)$ and $f(r,s)$ are to be evaluated replacing actual value of s by $-0,5$.

2. Crankpin fillet

The stress concentration factor for bending (α_B) is:

$$\alpha_B = 2,6914 \cdot f(s, w) \cdot f(w) \cdot f(b) \cdot f(r) \cdot f(d_G) \cdot f(d_H) \cdot f(\text{recess})$$

where:

$$f(s,w) = -4,1883 + 29,2004 \cdot w - 77,5925 \cdot w^2 + 91,9454 \cdot w^3 - 40,0416 \cdot w^4 + (1-s) \cdot (9,5440 - 58,3480 \cdot w + 159,3415 \cdot w^2 - 192,5846 \cdot w^3 + 85,2916 \cdot w^4) + (1-s)^2 \cdot (-3,8399 + 25,0444 \cdot w - 70,5571 \cdot w^2 + 87,0328 \cdot w^3 - 39,1832 \cdot w^4)$$

$$F(w) = 2,1790 \cdot w^{0,7171}$$

$$f(b) = 0,6840 - 0,0077 \cdot b + 0,1473 \cdot b^2$$

$$f(r) = 0,2081 \cdot r^{(-0,5231)}$$

$$f(d_G) = 0,9993 + 0,27 \cdot d_G - 1,0211 \cdot d_G^2 + 0,5306 \cdot d_G^3$$

$$f(d_H) = 0,9978 + 0,3145 \cdot d_H - 1,5241 \cdot d_H^2 + 2,4147 \cdot d_H^3$$

$$f(\text{recess}) = 1 + (t_H + t_G) \cdot (1,8 + 3,2 \cdot s)$$

The stress concentration factor for torsion (α_T) is:

$$\alpha_T = 0,8 \cdot f(r,s) \cdot f(b) \cdot f(w)$$

where:

$$f(r,s) = r^{(-0,322 + 0,1015 \cdot (1-s))}$$

$$f(b) = 7,8955 - 10,654 \cdot b + 5,3482 \cdot b^2 - 0,857 \cdot b^3$$

$$f(w) = w^{(-0,145)}$$

3. Journal fillet (not applicable to semi-built crankshaft)

The stress concentration factor for bending (β_B) is:

$$\beta_B = 2,7146 \cdot f_B(s,w) \cdot f_B(w) \cdot f_B(b) \cdot f_B(r) \cdot f_B(d_G) \cdot f_B(d_H) \cdot f(\text{recess})$$

where:

$$f_B(s,w) = -1,7625 + 2,9821 \cdot w - 1,5276 \cdot w^2 + (1-s) \cdot (5,1169 - 5,8089 \cdot w + 3,1391 \cdot w^2) + (1-s)^2 \cdot (-2,1567 + 2,3297 \cdot w - 1,2952 \cdot w^2)$$

$$f_B(w) = 2,422 \cdot w^{0,7548}$$

$$f_B(b) = 0,5616 + 0,1197 \cdot b + 0,1176 \cdot b^2$$

$$f_B(r) = 0,1908 \cdot r^{(-0,5568)}$$

$$f_B(d_G) = 1,0012 - 0,6441 \cdot d_G + 1,2265 \cdot d_G^2$$

$$f_B(d_H) = 1,0022 - 0,1903 \cdot d_H + 0,0073 \cdot d_H^2$$

$$f(\text{recess}) = 1 + (t_H + t_G) \cdot (1,8 + 3,2 \cdot s)$$

The stress concentration factor for compression (β_Q) due to the radial force is:

$$\beta_Q = 3,0128 \cdot f_Q(s) \cdot f_Q(w) \cdot f_Q(b) \cdot f_Q(r) \cdot f_Q(d_H) \cdot f(\text{recess})$$

where:

$$f_Q(s) = 0,4368 + 2,1630 \cdot (1 - s) - 1,5212 \cdot (1 - s)^2$$

$$f_Q(w) = \frac{w}{0,0637 + 0,9369 \cdot w}$$

$$f_Q(b) = -0,5 + b$$

$$f_Q(r) = 0,5331 \cdot r - 0,2038$$

$$f_Q(d_H) = 0,9937 - 1,1949 \cdot d_H + 1,7373 \cdot d_H^2$$

$$f(\text{recess}) = 1 + (t_H + t_G) \cdot (1,8 + 3,2 \cdot s)$$

The stress concentration factor for torsion (β_T) is:

$$\beta_T = \alpha_T$$

if the diameters and fillet radii of crankpin and journal are the same.

If crankpin and journal diameters and/or radii are of different sizes

$$\beta_T = 0,8 \cdot f(r,s) \cdot f(b) \cdot f(w)$$

where:

$f(r,s)$, $f(b)$ and $f(w)$ are to be determined in accordance with item 2. (see calculation of α_T), however, the radius of the journal fillet is to be related to the journal diameter:

$$r = \frac{R_G}{D_G}$$

4. Outlet of crankpin oil bore

The stress concentration factor for bending (γ_B) is:

$$\gamma_B = 3 - 5,88 \cdot d_o + 34,6 \cdot d_o^2$$

The stress concentration factor for torsion (γ_T) is:

$$\gamma_T = 4 - 6 \cdot d_o + 30 \cdot d_o^2$$

C. Additional Bending Stresses

In addition to the alternating bending stresses in fillets (see item A.1.3) further bending stresses due to misalignment and bedplate deformation as well as due to axial and bending vibrations are to be considered by applying σ_{add} as given by Table 2.1:

Table 2.1 Additional bending stress

Type of engine	σ_{add} [N/mm ²]
Crosshead engines	$\pm 30^{(*)}$
Trunk piston engines	± 10
^(*) The additional stress of ± 30 N/mm ² is composed of two components: 1) an additional stress of ± 20 N/mm ² resulting from axial vibration 2) an additional stress of ± 10 N/mm ² resulting from misalignment / bedplate deformation	

It is recommended that a value of ± 20 N/mm² be used for the axial vibration component for assessment purposes where axial vibration calculation results of the complete dynamic system (engine/ shafting/ gearing/ propeller) are not available. Where axial vibration calculation results of the complete dynamic system are available, the calculated figures may be used instead.

D. Calculation of Equivalent Alternating Stress

1. General

In the fillets, bending and torsion lead to two different biaxial stress fields which can be represented by a Von Mises equivalent stress with the additional assumptions that bending and torsion stresses are time phased and the corresponding peak values occur at the same location (see Annex A).

As a result the equivalent alternating stress is to be calculated for the crankpin fillet as well as for the journal fillet by using the Von Mises criterion.

At the oil hole outlet, bending and torsion lead to two different stress fields which can be represented by an equivalent principal stress equal to the maximum of principal stress resulting from combination of these two stress fields with the assumption that bending and torsion are time phased (see Annex B).

The above two different ways of equivalent stress evaluation both lead to stresses which may be compared to the same fatigue strength value of crankshaft assessed according to Von Mises criterion.

2. Equivalent alternating stress

The equivalent alternating stress is calculated in accordance with the formulae given.

For the crankpin fillet:

$$\sigma_v = \pm \sqrt{(\sigma_{BH} + \sigma_{add})^2 + 3 \cdot \tau_H^2}$$

For the journal fillet:

$$\sigma_v = \pm \sqrt{(\sigma_{BG} + \sigma_{add})^2 + 3 \cdot \tau_G^2}$$

For the outlet of crankpin oil bore:

$$\sigma_v = \pm \frac{1}{2} \sigma_{BO} \cdot \left[1 + 2 \sqrt{1 + \frac{9}{4} \left(\frac{\sigma_{TO}}{\sigma_{BO}} \right)^2} \right]$$

where:

σ_v = equivalent alternating stress [N/mm²]

for other parameters see items [B.1.1.3](#), [B.2.2.3](#) and [D](#).

E. Calculation Fatigue Strength

The fatigue strength is to be understood as that value of equivalent alternating stress (Von Mises) which a crankshaft can permanently withstand at the most highly stressed points. The fatigue strength may be evaluated by means of the following formulae.

Related to the crankpin diameter:

$$\sigma_{DW} = \pm K \cdot (0,42 \cdot \sigma_B + 39,3) \cdot \left[0,264 + 1,07 \cdot D^{-0,2} + \frac{785 - \sigma_B}{4900} + \frac{196}{\sigma_B} \cdot \sqrt{\frac{1}{R_x}} \right]$$

with:

R_x = R_H in the fillet area
 R_x = $D_o/2$ in the oil bore area

Related to the journal diameter:

$$\sigma_{DW} = \pm K \cdot (0,42 \cdot \sigma_B + 39,3) \cdot \left[0,264 + 1,073 \cdot D_G^{-0,2} + \frac{785 - \sigma_B}{4900} + \frac{196}{\sigma_B} \cdot \sqrt{\frac{1}{R_G}} \right]$$

where:

σ_{DW} = allowable fatigue strength of crankshaft [N/mm²]
 K = factor for different types of crankshafts without surface treatment. Values greater than 1 are only applicable to fatigue strength in fillet area.
 = 1,05 for continuous grain flow forged or drop-forged crankshafts
 = 1,0 for free form forged crankshafts (without continuous grain flow)
 factor for cast steel crankshafts with cold rolling treatment in fillet area
 = 0,93 for cast steel crankshafts manufactured by companies using a classification society approved cold rolling process
 σ_B = minimum tensile strength of crankshaft material [N/mm²]

For other parameters see item [B.3](#).

When a surface treatment process is applied, it must be approved by BKI.

These formulae are subject to the following conditions:

- surfaces of the fillet, the outlet of the oil bore and inside the oil bore (down to a minimum depth equal to 1,5 times the oil bore diameter) shall be smoothly finished.

- for calculation purposes R_H , R_G or R_X are to be taken as not less than 2 mm.

As an alternative the fatigue strength of the crankshaft can be determined by experiment based either on full size crankthrow (or crankshaft) or on specimens taken from a full size crankthrow.

In any case the experimental procedure for fatigue evaluation of specimens and fatigue strength of crankshaft assessment have to be submitted for approval to BKI (method, type of specimens, number of specimens (or crankthrows), number of tests, survival probability, confidence number, etc.).

F. Acceptability Criteria

The sufficient dimensioning of a crankshaft is confirmed by a comparison of the equivalent alternating stress and the fatigue strength. This comparison has to be carried out for the crankpin fillet, the journal fillet, the outlet of crankpin oil bore and is based on the formula:

$$Q = \frac{\sigma_{DW}}{\sigma_v}$$

where:

$$Q = \text{acceptability factor}$$

Adequate dimensioning of the crankshaft is ensured if the smallest of all acceptability factors satisfies the criteria:

$$Q \geq 1,15$$

G. Calculation of Shrink-Fits of Semi-Built Crankshafts

1. General

All crank dimensions necessary for the calculation of the shrink-fit are shown in Fig. 2.6.

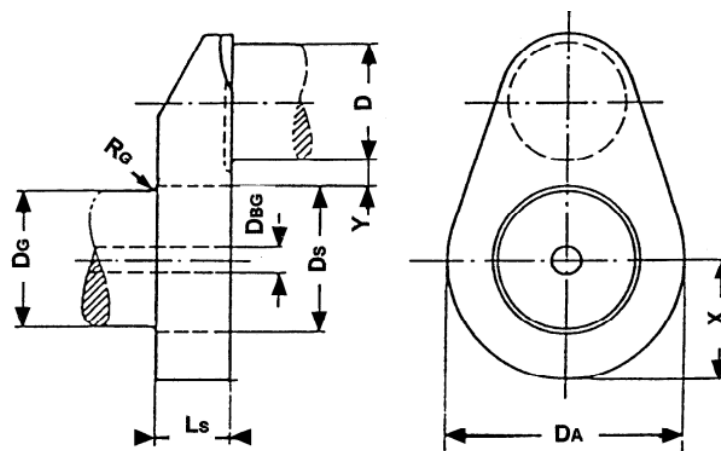

Fig. 2.6 Crankthrow of semi-built crankshaft

where:

$$D_A = \text{outside diameter of web [mm]}$$

or

twice the minimum distance x between centre-line of journals and outer contour of web, whichever is less

- D_S = shrink diameter [mm]
 - D_G = journal diameter [mm]
 - D_{BG} = diameter of axial bore in journal [mm]
 - L_S = length of shrink-fit [mm]
 - R_G = fillet radius of journal [mm]
 - y = distance between the adjacent generating lines of journal and pin [mm]
- $$y \geq 0,05 \cdot D_S$$

Where y is less than $0,1 \cdot D_S$ special consideration is to be given to the effect of the stress due to the shrink-fit on the fatigue strength at the crankpin fillet.

Respecting the radius of the transition from the journal to the shrink diameter, the following should be complied with:

$$R_G \geq 0,015 \cdot D_G$$

and

$$R_G \geq 0,5 \cdot (D_S - D_G)$$

where the greater value is to be considered.

The actual oversize Z of the shrink fit must be within the limits Z_{min} and Z_{max} calculated in accordance with items G.3 and G.4.

In the case where G.2 condition cannot be fulfilled then G.3 and G.4 calculation methods of Z_{min} and Z_{max} are not applicable due to multi zone plasticity problems.

In such case Z_{min} and Z_{max} have to be established based on FEM calculations.

2. Maximum permissible hole in the journal pin

The maximum permissible hole diameter in the journal pin is calculated in accordance with the following formula:

$$D_{BG} = D_S \cdot \sqrt{1 - \frac{4000 \cdot S_R \cdot M_{max}}{\mu \cdot \pi \cdot D_S^2 \cdot L_S \cdot \sigma_{SP}}}$$

where:

- S_R = safety factor against slipping, however a value not less than 2 is to be taken unless documented by experiments.
- M_{max} = absolute maximum value of the torque M_{Tmax} in accordance with B.2.2 [Nm]
- μ = coefficient for static friction, however a value not greater than 0,2 is to be taken unless documented by experiments.
- σ_{SP} = minimum yield strength of material for journal pin [N/mm²]

This condition serves to avoid plasticity in the hole of the journal pin.

3. Necessary minimum oversize of shrink fit

The necessary minimum oversize is determined by the greater value calculated according to:

$$Z_{\min} \geq \frac{\sigma_{sw} \cdot D_s}{E_m}$$

and

$$Z_{\min} \geq \frac{4000 \cdot S_R \cdot M_{\max}}{\mu \cdot \pi \cdot E_m \cdot D_s \cdot L_s} \cdot \frac{1 - Q_A^2 \cdot Q_S^2}{(1 - Q_A^2) \cdot (1 - Q_S^2)}$$

where:

- Z_{\min} = minimum oversize [mm]
- E_m = Young's modulus [N/mm²]
- σ_{sw} = minimum yield strength of material for crank web [N/mm²]
- Q_A = web ratio, $Q_A = \frac{D_s}{D_A}$
- Q_S = shaft ratio, $Q_S = \frac{D_{BG}}{D_s}$

4. Maximum permissible oversize of shrink fit

The maximum permissible oversize is calculated according to:

$$Z_{\max} \leq D_s \cdot \left(\frac{\sigma_{sw}}{E_m} + \frac{0,8}{1000} \right)$$

This condition serves to restrict the shrinkage induced mean stress in the fillet.

This page intentionally left blank

Annex A Definition of stress concentration factor in crankshaft fillets

Stress	Max $\ \sigma_3\ $	Max σ_1	
Location of maximal stresses	A	C	B
Typical principal stress system Mohr's circle diagram with $\sigma_2 = 0$			
Equivalent stress and S.C.F.	$\tau_{\text{equiv}} = \frac{\sigma_1 - \sigma_3}{2}$ $\text{S.C.F.} = \frac{\tau_{\text{equiv}}}{\tau_n} \text{ for } \alpha_T, \beta_T$		
Location of maximal stresses	B	B	B
Typical principal stress system Mohr's circle diagram with $\sigma_3 = 0$			
Equivalent stress and S.C.F.	$\sigma_{\text{equiv}} = \sqrt{\sigma_1^2 + \sigma_2^2 - \sigma_1 \cdot \sigma_2}$ $\text{S.C.F.} = \frac{\sigma_{\text{equiv}}}{\sigma_n} \text{ for } \alpha_B, \beta_B, \beta_Q$		

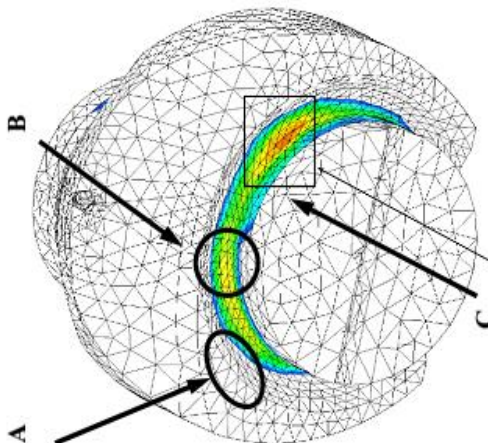

This page intentionally left blank

Annex B Stress concentration factor and stress distribution at the edge of oil drillings

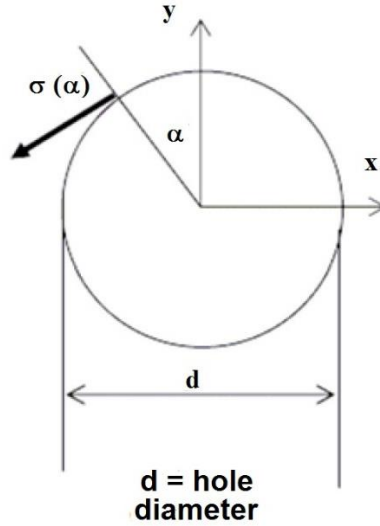

Stress type	Nominal stress tensor	Uniaxial stress distribution around the edge	Mohr's circle diagram
Tension	$\begin{bmatrix} \sigma_n & 0 \\ 0 & 0 \end{bmatrix}$	$\sigma_\alpha = \sigma_n \gamma_B / 3 [1 + 2 \cos(2\alpha)]$	<p>$\gamma_B = \sigma_{\max} / \sigma_n$ for $\alpha = k\pi$</p>
Shear	$\begin{bmatrix} 0 & \tau_n \\ \tau_n & 0 \end{bmatrix}$	$\sigma_\alpha = \gamma_T \tau_n \sin(2\alpha)$	<p>$\gamma_T = \sigma_{\max} / \tau_n$ for $\alpha = \frac{\pi}{4} + k \frac{\pi}{2}$</p>
Tension + shear	$\begin{bmatrix} \sigma_n & \tau_n \\ \tau_n & 0 \end{bmatrix}$	$\sigma_\alpha = \frac{\gamma_B}{3} \sigma_n \left\{ 1 + 2 \left[\cos(2\alpha) + \frac{3}{2} \frac{\gamma_T \tau_n}{\gamma_B \sigma_n} \sin(2\alpha) \right] \right\}$	<p>$\sigma_{\max} = \frac{\gamma_B}{3} \sigma_n \left[1 + 2 \sqrt{1 + \frac{9}{4} \left(\frac{\gamma_T \tau_n}{\gamma_B \sigma_n} \right)^2} \right]$</p> <p>for $\alpha = \frac{1}{2} \text{tg}^{-1} \left(\frac{3\gamma_T \tau_n}{2\gamma_B \sigma_n} \right)$</p>

This page intentionally left blank

Annex C Alternative method for calculation of stress concentration factors in the web fillet radii of crankshafts by utilizing Finite Element Method

A.	General	C-1
B.	Model requirements.....	C-1
C.	Load cases.....	C-3

A. General

The objective of the analysis is to develop Finite Element Method (FEM) calculated figures as an alternative to the analytically calculated Stress Concentration Factors (SCF) at the crankshaft fillets. The analytical method is based on empirical formulae developed from strain gauge measurements of various crank geometries and accordingly the application of these formulae is limited to those geometries.

The SCF's calculated according to the rules of this Guidance are defined as the ratio of stresses calculated by FEM to nominal stresses in both journal and pin fillets. When used in connection with the present method in this Guidance or the alternative methods, Von Mises stresses shall be calculated for bending and principal stresses for torsion.

The procedure as well as evaluation guidelines are valid for both solid cranks and semibuilt cranks (except journal fillets).

The analysis is to be conducted as linear elastic FE analysis, and unit loads of appropriate magnitude are to be applied for all load cases.

The calculation of SCF at the oil bores is not covered by this document.

It is advised to check the element accuracy of the FE solver in use, e.g. by modeling a simple geometry and comparing the stresses obtained by FEM with the analytical solution for pure bending and torsion.

Boundary Element Method (BEM) may be used instead of FEM.

B. Model requirements

The basic recommendations and perceptions for building the FE-model are presented in 1. It is obligatory for the final FE-model to fulfill the requirement in 3.

1. Element mesh recommendations

In order to fulfil the mesh quality criteria it is advised to construct the FE model for the evaluation of Stress Concentration Factors according to the following recommendations:

- The model consists of one complete crank, from the main bearing centerline to the opposite side main bearing centerline
- Element types used in the vicinity of the fillets:
 - 10 node tetrahedral elements
 - 8 node hexahedral elements
 - 20 node hexahedral elements

Annex C Alternative method for calculation of stress concentration factors in the web fillet radii of crankshafts by utilizing Finite Element Method

B

- Mesh properties in fillet radii. The following applies to ± 90 degrees in circumferential direction from the crank plane:
 - Maximum element size $a = r/4$ through the entire fillet as well as in the circumferential direction. When using 20 node hexahedral elements, the element size in the circumferential direction may be extended up to $5a$. In the case of multi-radii fillet r is the local fillet radius. (If 8 node hexahedral elements are used even smaller element size is required to meet the quality criteria.)
 - Recommended manner for element size in fillet depth direction
 - First layer thickness equal to element size of a
 - Second layer thickness equal to element to size of $2a$
 - Third layer thickness equal to element to size of $3a$
 - Minimum 6 elements across web thickness
 - Generally the rest of the crank should be suitable for numeric stability of the solver.
 - Counterweights only have to be modeled only when influencing the global stiffness of the crank significantly.
 - Modeling of oil drillings is not necessary as long as the influence on global stiffness is negligible and the proximity to the fillet is more than $2r$, see Fig. C.1.
 - Drillings and holes for weight reduction have to be modeled.
 - Sub-modeling may be used as far as the software requirements are fulfilled.

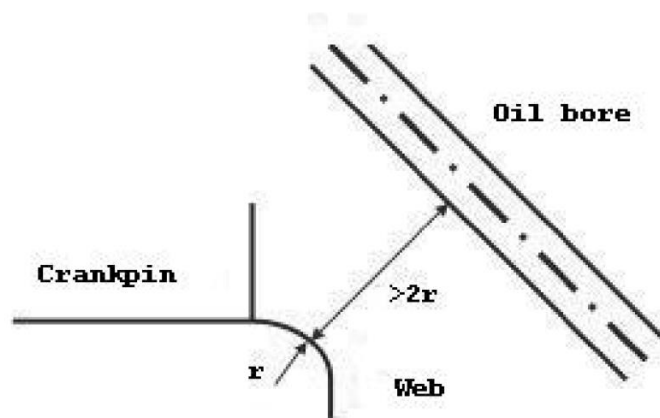

Fig. C.1. Oil bore proximity to fillet.

2. Material

This Guidance does not consider material properties such as Young's Modulus (E) and Poisson's ratio (ν). In FE analysis those material parameters are required, as strain is primarily calculated and stress is derived from strain using the Young's Modulus and Poisson's ratio. Reliable values for material parameters have to be used, either as quoted in literature or as measured on representative material samples.

For steel the following is advised:

$$E = 2,05 \cdot 10^5 \text{ Mpa} \quad \text{and}$$

$$\nu = 0,3$$

3. Element mesh quality criteria

If the actual element mesh does not fulfil any of the following criteria at the examined area for SCF evaluation, then a second calculation with a refined mesh is to be performed.

3.1 Principal stresses criterion

The quality of the mesh should be assured by checking the stress component normal to the surface of the fillet radius. Ideally, this stress should be zero. With principal stresses σ_1 , σ_2 and σ_3 the following criterion is required:

$$\min (|\sigma_1|, |\sigma_2|, |\sigma_3|) < 0,03 \cdot \max (|\sigma_1|, |\sigma_2|, |\sigma_3|)$$

3.2 Averaged/unaveraged stresses criterion

The criterion is based on observing the discontinuity of stress results over elements at the fillet for the calculation of SCF:

Unaveraged nodal stress results calculated from each element connected to a node, should differ less than by 5 % from the 100 % averaged nodal stress results at this node at the examined location.

C. Load cases

To substitute the analytically determined SCF in this Guidance, the following load cases have to be calculated.

1. Torsion

In analogy to the testing apparatus used for the investigations made by FVV the structure is loaded pure torsion. In the model surface warp at the end faces is suppressed.

Torque is applied to the central node located at the crankshaft axis. This node acts as the master node with 6 degrees of freedom and is connected rigidly to all nodes of the end face.

Boundary and load conditions are valid for both in-line and V-type engines.

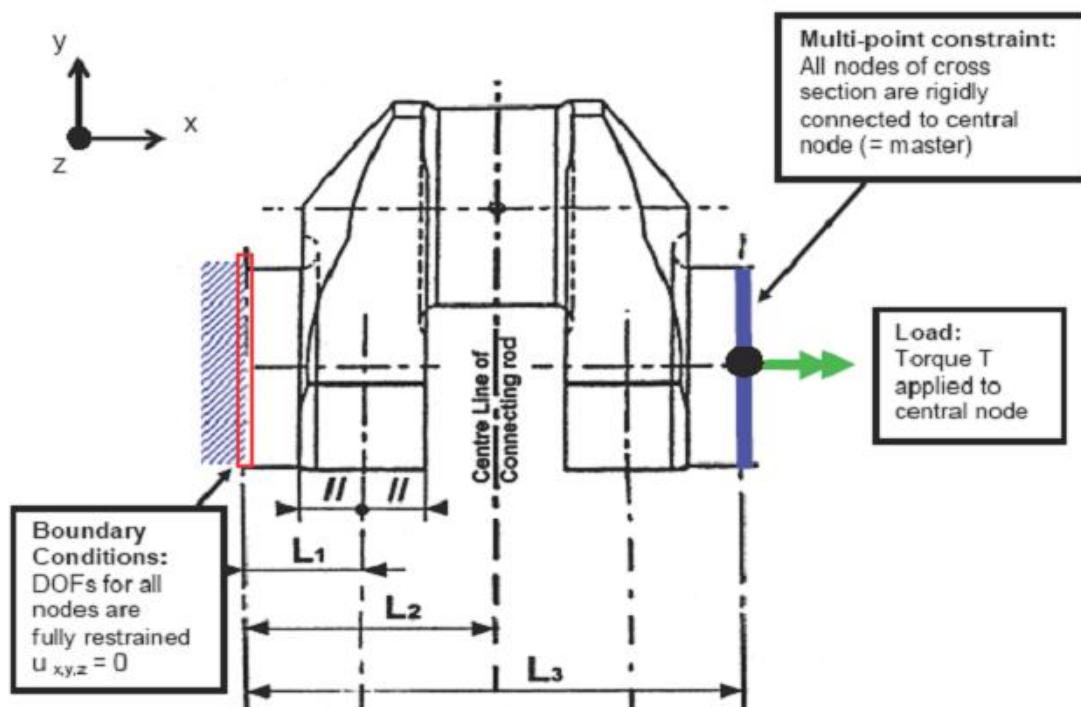

Fig. C.2 Boundary and load conditions for the torsion load case.

Annex C Alternative method for calculation of stress concentration factors in the web fillet radii of crankshafts by utilizing Finite Element Method

C

For all nodes in both the journal and crank pin fillet principal stresses are extracted and the equivalent torsional stress is calculated:

$$\tau_{\text{equiv}} = \max\left(\left|\frac{\sigma_1 - \sigma_2}{2}\right|, \left|\frac{\sigma_2 - \sigma_3}{2}\right|, \left|\frac{\sigma_1 - \sigma_3}{2}\right|\right)$$

The maximum value taken for the subsequent calculation of the SCF:

$$\alpha_T = \frac{\tau_{\text{equiv}\alpha}}{\tau_N}$$

$$\beta_T = \frac{\tau_{\text{equiv}\beta}}{\tau_N}$$

where τ_N is nominal torsional stress referred to the crankpin and respectively journal as per B.2 with the torsional torque T:

$$\tau_N = \frac{T}{W_p}$$

2. Pure bending (4 point bending)

In analogy to the testing apparatus used for the investigations made by FVV the structure is loaded in pure bending. In the model surface warp at the end faces is suppressed.

The bending moment is applied to the central node located at the crankshaft axis. This node acts as the master node with 6 degrees of freedom and is connected rigidly to all nodes of the end face.

Boundary and load conditions are valid for both in-line and V-type engines.

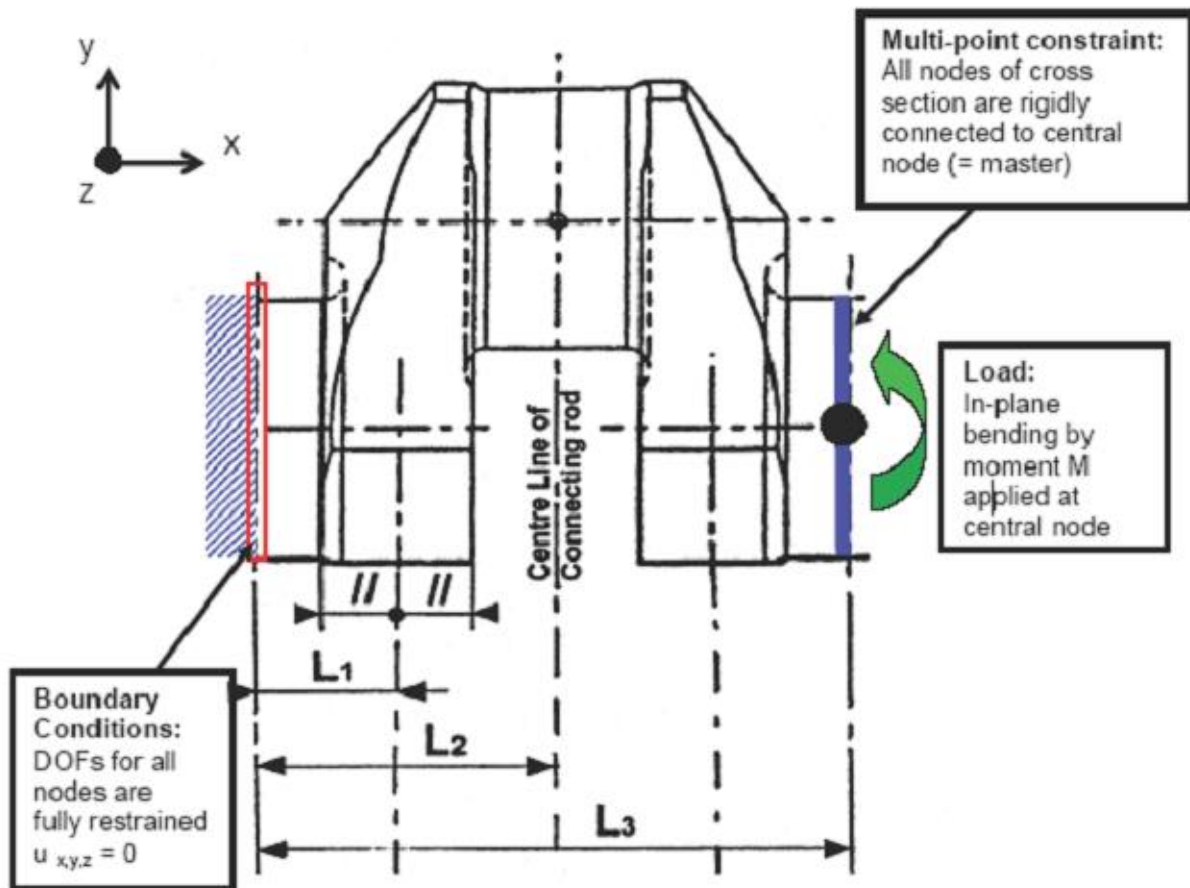

Fig. C.3 Boundary and load conditions for the pure bending load case.

For all nodes in both the journal and pin fillet von Mises equivalent stresses σ_{equiv} are extracted. The maximum value is used to calculate the SCF according to:

$$\alpha_B = \frac{\sigma_{equiv\alpha}}{\sigma_N}$$

$$\beta_B = \frac{\sigma_{equiv\beta}}{\sigma_N}$$

Nominal stress σ_N is calculated as per Section 2, A.1.2.1 with the bending moment M:

$$\sigma_N = \frac{M}{W_{eqw}}$$

3. Bending with shear force (3-point bending)

This load case is calculated to determine the SCF for pure transverse force (radial force, β_{α}) for the journal fillet.

In analogy to the testing apparatus used for the investigations made by FVV, the structure is loaded in 3-point bending. In the model, surface warp at the both end faces is suppressed. All nodes are connected rigidly to the centre node; boundary conditions are applied to the centre nodes. These nodes act as master nodes with 6 degrees of freedom.

Annex C Alternative method for calculation of stress concentration factors in the web fillet radii of crankshafts by utilizing Finite Element Method

C

The force is applied to the central node located at the pin centre-line of the connecting rod. This node is connected to all nodes of the pin cross sectional area. Warping of the sectional area is not suppressed.

Boundary and load conditions are valid for in-line and V-type engines. V-type engines can be modeled with one connecting rod force only. Using two connecting rod forces will make no significant change in the SCF.

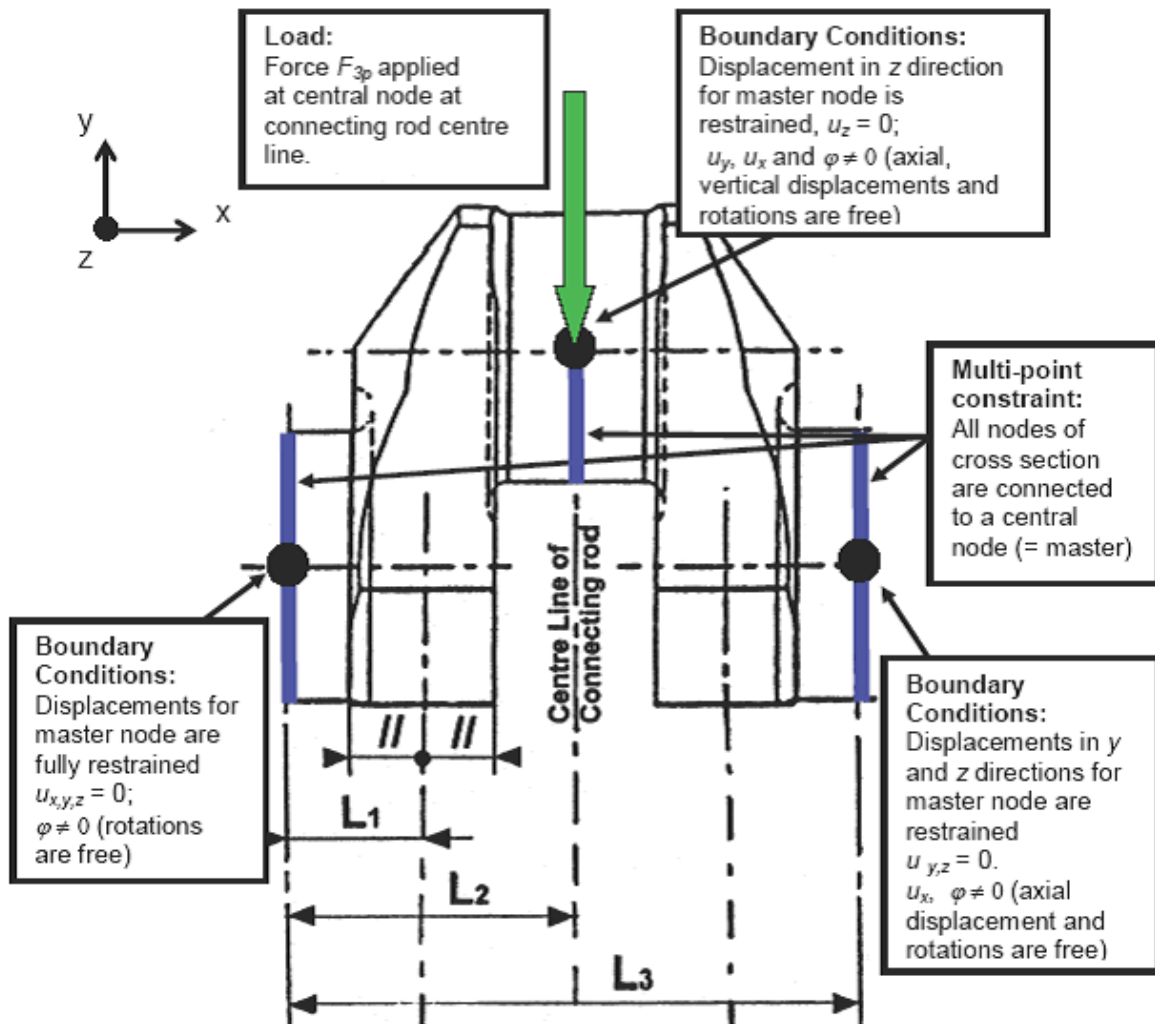

Fig. C.4. Boundary and load conditions for the 3-point bending load case of an inline engine.

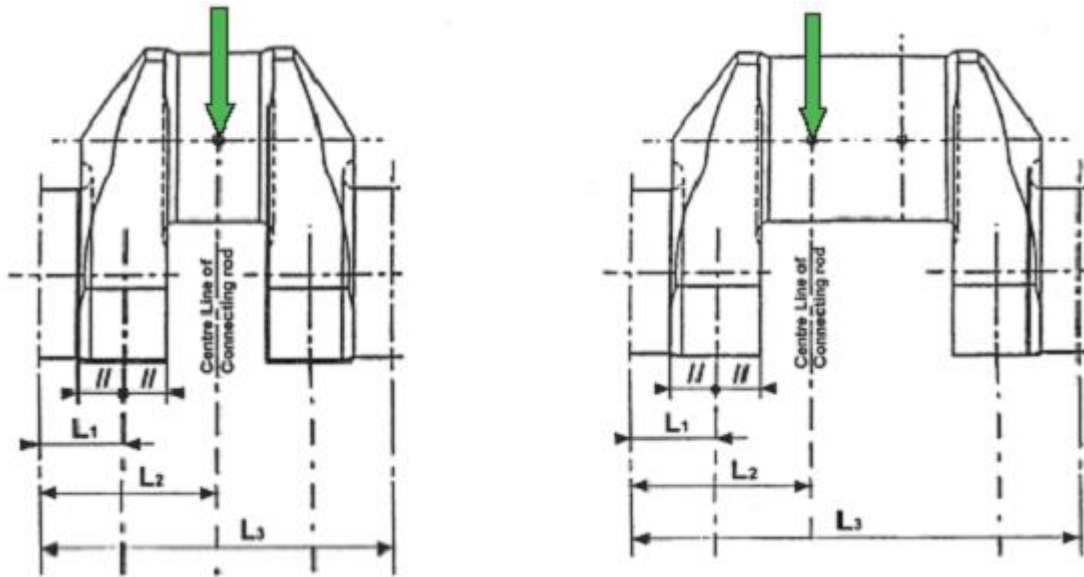

Fig. C.5 Load applications for in-line and V-type engines.

The maximum equivalent von Mises stress σ_{3P} in the journal fillet is evaluated. The SCF in the journal fillet can be determined in two ways as shown below.

3.1 Method 1

This method is analogue to the FVV investigation. The results from 3-point and 4-point bending are combined as follows:

$$\sigma_{3P} = \sigma_{N3P} \cdot \beta_B + \sigma_{Q3P} \cdot \beta_Q$$

where:

- σ_{3P} = as found by the FE calculation.
- σ_{N3P} = Nominal bending stress in the web centre due to the force F_{3P} [N] applied to the centre line of the actual connecting rod, see Fig. C.5.
- β_B = as determined in paragraph 3.2.
- σ_{Q3P} = $(Q_{3P}) / (B \cdot W)$ where Q_{3P} is the radial (shear) force in the web due to the force F_{3P} [N] applied to the centre line of the actual connecting rod, see also Fig. C.3 and Fig. C.4 in Guidance.

3.2 Method 2

This method is not analogous to the FVV investigation. In a statically determined system with one crank throw supported by two bearings, the bending moment and radial (shear) force are proportional. Therefore the journal fillet SCF can be found directly by the 3-point bending FE calculation.

The SCF is then calculated according to

$$\beta_{BQ} = \frac{\sigma_{3P}}{\sigma_{N3P}}$$

For symbols see C.3.1.

Annex C Alternative method for calculation of stress concentration factors in the web fillet radii of crankshafts by utilizing Finite Element Method

C

When using this method, the radial force and stress determination in Guidance becomes superfluous. The alternating bending stress in the journal fillet as per [Section 2, A.1.3](#) is then evaluated:

$$\sigma_{BG} = \pm \beta_{BQ} \cdot \sigma_{BFN}$$

Note that the use of this method does not apply to the crankpin fillet and that this SCF must not be used in connection with calculation methods other than those assuming a statically determined system as in Guidance.