



Guidelines for Classification and Construction  
**Part 1 Seagoing Ships**

# **GUIDELINES FOR THE USE OF GAS OR OTHER LOW-FLASHPOINT FUELS FOR SHIPS**

**Volume 1**

July 2024 Edition





Guidelines for Classification and Construction  
**Part 1 Seagoing Ships**

# **GUIDELINES FOR THE USE OF GAS OR OTHER LOW-FLASHPOINT FUELS FOR SHIPS**

**Volume 1**

July 2024 Edition





**Amendments to the preceding Edition are marked by red colour and expanded text. However, if the changes involves the whole section or sub section normally only the title will be in red colour.**

Reproduction in whole or in part by any means of these Guidance, is subject to the permission in writing by Biro Klasifikasi Indonesia Head Office.

## Foreword

This [Guidelines for the Use of Gas or other Low-Flashpoint Fuels for Ships \(Pt.1, Vol.1\) July 2024 edition](#) replace the [Guidelines for the Use of Gas or other Low-Flashpoint Fuels for Ships \(Pt.1, Vol.1\) 2024 edition](#). In this edition, new amendments are introduced which are mainly derived from IACS publications, and inputs from BKI Branch Offices and Technical Division BKI Head Office.

The summary of previous edition and amendments including the implementation date are indicated in Table below:

	<b>Edition/ Guidelines Change Notice (RCN)</b>	<b>Effective Date</b>	<b>Link</b>
1	Edition 2024	1 <sup>st</sup> January 2024	
2	Edition 2022	1 <sup>st</sup> July 2022	
3	GCN No.1 November 2021	1 <sup>st</sup> July 2022	
4	Edition 2015	1 <sup>st</sup> October 2015	

**Note:**

- Full previous edition and amendments including its amendment notice is available through the link above
- Generally, the effective date of Guidelines/GCN is given in the table above. However, several requirements within the amendment may be differently specified, see its amendment notice for detail

This Guidelines is available to be downloaded at [www.bki.co.id](http://www.bki.co.id). Once downloaded, this Guidelines will be uncontrolled copy. Please check the latest version on the website.

Further queries or comments concerning this Guidelines are welcomed through communication to BKI Head Office.

*This page intentionally left blank*

## Guidelines Amendment Notice

These pages contain amendments within the following sections of the Guidelines for the Use of Gas or other Low-Flashpoint Fuels for Ships (Pt.1, Vol.1) July 2024 edition

These amendments will come into force on 1<sup>st</sup> July 2024 unless specified otherwise in the table.

Paragraph	Title/Subject	Status/Remark
<b>Section 7 Material and General Pipe Design</b>		
Table 7.3	Plates, Sections and Forgings for Fuel Tanks, Secondary Barriers and Process Pressure Vessels for Design Temperatures Below Minus 55°C and Down to Minus 165°C. Maximum thickness 25 mm	Corrigenda
<b>Section 9 Fuel Supply to Consumers</b>		
9.2.2	-	To add an interpretation according to IACS UI GF19

*This page intentionally left blank*



# Table of Contents

<b>Foreword</b> .....	<b>iii</b>
<b>Guidelines Amendment Notice</b> .....	<b>v</b>
<b>Table of Contents</b> .....	<b>vii</b>
<b>Section 1 Application, Classification, Notation and Surveys</b> .....	<b>1-1</b>
1.1 Application .....	1-1
1.2 Classification and Notation .....	1-2
1.3 Classification Survey during Construction .....	1-2
1.4 Periodical Surveys .....	1-5
<b>Section 2 General</b> .....	<b>2-1</b>
2.1 Application .....	2-1
2.2 Definitions .....	2-1
2.3 Alternative Design .....	2-4
<b>Section 3 Goal and Functional Requirements</b> .....	<b>3-1</b>
3.1 Goal .....	3-1
3.2 Functional requirements .....	3-1
<b>Section 4 General Requirements</b> .....	<b>4-1</b>
4.1 Goal .....	4-1
4.2 Risk assessment .....	4-1
4.3 Limitation of explosion consequences .....	4-1
<b>Section 5 Ship Design and Arrangement</b> .....	<b>5-1</b>
5.1 Goal .....	5-1
5.2 Functional requirements .....	5-1
5.3 General requirements .....	5-1
5.4 Machinery space concepts .....	5-4
5.5 Gas safe machinery space .....	5-4
5.6 ESD-protected machinery spaces .....	5-4
5.7 Location and protection of fuel piping .....	5-5
5.8 Fuel preparation room design .....	5-5
5.9 Bilge systems .....	5-5
5.10 Requirements for drip trays .....	5-6
5.11 Requirements for arrangement of entrances and other openings in enclosed spaces .....	5-6
5.12 Requirements for Airlocks .....	5-6
<b>Section 6 Ship Design and Arrangement</b> .....	<b>6-1</b>
6.1 Goal .....	6-1
6.2 Functional requirements .....	6-1
6.3 General Requirements .....	6-2

6.4	Liquefied gas fuel containment . . . . .	6-2
6.5	Portable liquefied gas fuel tanks . . . . .	6-28
6.6	CNG fuel containment . . . . .	6-29
6.7	Pressure relief system . . . . .	6-29
6.8	Loading limit for liquefied gas fuel tanks . . . . .	6-33
6.9	Maintaining of fuel storage condition . . . . .	6-34
6.10	Atmospheric control within the fuel containment system . . . . .	6-35
6.11	Atmosphere control within fuel storage hold spaces (Fuel containment systems other than type C independent tanks) . . . . .	6-35
6.12	Environmental control of spaces surrounding type C independent tanks . . . . .	6-36
6.13	Requirement on inerting . . . . .	6-36
6.14	Inert gas production and storage on board . . . . .	6-36
<b>Section 7</b>	<b>Material and General Pipe Design . . . . .</b>	<b>7-1</b>
7.1	Goal . . . . .	7-1
7.2	Functional requirements . . . . .	7-1
7.3	General pipe design . . . . .	7-1
7.4	Requirements for materials . . . . .	7-4
<b>Section 8</b>	<b>Bunkering . . . . .</b>	<b>8-1</b>
8.1	Goal . . . . .	8-1
8.2	Functional requirements . . . . .	8-1
8.3	Bunkering station . . . . .	8-1
8.4	Requirements for manifold . . . . .	8-2
8.5	Bunkering system . . . . .	8-2
<b>Section 9</b>	<b>Fuel Supply to Consumers . . . . .</b>	<b>9-1</b>
9.1	Goal . . . . .	9-1
9.2	Functional requirements . . . . .	9-1
9.3	Redundancy of fuel supply . . . . .	9-1
9.4	Safety functions of gas supply system . . . . .	9-2
9.5	Fuel distribution outside of machinery space . . . . .	9-2
9.6	Fuel supply to consumers in gas-safe machinery spaces . . . . .	9-3
9.7	Gas fuel supply to consumers in ESD-protected machinery spaces . . . . .	9-3
9.8	Design of ventilated duct, outer pipe against inner pipe gas leakage . . . . .	9-4
9.9	Gas compressors and pumps . . . . .	9-4
<b>Section 10</b>	<b>Power Generation Including Propulsion and Other Gas Consumer . . . . .</b>	<b>10-1</b>
10.1	Goal . . . . .	10-1
10.2	Functional requirements . . . . .	10-1
10.3	Internal combustion engines of Piston type . . . . .	10-1
10.4	Main and auxiliary boilers . . . . .	10-2
10.5	Gas turbines . . . . .	10-3
<b>Section 11</b>	<b>Fire Safety . . . . .</b>	<b>11-1</b>
11.1	Goal . . . . .	11-1
11.2	Functional requirements . . . . .	11-1
11.3	Fire protection . . . . .	11-1
11.4	Fire main . . . . .	11-2
11.5	Water spray system . . . . .	11-2
11.6	Dry chemical powder fire-extinguishing system . . . . .	11-3
11.7	Fire detection and alarm system . . . . .	11-3
11.8	Fuel preparation room fire-extinguishing systems . . . . .	11-3

---

<b>Section 12</b>	<b>Explosion Prevention</b>	<b>12-1</b>
12.1	Goal	12-1
12.2	Functional requirements	12-1
12.3	General	12-1
12.4	Area classification	12-1
12.5	Hazardous area zones	12-2
<b>Section 13</b>	<b>Ventilation</b>	<b>13-1</b>
13.1	Goal	13-1
13.2	Functional requirements	13-1
13.3	General	13-1
13.4	Tank connection space	13-2
13.5	Requirements for machinery spaces	13-3
13.6	Requirements for fuel preparation room	13-3
13.7	Requirements for bunkering station	13-3
13.8	Requirements for ducts and double pipes	13-3
<b>Section 14</b>	<b>Electrical Installations</b>	<b>14-1</b>
14.1	Goal	14-1
14.2	Functional requirements	14-1
14.3	General	14-1
<b>Section 15</b>	<b>Control, Monitoring and Safety Systems</b>	<b>15-1</b>
15.1	Goal	15-1
15.2	Functional requirements	15-1
15.3	General	15-1
15.4	Bunkering and liquefied gas fuel tank monitoring	15-2
15.5	Bunkering control	15-3
15.6	Gas compressor monitoring	15-3
15.7	Gas engine monitoring	15-3
15.8	Gas detection	15-4
15.9	Fire detection	15-5
15.10	Ventilation	15-7
15.11	Safety functions of fuel supply systems	15-7
<b>Section 16</b>	<b>Manufacture, Workmanship and Testing</b>	<b>16-1</b>
16.1	General	16-1
16.2	General test regulations and specifications	16-1
16.3	Welding of metallic materials and non-destructive testing for the fuel containment system	16-3
16.4	Other regulations for construction in metallic materials	16-6
16.5	Testing	16-6
16.6	Welding, post-weld heat treatment and non-destructive testing	16-8
16.7	Testing requirements	16-9
<b>Section 17</b>	<b>Drills and Emergency Exercises</b>	<b>17-1</b>
17.1	Drills and Emergency Exercises	17-1
<b>Section 18</b>	<b>Operation</b>	<b>18-1</b>
18.1	General	18-1
18.2	Functional requirements	18-1
18.3	Maintenance	18-1
18.4	Bunkering operations	18-2
18.5	Enclosed space entry	18-3

---

18.6	Inerting and purging of fuel systems . . . . .	18-3
18.7	Hot work on or near fuel systems . . . . .	18-4
<b>Section 19</b>	<b>Training . . . . .</b>	<b>19-1</b>
19.1	General . . . . .	19-1
19.2	Functional requirements . . . . .	19-1
<b>Annex A</b>	<b>Standard for the Use of Limit State Methodologies in The Design of Fuel Containment Systems of Novel Configuration . . . . .</b>	<b>A-1</b>
A.1	General . . . . .	A-1
A.2	Design Format . . . . .	A-1
A.3	Required Analyses . . . . .	A-2
A.4	Ultimate Limit States . . . . .	A-3
A.5	Fatigue Limit States . . . . .	A-6
A.6	Accident Limit States . . . . .	A-7
A.7	Testing . . . . .	A-7
<b>Annex B</b>	<b>LNG Bunker Delivery Note . . . . .</b>	<b>B-1</b>

# Section 1 Application, Classification, Notation and Surveys

1.1	Application . . . . .	1-1
1.2	Classification and Notation . . . . .	1-2
1.3	Classification Survey during Construction . . . . .	1-2
1.4	Periodical Surveys . . . . .	1-5

## 1.1 Application

**1.1.1** These guidelines incorporate the IGF-Code in the course of the development in IMO and provide provisions for the arrangements, installations, surveys, control and monitoring of machinery, equipment and systems using natural gas or other low-flashpoint fuels to minimize the risk to the ship, its crew and the environment, having regard to the nature of the fuels involved.

**1.1.2** Due to the rapidly evolving new fuels technology, BKI will periodically review these guidelines, taking into account both experience and technical developments.

**1.1.3** Differing from the standard construction of the Guidelines, which is given in this [Section 1](#), [Section 2](#) - [Section 19](#) for direct comparison with the IGF-Code (International Code of Safety for Ships using Gases or other Low-flashpoint Fuels) are arranged accordingly with addition and alteration as necessary.

In the following Sections ([Section 2](#) to [Section 19](#)), specific requirements of BKI which are added to the provision of the IGF-Code have been marked by a special paragraph number (e.g. C2.3) and highlighted.

For interpretation of IGF-Code, the [Guidance for Code and Convention Interpretation \(Pt.1, Vol.Y\)](#), [Section 5](#) is to be observed.

**1.1.4** Special for [Section 5](#) to [Section 18](#), fuel in the context of those Sections means natural gas, either in its liquefied or gaseous state.

It should be recognized that the composition of natural gas may vary depending on the source of natural gas and the processing of the gas.

For other low-flashpoint fuels, compliance with the functional requirements of this Guidelines must be demonstrated through alternative design.

### 1.1.5 Rules for Classification and Construction

In addition to the following Rules for Classification and Construction shall be observed:

- [Rules for Hull \(Pt.1, Vol.II\)](#),
- [Rules for Machinery Installations \(Pt.1, Vol.III\)](#),
- [Rules for Electrical Installations \(Pt.1, Vol.IV\)](#),
- [Rules for Automation \(Pt.1, Vol.VII\)](#).

## 1.2 Classification and Notation

**1.2.1** The classification and surveys of ships intended to be classed with BKI or classed with BKI are to be in accordance with the requirements specified in the following subsection. For admission to class, survey during construction specified 1.3 used for new building and for conversion or modification of existing ship.

**1.2.2** The additional notation **LFF** will be assigned to the natural gas or other low-flashpoint fuelled ships where the requirements for gas fuel storage, fuel bunkering systems, fuel gas preparation rooms and fuel gas supply system arrangements are to be designed, constructed and tested in accordance with these Guidelines.

**1.2.3** The **LFF** notation will be assigned to machinery installation in association with the following qualifiers (e.g., **LFF (DF-CNG)**):

- **DF-LNG**, where a dual fuel diesel engine or turbine power plant, for propulsion or auxiliary purposes, is designed, constructed and tested using LNG as fuel in accordance with these Guidelines.
- **SF-LNG**, where a single gas fuel diesel engine or turbine power plant, for propulsion or auxiliary purposes, is designed, constructed and tested using LNG as fuel in accordance with these Guidelines.
- **DF-CNG**, where a dual fuel diesel engine or turbine power plant, for propulsion or auxiliary purposes, is designed, constructed and tested using CNG as fuel in accordance with these Guidelines.
- **SF-CNG**, where a single fuel diesel engine or turbine power plant, for propulsion or auxiliary purposes, is designed, constructed and tested using CNG as fuel in accordance with these Guidelines.

For a details explanation about above additional class notations, see [Guidance for Class Notations \(Pt.0, Vol.B\) Sec.3, B.1.](#)

### 1.2.4 Maintenance of Classification

**.1** Ships classed with BKI are to be subjected to the surveys to maintain the classification and are to be maintained in good condition in accordance with the requirements specified in this Section.

**.2** Plans and particulars of any proposed alterations to the approved scantlings or arrangements of hull, machinery or equipment are to be submitted for approval by the BKI before the work is commenced and such alterations are to be Surveyed by BKI.

## 1.3 Classification Survey during Construction

### 1.3.1 General

At the Classification Survey during Construction, the hull, machinery and equipment are to be examined in detail in order to ascertain that they meet the relevant requirements of this Guidelines.

### 1.3.2 Plan and Documents

For a ship in which natural gas-fuelled engine installations are installed, plans and documents in form of electronic format, specified in 1.3.3 and 1.3.4, are to be submitted and approved before the work is commenced. And, BKI, where considered necessary, may require further plans and documents other than those specified below.

### 1.3.3 Plan and data for approval

- 1) Arrangement plans showing location of:
  - A) Machinery spaces, accommodation, service and control station spaces
  - B) Fuel containment systems
  - C) Fuel preparation rooms
  - D) Fuel bunkering pipes with shore connections
  - E) Tank hatches, ventilation pipes and any other openings to the gas tanks
  - F) Ventilating pipes, doors and openings to fuel preparation rooms and other hazardous areas
  - G) Entrances, air inlets and openings to accommodation, service and control station spaces
  - H) Hazardous areas of zone "0", "1" and "2"
- 2) Following plans and data of the fuel containment system:
  - A) Drawing of gas tanks including information on non-destructive testing of welds and strength and tightness testing of tanks
  - B) Drawings of support and staying of gas tanks
  - C) Specification of materials in gas tanks and gas piping systems
  - D) Specifications of welding procedures for gas tanks
  - E) Specification of stress relieving procedures for independent tanks type C (thermal or mechanical)
  - F) Specification of design loads and structural analysis of gas tanks
  - G) A complete stress analysis for gas tanks
  - H) Specification of cooling-down procedure for gas tanks
    - I) Arrangement and specifications of second barriers
    - J) Drawings and specifications of gas tank insulation
    - K) Drawing of marking plate for gas tanks
- 3) Following plans and data of piping systems:
  - A) Drawings and specifications of gas piping including ventilation lines of safety relief valves or similar piping
  - B) Drawings and specifications of offsets, loops, bends and mechanical expansion joints, such as bellows, slip joints (only inside tank) or similar means in the gas piping
  - C) Drawings and specifications of flanges, valves and other fittings in the gas piping system. For valves intended for piping systems with a design temperature below - 55 °C, documentation for leak test and functional test at design temperature (type test) is required
  - D) Complete stress analysis of piping system when design temperature is below - 110 °C
  - E) Documentation of type tests for expansion components in the gas piping system.
  - F) Specification of materials, welding, post-weld heat treatment and non-destructive testing of gas piping
  - G) Specification of pressure tests (structural and tightness tests) of gas piping
  - H) Program for functional tests of all piping systems including valves, fittings and associated equipment for handling gas (liquid or vapour)
  - I) Drawings and specifications of insulation for low temperature piping where such insulation is installed
  - J) Specification of electrical bonding of piping

- K) Specification of means for removal of liquid contents from bunkering pipes prior to disconnecting the shore connection
  - L) Cooling or heating water system in connection with gas fuel system, if fitted.
- 4) Following plans and particulars for the safety relief valves:
- A) Drawings and specifications for safety relief valves and pressure/vacuum relief valves and associated ventilation piping
  - B) Calculation of required gas tank relief valve capacity, including back pressure
  - C) Specification of procedures for changing of set pressures of cargo tank safety relief valves if such arrangements are contemplated
  - D) Calculations for safety valves ventilation mast: location, height, details
- 5) Following plans and data for equipment and systems regarding fire protection:
- A) Arrangement and specification of water spray system, including pipes, valves, nozzles and fittings
  - B) Arrangement of ventilation duct required for gas pipes lead through enclosed spaces
  - C) Arrangement of ventilation duct for storage tank fitted below deck, if applicable
  - D) Arrangement of fire detection system for storage tank and ventilation trunk
  - E) Arrangement of fire insulation for storage tank and pipes, ventilation trunks for storage tank connection space
  - F) Arrangement and specification of dry chemical powder installation.
- 6) Following plans and data for electrical installations:
- A) Drawings showing location of all electrical equipment in hazardous areas
  - B) Data for verification of the compatibility between the barrier and the field component
  - C) Single line diagram for intrinsically safe circuits
  - D) List of explosion protected equipment
- 7) Following control and monitoring systems:
- A) Gas detection system
  - B) Gas tank monitoring system
  - C) Gas compressors control and monitoring system
  - D) Gas engines control and monitoring system.
- 8) A test program for the safety functions of the gas installation (may be included in programme for sea trials or on-board test)

#### 1.3.4 Plans and documents for reference

- 1) Plans and data of the following equipment and systems
- A) Drawings showing location and construction of air locks with alarm equipment, if fitted
  - B) Drawings of gastight bulkhead penetrations, if fitted
  - C) Arrangements and specifications of mechanical ventilation systems in spaces covering gas fuel system, giving capacity and location of fans and their motors. Drawings and material specifications of rotating parts and casings for fans and portable ventilators
  - D) Drawings and specifications of protection of hull steel beneath liquid piping where liquid leakage may be anticipated, such as at shore connections and at pump seals



- E) Arrangement and specifications of piping systems for gas freeing and purging of gas tanks
  - F) For fixed gas detection and alarm systems: specification and location of detectors, alarm devices and call points, and cable routing layout drawing
  - G) Bilge and drainage arrangements in gas pump rooms, compressor rooms, tank connection space
  - H) Exhaust gas system.
- 2) Calculation sheets of filling limits for fuel tanks.
  - 3) Operation manual (including bunkering, gas freeing, normal operation, emergency operation).
  - 4) Data for a risk analysis according to Section 4.2).

## **1.4 Periodical Surveys**

### **1.4.1 Annual Survey**

The following is to be carried out during the survey of the Fuel Storage, Fuel Bunkering System and Fuel Supply System.

#### **.1 Logbooks/Records**

The logbooks and operating records are to be examined with regard to correct functioning of the gas detection systems, fuel supply/gas systems, etc. The hours per day of the re-liquefaction plant, gas combustion unit, as applicable, the boil-off rate, and nitrogen consumption (for membrane containment systems) are to be considered together with gas detection records.

#### **.2 Operating and Maintenance Instruction Manuals**

The manufacturer/builder instructions and manuals covering the operations, safety and maintenance requirements and occupational health hazards relevant to fuel storage, fuel bunkering, and fuel supply and associated systems for the use of the fuel, are to be confirmed as being aboard the vessel.

#### **.3 Control, Monitoring and Safety Systems**

**.3.1** Gas detection and other leakage detection equipment in compartments containing fuel storage, fuel bunkering, and fuel supply equipment or components or associated systems, including indicators and alarms, is to be confirmed in satisfactory operating condition. Recalibration of the gas detection systems should be verified in accordance with the manufacturers' recommendations.

**.3.2** Verification of the satisfactory operation of the control, monitoring and automatic shutdown systems as far as practicable of the fuel supply and bunkering systems.

**.3.3** Operational test, as far as practicable, of the shutdown of ESD protected machinery spaces. As a minimum, the operational test is include the following.

- 1) Gas detectors and fire detectors
- 2) Function of ventilation system
- 3) Safety functions in connection with the ventilation systems in machinery space
- 4) Function of ventilation system

## **.4 Fuel Handling Piping, Machinery and Equipment**

### **.4.1 Fuel handling piping**

- 1) Pippings, hoses, double wall piping or duct are to be external examined without dismantling of insulation as far as practicable. Removal of insulation for examination may be required if deemed necessary by the attending Surveyor.
- 2) Emergency shut-down valves and remote operating valves are to be external examined and function-tested.
- 3) Relief valves of fuel piping are to be external examined.
- 4) Disconnection of all electrical equipment or installations not of a certified safe type.

### **.4.2 Machinery and Equipment**

- 1) Machinery and equipment for fuel storage, fuel bunkering, and fuel supply such as venting, compressing, refrigerating, liquefying, heating, cooling or otherwise handling the fuel is to be examined, as far as practicable.
- 2) Means for inerting is to be examined.
- 3) Stopping of pumps and compressors upon emergency shut-down of the system is to be confirmed as far as practicable.

## **.5 Ventilating System**

Examination of the ventilation system, including portable ventilating equipment where fitted, is to be made for spaces containing fuel storage, fuel bunkering, and fuel supply units or components or associated systems, including air locks, pump rooms, compressor rooms, fuel preparation rooms, fuel valve rooms, control rooms and spaces containing gas burning equipment. Where alarms, such as differential pressure and loss of pressure alarms, are fitted, these should be operationally tested as far as practicable.

## **.6 Drip Trays**

Portable and fixed drip trays and insulation for the protection of the ship's structure in the event of leakage are to be examined.

## **.7 Hazardous Areas**

Electrical equipment and bulkhead/deck penetrations including access openings in hazardous areas are to be examined for continued suitability for their intended service and installation area.

## **.8 Electrical Bonding**

- 1) Electrical bonding arrangements in hazardous areas, including bonding straps where fitted, are to be examined.
- 2) Electrical bonding for gas piping is to be examined where applicable.

### **.9 Fuel Storage System**

- 1) External examination of the storage tanks including secondary barrier if fitted and accessible
- 2) General examination of the fuel storage hold place
- 3) Internal examination of tank connection space
- 4) External examination of tank and relief valves
- 5) Verification of satisfactory operation of tank monitoring system
- 6) Examination and testing of installed bilge alarms and means of drainage of the compartment
- 7) Testing of the remote and local closing of the installed main tank valve

### **.10 Fuel Bunkering System**

- 1) Examination of bunkering stations and the fuel bunkering system
- 2) Verification of satisfactory operation of the fuel bunkering control, monitoring and shutdown systems

### **.11 Fuel Supply System**

Examination of the fuel supply system during working condition as far as practicable

- 1) Verification of satisfactory operation of the fuel supply system control, monitoring and shut-down systems.
- 2) Testing of the remote and local closing of the master fuel valve for each engine compartment.

### **.12 Water spray systems**

Water spray systems are to be surveyed.

#### **1.4.2 Intermediate Survey**

At the Intermediate Survey, in addition to all the requirements for Annual Survey, the following items are to be surveyed.

- .1 Gas detectors, temperature sensors, pressure sensors, level indicators, and other equipment providing input to the fuel safety system are to be randomly tested to confirm satisfactory operating condition.
- .2 Proper response of the fuel safety system upon fault conditions is to be verified.
- .3 Alarms and shutdown function for gas compressor and engine are to be verified.

#### **1.4.3 Class Renewal Survey**

##### **.1 General**

The Class Renewal Survey is to include, in addition to the requirements of the Annual Survey, examination, tests and checks of sufficient extent to ensure that the fuel installations are in a satisfactory condition and is fit for its intended purpose for the new period of class of 5 years to be assigned, subject to proper maintenance and operation and to periodical surveys being carried out at the due dates.

## **.2 Fuel Handling and Piping**

All piping for fuel storage, fuel bunkering, and fuel supply such as venting, compressing, refrigerating, liquefying, heating storing, burning or otherwise handling the fuel and liquid nitrogen installations are to be examined. Removal of insulation from the piping and opening for examination may be required. Where deemed suspect, a hydrostatic test to 1,25 times the Maximum Allowable Relief Valve Setting (MARVS) for the pipeline is to be carried out. After reassembly, the complete piping is to be tested for leaks. Where water cannot be tolerated and the piping cannot be dried prior to putting the system into service, the Surveyor may accept alternative testing fluids or alternative means of testing.

## **.3 Fuel Valves**

Fuel valves in 1) and 2) are to be examined and proven operable. A random selection of valves is to be opened for examination.

- 1) Emergency shut-down valves, check valves, block and bleed valves, master gas valves, remote operating valves,
- 2) Isolating valves for pressure relief valves in the fuel storage, fuel bunkering, and fuel supply piping systems are to be examined and proven operable.

## **.4 Pressure Relief Valves**

### **.4.1 Fuel Storage Tank Pressure Relief Valves**

The pressure relief valves for the fuel storage tanks are to be opened for examination, adjusted, and function tested. If the tanks are equipped with relief valves with non-metallic membranes in the main or pilot valves, such non-metallic membranes are to be replaced.

### **.4.2 Fuel Supply and Bunkering Piping Pressure Relief Valves**

Pressure relief valves for the fuel supply and bunkering piping are to be opened for examination, adjusted, and function tested. Where a proper record of continuous overhaul and retesting of individually identifiable relief valves is maintained, consideration will be given to acceptance on the basis of opening, internal examination, and testing of a representative sampling of valves, including each size and type of liquefied gas or vapor relief valve in use, provided there is logbook evidence that the remaining valves have been overhauled and tested since crediting of the previous Class Renewal Survey.

### **.4.3 Pressure/Vacuum Relief Valves**

The pressure/vacuum relief valves, rupture disc and other pressure relief devices for interbarrier spaces and hold spaces are to be opened, examined, tested and readjusted as necessary, depending on their design.

## **.5 Fuel Handling Equipment**

Fuel pumps, compressors, process pressure vessels, inert gas generators, heat exchangers and other components used in connection with fuel handling are to be examined as required in the Rules for Classification and Construction [Part 1 Seagoing Ships](#).

## **.6 Electrical Equipment**

- 1) Examination of electrical equipment to include the physical condition of electrical cables and supports, intrinsically safe, explosion proof, or increased safety features of electrical equipment.
- 2) Functional testing of pressurized equipment and associated alarms.

- 3) Testing of systems for de-energizing electrical equipment which is not certified for use in hazardous areas.
- 4) An electrical insulation resistance test of the circuits terminating in, or passing through, the hazardous zones and spaces is to be carried out.

## .7 Safety Systems

Gas detectors, temperature sensors, pressure sensors, level indicators, and other equipment providing input to the fuel safety system are to be tested to confirm satisfactory operating condition.

- 1) Proper response of the fuel safety system upon fault conditions is to be verified.
- 2) Pressure, temperature and level indicating equipment are to be calibrated in accordance with the manufacturer's requirements.

## .8 Fuel Storage Tanks

Fuel storage tanks are to be examined in accordance with an approved survey plan that includes the following inspection items.

- 1) All Fuel tanks are to be examined internally. Vacuum insulated independent fuel storage tanks of type C without access openings need not be examined internally. Where fitted with access opening (such as manholes, cleaning holes, inspection holes, etc.), the vacuum monitoring system should be examined and records should be reviewed.
- 2) Special attention is to be given to the fuel tank and insulation in way of chocks, supports and keys. The tank insulation and tank support arrangements should be visually examined. Removal of insulation may be required in order to verify the condition of the tank or the insulation itself if found necessary by the Surveyor. Non-destructive testing may be required if conditions raise doubt to the structural integrity.

Where the arrangement is such that the insulation cannot be examined, the surrounding structures of wing tanks, double bottom tanks and cofferdams are to be examined for cold spots when the fuel tanks are in the cold condition unless voyage records together with the instrumentation give sufficient evidence of the integrity of the insulation system.

- 3) Non-destructive testing:
  - A) Non-destructive testing is to supplement fuel tank inspection with special attention to be given to the integrity of the main structural members, tank shell and highly stressed parts, including welded connections as deemed necessary by the surveyor. However, for type C tanks, this does not mean that non-destructive testing can be dispensed with totally. The following items are, inter alia, considered as highly stressed parts:
    - fuel tanks supports and anti-rolling/anti-pitching devices
    - web frames or stiffening rings
    - swash bulkhead boundaries
    - dome and stump connections to tank shell
    - foundations for pumps, towers, ladders, etc.
    - pipe connections
  - B) For independent tanks type B, the extent of non-destructive testing shall be as given in a programme specially prepared for the fuel tank design.
- 4) The tightness of all fuel tanks is to be verified by an appropriate procedure. Provided that the effectiveness of the ship's gas detection equipment has been confirmed, it will be acceptable to utilize this equipment for the tightness test of independent tanks below deck.

- 5) Where findings of 1) to 4) or an examination of the voyage records raises doubts as to the structural integrity of a fuel tank, a hydraulic or hydro-pneumatic test is to be carried out. For independent tank type A and B, the test pressure is to be carried out in accordance with proper pressure based on design of each tank. For independent tanks type C, the test pressure is not to be less than 1,25 times the MARVS.
- 6) At every other Class Renewal Survey (i.e., 2nd, 4th, 6th, etc.), all independent fuel tanks type C are to be either:
- A) Hydraulically or hydro-pneumatically tested to 1,25 times MARVS, followed by non-destructive testing in accordance with 3) A), or
  - B) Subjected to a thorough, planned non-destructive testing. This testing is to be carried out in accordance with a programme specially prepared for the tank design. If a special programme does not exist, the following applies:
    - fuel tank supports and anti-rolling/anti-pitching devices,
    - stiffening rings,
    - Y-connections between tank shell and a longitudinal bulkhead of bilobe tanks,
    - swash bulkhead boundaries,
    - dome and sump connections to the tank shell,
    - foundations for pumps, towers, ladders etc.,
    - pipe connections.
- At least 10% of the length of the welded connections in each of the above mentioned areas is to be tested. This testing is to be carried out internally and externally as applicable. Insulation is to be removed as necessary for the required non-destructive testing.
- 7) As far as practicable all hold spaces and hull insulation (if provided), secondary barriers and tank supporting structures are to be visually examined. The secondary barrier of all tanks is to be checked for their effectiveness by means of a pressure/vacuum test, a visual examination or another acceptable method.
- 8) Membrane tanks systems,
- A) For membrane tank systems, inspection and testing are to be carried out in accordance with programmes specially prepared in accordance with an approved method for the actual tank system.
  - B) For membrane storage systems a tightness test of the primary and secondary barrier shall be carried out in accordance with the system designers' procedures and acceptance criteria as approved by BKI. Low differential pressure tests may be used for monitoring the fuel storage system performance, but are not considered an acceptable test for the tightness of the secondary barrier.
  - C) For membrane storage systems with glued secondary barriers if the designer's threshold values are exceeded, an investigation is to be carried out and additional testing such as thermographic or acoustic emissions testing should be carried out.
- 9) The pressure/vacuum relief valves, rupture disc and other pressure relief devices for interbarrier spaces and hold spaces are to be opened, examined, tested and readjusted as necessary, depending on their design.
- 10) The pressure relief valves for the fuel tanks are to be opened for examination, adjusted, function tested, and sealed. If the fuel tanks are equipped with relief valves with non-metallic membranes in the main or pilot valves, such non-metallic membranes are to be replaced. Where a proper record of continuous overhaul and retesting of individually identifiable relief valves is maintained, consideration will be given to acceptance on the basis of opening, internal examination, and testing

of a representative sampling of valves, including each size and type of liquefied gas or vapor relief valve in use, provided there is logbook evidence that the remaining valves have been overhauled and tested since crediting of the previous Class Renewal Survey.

*This page intentionally left blank*



## Section 2 General

2.1	Application	2-1
2.2	Definitions	2-1
2.3	Alternative Design	2-4

### 2.1 Application

**2.1.1** Unless expressly provided otherwise these guidelines applies to ships to which part G of SOLAS chapter II-1 applies.

**C2.1.2** The requirements in these Guidelines are specified on the basis of their application to the ship to which the SOLAS Convention applies. However, if it is difficult to comply with the requirements of these Guidelines due to the size of the ship, etc., special consideration may be given to the conditions provided that they meet the intent of the goal and function requirements concerned and provide an equivalent level of safety to the relevant sections.

### 2.2 Definitions

Unless otherwise stated below, definitions are as defined in SOLAS chapter II-2.

**2.2.1 Accident** means an uncontrolled event that may entail the loss of human life, personal injuries, environmental damage or the loss of assets and financial interests.

**2.2.2 Breadth (B)** means the greatest moulded breadth of the ship at or below the deepest draught (summer load line draught) (refer to SOLAS chapter II-1/2.8)

**2.2.3 Bunkering** means the transfer of liquid or gaseous fuel from land based or floating facilities into a ships' permanent tanks or connection of portable tanks to the fuel supply system.

**2.2.4 Certified safe type** means electrical equipment that is certified safe by the relevant authorities recognized by the Administration for operation in a flammable atmosphere based on a reconized standard <sup>1)</sup>

**C2.2.4 The standard** is either accordance with the recommendation published by the International Electrotechnical Commission (IEC), in particular publication IEC 60092-502:1999, or with recognized standards at least equivalent. The certification of electrical equipment is to correspond to the category and group for methane gas.

**2.2.5 CNG** means compressed natural gas (see also 2.2.26 LNG)

**2.2.6 Control station** means those spaces defined in SOLAS chapter II-2 and additionally for IGF-Code, the engine control room.

**2.2.7 Design temperature** for selection of materials is the minimum temperature at which liquefied gas fuel may be loaded or transported in the liquefied gas fuel tanks.

**2.2.8 Design vapour pressure "P<sub>0</sub>"** is the maximum gauge pressure, at the top of the tank, to be used in the design of the tank.

---

<sup>1)</sup> Refer to IEC 60079 series, Explosive atmospheres and IEC 60092-502:1999 Electrical Installations in Ships - Tankers - Special Features.

**2.2.9 Double block and bleed valve** means a set of two valves in series in a pipe and a third valve enabling the pressure release from the pipe between those two valves. The arrangement may also consist of a two-way valve and a closing valve instead of three separate valves.

**C2.2.9 The double block and bleed valve** are refer to:

- [Rules for Ships Carrying Liquefied Gases in Bulk \(Pt.1, Vol.IX\) Sec. 16.4.5](#)
- Section [2.2.9](#) and [9.4.4](#) to [9.4.6](#)

**2.2.10 Dual fuel engines** means engines that employ fuel covered by this Code (with pilot fuel) and oil fuel. Oil fuels may include distillate and residual fuels.

**2.2.11 Enclosed space** means any space within which, in the absence of artificial ventilation, the ventilation will be limited and any explosive atmosphere will not be dispersed naturally.<sup>2)</sup>

**C2.2.11 Engine Room** is a machinery space or enclosure containing gas fuelled engine(s).

**2.2.12 ESD** means emergency shutdown.

**2.2.13 Explosion** means a deflagration event of uncontrolled combustion.

**2.2.14 Explosion pressure relief** means measures provided to prevent the explosion pressure in a container or an enclosed space exceeding the maximum overpressure the container or space is designed for, by releasing the overpressure through designated openings.

**2.2.15 Fuel containment system** is the arrangement for the storage of fuel including tank connections. It includes where fitted, a primary and secondary barrier, associated insulation and any intervening spaces, and adjacent structure if necessary for the support of these elements. If the secondary barrier is part of the hull structure it may be a boundary of the fuel storage hold space.

The spaces around the fuel tank are defined as follows:

**.1 Fuel storage hold space** is the space enclosed by the ship's structure in which a fuel containment system is situated. If tank connections are located in the fuel storage hold space, it will also be a tank connection space;

**.2 Interbarrier space** is the space between a primary and a secondary barrier, whether or not completely or partially occupied by insulation or other material; and

**.3 Tank connection space** is a space surrounding all tank connections and tank valves that is required for tanks with such connections in enclosed spaces.<sup>3)</sup>

**2.2.16 Filling limit (FL)** means the maximum liquid volume in a fuel tank relative to the total tank volume when the liquid fuel has reached the reference temperature.

**2.2.17 Fuel preparation room** means any space containing pumps, compressors and/or vaporizers for fuel preparation purposes.<sup>4)</sup>

**2.2.18 Gas** means a fluid having a vapour pressure exceeding 0,28 MPa absolute at a temperature of 37,8°C.

**2.2.19 Gas consumer** means any unit within the vessel using gas as a fuel.

**C2.2.19 Gas engine** means either a **DF** engine or a **SF** engine.

<sup>2)</sup> See also definition in IEC 60092-502:1999.

<sup>3)</sup> For interpretation refer to [Guidance for Code and Convention Interpretations \(Pt.1, Vol.Y\) Sec.5,GF 3.](#)

<sup>4)</sup> For interpretation refer to [Guidance for Code and Convention Interpretations \(Pt.1, Vol.Y\) Sec.5,GF 4.](#)

**2.2.20 Gas only engine ("SF engine")** means an engine capable of operating only on gas, and not able to switch over to operation on any other type of fuel.

**C2.2.20 Gas piping** means piping containing gas or air / gas mixtures, including venting pipes.

**C2.2.21 Gas Valve Unit (GVU)** is a set of manual shutoff valves, actuated shut-off and venting valves, gas pressure sensors and transmitters, gas temperature sensors and transmitters, gas pressure control valve and gas filter used to control the gas supply to each gas consumer. It also includes a connection for inert gas purging.

**C2.2.22 IGC Code** means the International Code for the Construction and Equipment of Ships Carrying Liquefied Gases in Bulk (as amended by IMO Resolutions MSC.370(93), MSC.411(97), MSC.441(99)), MSC.476(102), and MSC.492(104)).

**C2.2.23 Organization** means the International Maritime Organisation (IMO).

**C2.2.24 IGF Code** means the International Code of Safety for Ships Using Gases or other Low-Flashpoint Fuels (IMO Resolution MSC.391(95), as amended by Resolution MSC.422(98), MSC.458(101), and MSC.475(102)).

**2.2.21 Hazardous area** means an area in which an explosive gas atmosphere is or may be expected to be present, in quantities such as to require special precautions for the construction, installation and use of equipment.

**2.2.22 High pressure** means a maximum working pressure greater than 1,0 MPa.

**2.2.23 Independent tanks** are self-supporting, do not form part of the ship's hull and are not essential to the hull strength.

**2.2.24 LEL** means the lower explosive limit.

**2.2.25 Length (L)** is the length as defined in the International Convention on Load Lines in force.

**2.2.26 LNG** means liquefied natural gas.

**2.2.27 Loading limit (LL)** means the maximum allowable liquid volume relative to the tank volume to which the tank may be loaded.

**2.2.28 Low-flashpoint fuel** means gaseous or liquid fuel having a flashpoint lower than otherwise permitted under paragraph 2.1.1 of SOLAS regulation II-2/4.

**C2.2.28 Low pressure gas** means gas with a pressure up to 10 bar (1 MPa).

**2.2.29 MARVS** means the maximum allowable relief valve setting.

**2.2.30 MAWP** means the maximum allowable working pressure of a system component or tank.

**2.2.31 Membrane tanks** are non-self-supporting tanks that consist of a thin liquid and gas tight layer (membrane) supported through insulation by the adjacent hull structure.

**2.2.32 Multi-fuel engines** means engines that can use two or more different fuels that are separate from each other.

**2.2.33 Non-hazardous area** means an area in which an explosive gas atmosphere is not expected to be present in quantities such as to require special precautions for the construction, installation and use of equipment.

**2.2.34 Open deck** means a deck having no significant fire risk that at least is open on both ends/sides, or is open on one end and is provided with adequate natural ventilation that is effective over the entire length of the deck through permanent openings distributed in the side plating or deckhead.

**C2.2.34 Pilot fuel** means the fuel oil that is injected into the cylinder to ignite the main gas-air mixture on DF engines.

**2.2.35 Recognized standards** means applicable international or national standards acceptable to BKI or standards laid down and maintained by an organisation which complies with the standards adopted by IMO and which are recognized by BKI.

**2.2.36 Risk** is an expression for the combination of the likelihood and the severity of the consequences.

**2.2.37 Reference temperature** means the temperature corresponding to the vapour pressure of the fuel in a fuel tank at the set pressure of the PRVs.

**C2.2.36 Safety Concept** is a document describing the safety philosophy with regard to gas as fuel. It describes how risks associated with this type of fuel are controlled under reasonably foreseeable abnormal conditions as well as possible failure scenarios and their control measures.

**Note:**

*A detailed evaluation regarding the hazard potential of injury from a possible explosion is to be carried out and reflected in the safety concept of the engine.*

**2.2.38 Secondary barrier** is the liquid-resisting outer element of a fuel containment system designed to afford temporary containment of any envisaged leakage of liquid fuel through the primary barrier and to prevent the lowering of the temperature of the ship's structure to an unsafe level.

**2.2.39 Semi-enclosed space** means a space where the natural conditions of ventilation are notably different from those on open deck due to the presence of structure such as roofs, windbreaks and bulkheads and which are so arranged that dispersion of gas may not occur.<sup>5)</sup>

**2.2.40 Source of release** means a point or location from which a gas, vapour, mist or liquid may be released into the atmosphere so that an explosive atmosphere could be formed.

**2.2.41 Unacceptable loss of power** means that it is not possible to sustain or restore normal operation of the propulsion machinery in the event of one of the essential auxiliaries becoming inoperative, in accordance with SOLAS regulation II-1/26.3.

**2.2.42 Vapour pressure** is the equilibrium pressure of the saturated vapour above the liquid, expressed in MPa absolute at a specified temperature.

**2.2.43 Ship constructed on or after 1 January 2024 means:**

- .1 for which the building contract is placed on or after 1 January 2024; or
- .2 in the absence of a building contract, the keels of which are laid or which are at a similar stage of construction on or after 1 July 2024; or
- .3 the delivery of which is on or after 1 January 2028

## 2.3 Alternative Design

**2.3.1** These Guidelines contains functional requirements for all appliances and arrangements related to the usage of low-flashpoint fuels.

**2.3.2** Fuels, appliances and arrangements of low-flashpoint fuel systems may either:

- .1 deviate from those set out in these Guidelines, or
- .2 be designed for use of a fuel not specifically addressed in this Guidelines.

Such fuels, appliances and arrangements can be used provided that these meet the intent of the goal and functional requirements concerned and provide an equivalent level of safety of the relevant Sections.

**2.3.3** The equivalence of the alternative design shall be demonstrated as specified in SOLAS regulation II-1/55 and approved by the BKI. However, the BKI shall not allow operational methods or procedures to be applied as an alternative to a particular fitting, material, appliance, apparatus, item of equipment, or type thereof which is prescribed by these Guidelines.

<sup>5)</sup> Refer also to IEC 60092-502:1999 Electrical Installations in Ships – Tankers – Special Features.

## Section 3 Goal and Functional Requirements

3.1	Goal . . . . .	3-1
3.2	Functional requirements . . . . .	3-1

### 3.1 Goal

The goal of these Guidelines is to provide for safe and environmentally-friendly design, construction and operation of ships and in particular their installations of systems for propulsion machinery, auxiliary power generation machinery and/or other purpose machinery using gas or low-flashpoint fuel as fuel.

### 3.2 Functional requirements

**3.2.1** The safety, reliability and dependability of the systems shall be equivalent to that achieved with new and comparable conventional oil-fuelled main and auxiliary machinery.

**3.2.2** The probability and consequences of fuel-related hazards shall be limited to a minimum through arrangement and system design, such as ventilation, detection and safety actions. In the event of gas leakage or failure of the risk reducing measures, necessary safety actions shall be initiated.

**3.2.3** The design philosophy shall ensure that risk reducing measures and safety actions for the gas fuel installation do not lead to an unacceptable loss of power.

**3.2.4** Hazardous areas shall be restricted, as far as practicable, to minimize the potential risks that might affect the safety of the ship, persons on board, and equipment.

**3.2.5** Equipment installed in hazardous areas shall be minimized to that required for operational purposes and shall be suitably and appropriately certified.

**3.2.6** Unintended accumulation of explosive, flammable or toxic gas concentrations shall be prevented.

**3.2.7** System components shall be protected against external damages.

**3.2.8** Sources of ignition in hazardous areas shall be minimized to reduce the probability of explosions.

**3.2.9** It shall be arranged for safe and suitable fuel supply, storage and bunkering arrangements capable of receiving and containing the fuel in the required state without leakage. Other than when necessary for safety reasons, the system shall be designed to prevent venting under all normal operating conditions including idle periods.

**C3.2.9** The BKI may waive this requirement in a state of emergency or in cases where the venting of specific cargo specially is approved by the Society BKI as a method of control of tank pressure and temperature.

**3.2.10** Piping systems, containment and over-pressure relief arrangements that are of suitable design, construction and installation for their intended application shall be provided.

**3.2.11** Machinery, systems and components shall be designed, constructed, installed, operated, maintained and protected to ensure safe and reliable operation.

**3.2.12** Fuel containment system and machinery spaces containing source that might release gas into the space shall be arranged and located such that a fire or explosion in either will not lead to an unacceptable loss of power or render equipment in other compartments inoperable.

**3.2.13** Suitable control, alarm, monitoring and shutdown systems shall be provided to ensure safe and reliable operation.

**3.2.14** Fixed gas detection suitable for all spaces and areas concerned shall be arranged.

**3.2.15** Fire detection, protection and extinction measures appropriate to the hazards concerned shall be provided.

**3.2.16** Commissioning, trials and maintenance of fuel systems and gas utilization machinery shall satisfy the goal in terms of safety, availability and reliability.

**3.2.17** The technical documentation shall permit an assessment of the compliance of the system and its components with the applicable rules, guidelines, design standards used and the principles related to safety, availability, maintainability and reliability.

**3.2.18** A single failure in a technical system or component shall not lead to an unsafe or unreliable situation.

## Section 4 General Requirements

4.1	Goal . . . . .	4-1
4.2	Risk assessment . . . . .	4-1
4.3	Limitation of explosion consequences . . . . .	4-1

### 4.1 Goal

The goal of this Section is to ensure that the necessary assessments of the risks involved are carried out in order to eliminate or mitigate any adverse effect to the persons on board, the environment or the ship.

### 4.2 Risk assessment

**4.2.1** A risk assessment shall be conducted to ensure that risks arising from the use of low-flashpoint fuels affecting persons on board, the environment, the structural strength or the integrity of the ship are addressed. Consideration shall be given to the hazards associated with physical layout, operation and maintenance, following any reasonably foreseeable failure.

**4.2.2** For ships using natural gas as fuel, the risk assessment required by 4.2.1 need only be conducted where explicitly required by paragraphs 5.10.5, 5.12.3, 6.4.1.1, 6.4.15.4.7.2, 8.3.1.1, 13.4.1, 13.7 and 15.8.1.10 as well as by paragraphs 4.4 and 6.8 of the Annex A.

**4.2.3** The risks shall be analysed using acceptable and recognized risk analysis techniques, and loss of function, component damage, fire, explosion and electric shock shall as a minimum be considered. The analysis shall ensure that risks are eliminated wherever possible. Risks which cannot be eliminated shall be mitigated as necessary. Details of risks, and the means by which they are mitigated, shall be documented to the satisfaction of the BKI.

### 4.3 Limitation of explosion consequences

An explosion in any space containing any potential sources of release and potential ignition sources shall not:

- 4.3.1** cause damage to or disrupt the proper functioning of equipment/systems located in any space other than that in which the incident occurs;
- 4.3.2** damage the ship in such a way that flooding of water below the main deck or any progressive flooding occur;
- 4.3.3** damage work areas or accommodation in such a way that persons who stay in such areas under normal operating conditions are injured;
- 4.3.4** disrupt the proper functioning of control stations and switchboard rooms necessary for power distribution;
- 4.3.5** damage life-saving equipment or associated launching arrangements;
- 4.3.6** disrupt the proper functioning of firefighting equipment located outside the explosion-damaged space;
- 4.3.7** affect other areas of the vessel in such a way that chain reactions involving, inter alia, cargo, gas and bunker oil may arise; or
- 4.3.8** prevent persons access to life saving appliances or impede escape routes.

*This page intentionally left blank*



## Section 5 Ship Design and Arrangement

5.1	Goal . . . . .	5-1
5.2	Functional requirements . . . . .	5-1
5.3	General requirements . . . . .	5-1
5.4	Machinery space concepts . . . . .	5-4
5.5	Gas safe machinery space . . . . .	5-4
5.6	ESD-protected machinery spaces . . . . .	5-4
5.7	Location and protection of fuel piping . . . . .	5-5
5.8	Fuel preparation room design . . . . .	5-5
5.9	Bilge systems . . . . .	5-5
5.10	Requirements for drip trays . . . . .	5-6
5.11	Requirements for arrangement of entrances and other openings in enclosed spaces . . . . .	5-6
5.12	Requirements for Airlocks . . . . .	5-6

### 5.1 Goal

The goal of this Section is to provide for safe location, space arrangements and mechanical protection of power generation equipment, fuel storage systems, fuel supply equipment and refuelling systems.

**C5.1.1** Fuel in the context of this Section means natural gas, either in its liquefied or gaseous state.

### 5.2 Functional requirements

**5.2.1** This Section is related to functional requirements in 3.2.1 to 3.2.3, 3.2.5, 3.2.6, 3.2.8, 3.2.12 to 3.2.15 and 3.2.17. In particular, the following apply:

- .1 the fuel tank(s) shall be located in such a way that the probability for the tank(s) to be damaged following a collision or grounding is reduced to a minimum taking into account the safe operation of the ship and other hazards that may be relevant to the ship;
- .2 fuel containment systems, fuel piping and other fuel sources of release shall be so located and arranged that released gas is lead to a safe location in the open air;
- .3 the access or other openings to spaces containing fuel sources of release shall be so arranged that flammable, asphyxiating or toxic gas cannot escape to spaces that are not designed for the presence of such gases
- .4 fuel piping shall be protected against mechanical damage;
- .5 the propulsion and fuel supply system shall be so designed that safety actions after any gas leakage do not lead to an unacceptable loss of power; and
- .6 the probability of a gas explosion in a machinery space with gas or low-flashpoint fuelled machinery shall be minimized.

### 5.3 General requirements

**5.3.1** Fuel storage tanks shall be protected against mechanical damage.

**5.3.2** Fuel storage tanks and or equipment located on open deck shall be located to ensure sufficient natural ventilation, so as to prevent accumulation of escaped gas.

**5.3.3** The fuel tank(s) shall be protected from external damage caused by collision or grounding in the following way:

.1 The fuel tanks shall be located at a minimum distance of  $B/5$  or 11,5 m, whichever is less, measured inboard from the ship side at right angles to the centreline at the level of the summer load line draught; where:

**B** is the greatest moulded breadth of the ship at or below the deepest draught (summer load line draught) (refer to SOLAS regulation II-1/2.8).

.2 The boundaries of each fuel tank shall be taken as the extreme outer longitudinal, transverse and vertical limits of the tank structure including its tank valves.

.3 For independent tanks the protective distance shall be measured to the tank shell (the primary barrier of the tank containment system). For membrane tanks the distance shall be measured to the bulkheads surrounding the tank insulation.

.4 In no case shall the boundary of the fuel tank be located closer to the shell plating or aft terminal of the ship than as follows:

.4.1 For passenger ships:  $B/10$  but in no case less than 0,8 m. However, this distance need not be greater than  $B/15$  or 2 m whichever is less where the shell plating is located inboard of  $B/5$  or 11,5m, whichever is less, as required by 5.3.3.1.

.4.2 For cargo ships:

.4.2.1 for  $V_c$  below or equal  $1000 \text{ m}^3$ , 0,8 m;

.4.2.2 for  $1000 \text{ m}^3 < V_c < 5000 \text{ m}^3$ ,  $0,75 + V_c \times 0,2/4000$  m;

.4.2.3 for  $5000 \text{ m}^3 \leq V_c < 30\,000 \text{ m}^3$ ,  $0,8 + V_c/25\,000$  m; and

.4.2.4 for  $V_c \geq 30\,000 \text{ m}^3$ , 2 m,

where:

$V_c$  corresponds to 100% of the gross design volume of the individual fuel tank at 20°C, including domes and appendages.

.5 The lowermost boundary of the fuel tank(s) shall be located above the minimum distance of  $B/15$  or 2,0 m, whichever is less, measured from the moulded line of the bottom shell plating at the centreline.

.6 For multihull ships the value of **B** may be specially considered.

.7 The fuel tank(s) shall be abaft a transverse plane at  $0,08L$  measured from the forward perpendicular in accordance with SOLAS regulation II-1/8.1 for passenger ships, and abaft the collision bulkhead for cargo ships.

where:

**L** is the length as defined in the International Convention on Load Lines (refer to SOLAS regulation II-1/2.5).

.8 For ships with a hull structure providing higher collision and/or grounding resistance, fuel tank location regulations may be specially considered in accordance with 2.3.

**5.3.4** As an alternative to 5.3.3.1 above, the following calculation method may be used to determine the acceptable location of the fuel tanks:

.1 The value  $f_{CN}$  calculated as described in the following shall be less than 0,02 for passenger ships and 0,04 for cargo ships<sup>1)</sup>.

<sup>1)</sup> The value  $f_{CN}$  accounts for collision damages that may occur within a zone limited by the longitudinal projected boundaries of the fuel tank only, and cannot be considered or used as the probability for the fuel tank to become damaged given a collision. The real probability will be higher when accounting for longer damages that include zones forward and aft of the fuel tank.

.2 The  $f_{CN}$  is calculated by the following formulation:

$$f_{CN} = f_1 \cdot f_t \cdot f_v$$

where:

$f_1$  is calculated by use of the formulations for factor p contained in SOLAS regulation II-1/7-1.1.1.1. The value of  $x_1$  shall correspond to the distance from the aft terminal to the aftmost boundary of the fuel tank and the value of  $x_2$  shall correspond to the distance from the aft terminal to the foremost boundary of the fuel tank.

$f_t$  is calculated by use of the formulations for factor r contained in SOLAS regulation II-1/7-1.1.2, and reflects the probability that the damage penetrates beyond the outer boundary of the fuel tank. The formulation is :

$$f_t = 1 - r(x_1, x_2, b)^2$$

$f_v$  is calculated by use of the formulations for factor v contained in SOLAS regulation II-1/7-2.6.1.1 and reflects the probability that the damage is not extending vertically above the lowermost boundary of the fuel tank. The formulations to be used are:

$$f_v = 1,0 - 0,8 \left( \frac{(H - d)}{7,8} \right)$$

, if (H-d) is less than or equal to 7,8m.  $f_v$  shall not be taken greater than 1.

$$f_v = 0,2 - 0,2 \left( \frac{(H - d) - 7,8}{4,7} \right)$$

, in all other cases  $f_v$  shall not be taken less than 0.

where:

H = the distance from baseline, in metres, to the lowermost boundary of the fuel tank;  
and

d = the deepest draught (summer load line draught).

.3 The boundaries of each fuel tank shall be taken as the extreme outer longitudinal, transverse and vertical limits of the tank structure including its tank valves.

.4 For independent tanks the protective distance shall be measured to the tank shell (the primary barrier of the tank containment system). For membrane tanks the distance shall be measured to the bulkheads surrounding the tank insulation.

.5 In no case shall the boundary of the fuel tank be located closer to the shell plating or aft terminal of the ship than as follows:

.5.1 For passenger ships:  $B/10$  but in no case less than 0,8 m. However, this distance need not be greater than  $B/15$  or 2 m whichever is less where the shell plating is located inboard of  $B/5$  or 11,5 m, whichever is less, as required by 5.3.3.1.

.5.2 For cargo ships:

.5.2.1 for  $V_c$  below or equal  $1000 \text{ m}^3$ , 0,8 m;

.5.2.2 for  $1000 \text{ m}^3 < V_c < 5000 \text{ m}^3$ ,  $0,75 + V_c \times 0,2/4000$  m;

.5.2.3 for  $5000 \text{ m}^3 \leq V_c < 30\,000 \text{ m}^3$ ,  $0,8 + V_c/25\,000$  m; and

.5.2.4 for  $V_c \geq 30\,000\text{ m}^3$ , 2m,

where:

$V_c$  corresponds to 100% of the gross design volume of the individual fuel tank at 20°C, including domes and appendages.

.6 In case of more than one non-overlapping fuel tank located in the longitudinal direction,  $f_{CN}$  shall be calculated in accordance with paragraph 5.3.4.2 for each fuel tank separately. The value used for the complete fuel tank arrangement is the sum of all values for  $f_{CN}$  obtained for each separate tank.

.7 In case the fuel tank arrangement is unsymmetrical about the centreline of the ship, the calculations of  $f_{CN}$  shall be calculated on both starboard and port side and the average value shall be used for the assessment. The minimum distance as set forth in paragraph 5.3.4.5 shall be met on both sides.

.8 For ships with a hull structure providing higher collision and/or grounding resistance, fuel tank location regulations may be specially considered in accordance with 2.3.

5.3.5 When fuel is carried in a fuel containment system requiring a complete or partial secondary barrier:

- .1 fuel storage hold spaces shall be segregated from the sea by a double bottom; and
- .2 the ship shall also have a longitudinal bulkhead forming side tanks.

## 5.4 Machinery space concepts

5.4.1 In order to minimize the probability of a gas explosion in a machinery space with gas-fuelled machinery one of these two alternative concepts may be applied <sup>3)</sup>:

.1 Gas safe machinery spaces: Arrangements in machinery spaces are such that the spaces are considered gas safe under all conditions, normal as well as abnormal conditions, i.e. inherently gas safe.

In a gas safe machinery space a single failure cannot lead to release of fuel gas into the machinery space.

.2 ESD-protected machinery spaces: Arrangements in machinery spaces are such that the spaces are considered non-hazardous under normal conditions, but under certain abnormal conditions may have the potential to become hazardous. In the event of abnormal conditions involving gas hazards, emergency shutdown (ESD) of non-safe equipment (ignition sources) and machinery shall be automatically executed while equipment or machinery in use or active during these conditions shall be of a certified safe type.

In an ESD protected machinery space a single failure may result in a gas release into the space. Venting is designed to accommodate a probable maximum leakage scenario due to technical failures. Failures leading to dangerous gas concentrations, e.g. gas pipe ruptures or blow out of gaskets are covered by explosion pressure relief devices and ESD arrangements.

## 5.5 Gas safe machinery space

5.5.1 A single failure within the fuel system shall not lead to a gas release into the machinery space.

5.5.2 All fuel piping within machinery space boundaries shall be enclosed in a gas tight enclosure in accordance with 9.6.

## 5.6 ESD-protected machinery spaces

5.6.1 ESD protection shall be limited to machinery spaces that are certified for periodically unattended operation.

5.6.2 Measures shall be applied to protect against explosion, damage of areas outside of the machinery space and ensure redundancy of power supply. The following arrangement shall be provided but may not be limited to:

<sup>3)</sup> For interpretation refer to [Guidance for Code and Convention Interpretations \(Pt.1, Vol.Y\) Sec.5,GF 5](#).

- .1 gas detector;
- .2 shut off valve;
- .3 redundancy; and
- .4 efficient ventilation.

**5.6.3** Gas supply piping within machinery spaces may be accepted without a gastight external enclosure on the following conditions:

- .1 Engines for generating propulsion power and electric power shall be located in two or more machinery spaces not having any common boundaries unless it can be documented that a single casualty will not affect both spaces.
- .2 The gas machinery space shall contain only a minimum of such necessary equipment, components and systems as are required to ensure that the gas machinery maintains its function.
- .3 A fixed gas detection system arranged to automatically shut down the gas supply, and disconnect all electrical equipment or installations not of a certified safe type, shall be fitted.

**5.6.4** Distribution of engines between the different machinery spaces shall be such that shutdown of fuel supply to any one machinery space does not lead to an unacceptable loss of power.

**5.6.5** ESD protected machinery spaces separated by a single bulkhead shall have sufficient strength to withstand the effects of a local gas explosion in either space, without affecting the integrity of the adjacent space and equipment within that space.

**5.6.6** ESD protected machinery spaces shall be designed to provide a geometrical shape that will minimize the accumulation of gases or formation of gas pockets.

**5.6.7** The ventilation system of ESD-protected machinery spaces shall be arranged in accordance with [13.5](#).

## **5.7 Location and protection of fuel piping**

**5.7.1** Fuel pipes shall not be located less than 800 mm from the ship's side.

**5.7.2** Fuel piping shall not be led directly through accommodation spaces, service spaces, electrical equipment rooms or control stations as defined in the SOLAS Convention.

**5.7.3** Fuel pipes led through ro-ro spaces, special category spaces and on open decks shall be protected against mechanical damage.

**5.7.4** Gas fuel piping in ESD protected machinery spaces shall be located as far as practicable from the electrical installations and tanks containing flammable liquids.

**5.7.5** Gas fuel piping in ESD protected machinery spaces shall be protected against mechanical damage.

## **5.8 Fuel preparation room design**

Fuel preparation rooms shall be located on an open deck, unless those rooms are arranged and fitted in accordance with the regulations of these Guidelines for tank connection spaces. <sup>4)</sup>

## **5.9 Bilge systems**

**5.9.1** Bilge systems installed in areas where fuel covered by these Guidelines can be present shall be segregated from the bilge system of spaces where fuel cannot be present.

---

<sup>4)</sup> For interpretation refer to [Guidance for Code and Convention Interpretations \(Pt.1, Vol.Y\) Sec.5,GF 6](#).

**5.9.2** Where fuel is carried in a fuel containment system requiring a secondary barrier, suitable drainage arrangements for dealing with any leakage into the hold or insulation spaces through the adjacent ship structure shall be provided. The bilge system shall not lead to pumps in safe spaces. Means of detecting such leakage shall be provided.

**5.9.3** The hold or interbarrier spaces of type A independent tanks for liquid gas shall be provided with a drainage system suitable for handling liquid fuel in the event of fuel tank leakage or rupture.

## **5.10 Requirements for drip trays**

**5.10.1** Drip trays shall be fitted where leakage may occur which can cause damage to the ship structure or where limitation of the area which is effected from a spill is necessary.

**5.10.2** Drip trays shall be made of suitable material.

**5.10.3** The drip tray shall be thermally insulated from the ship's structure so that the surrounding hull or deck structures are not exposed to unacceptable cooling, in case of leakage of liquid fuel.

**5.10.4** Each tray shall be fitted with a drain valve to enable rain water to be drained over the ship's side.

**5.10.5** Each tray shall have a sufficient capacity to ensure that the maximum amount of spill according to the risk assessment can be handled.

## **5.11 Requirements for arrangement of entrances and other openings in enclosed spaces**

**5.11.1** Direct access shall not be permitted from a non-hazardous area to a hazardous area. Where such openings are necessary for operational reasons, an airlock which complies with 5.12 shall be provided.

**5.11.2** If the fuel preparation room is approved located below deck, the room shall, as far as practicable, have an independent access direct from the open deck. Where a separate access from deck is not practicable, an airlock which complies with 5.12 shall be provided.

**5.11.3** Unless access to the tank connection space is independent and direct from open deck it shall be arranged as a bolted hatch. The space containing the bolted hatch will be a hazardous space.

**5.11.4** If the access to an ESD-protected machinery space is from another enclosed space in the ship, the entrances shall be arranged with an airlock which complies with 5.12.

**5.11.5** For inerted spaces access arrangements shall be such that unintended entry by personnel shall be prevented. If access to such spaces is not from an open deck, sealing arrangements shall ensure that leakages of inert gas to adjacent spaces are prevented.

## **5.12 Requirements for Airlocks**

**5.12.1** An airlock is a space enclosed by gastight bulkheads with two substantially gastight doors spaced at least 1,5 m and not more than 2,5 m apart. Unless subject to the requirements of the International Convention on Load Lines, the door sill shall not be less than 300 mm in height. The doors shall be self-closing without any holding back arrangements.

**5.12.2** Airlocks shall be mechanically ventilated at an overpressure relative to the adjacent hazardous area or space.

**5.12.3** The airlock shall be designed in a way that no gas can be released to safe spaces in case of the most critical event in the gas dangerous space separated by the airlock. The events shall be evaluated in the risk analysis according to 4.2.

**5.12.4** Airlocks shall have a simple geometrical form. They shall provide free and easy passage, and shall have a deck area not less than 1,5 m<sup>2</sup>. Airlocks shall not be used for other purposes, for instance as store rooms.

**5.12.5** An audible and visual alarm system to give a warning on both sides of the airlock shall be provided to indicate if more than one door is moved from the closed position.

**5.12.6** For non-hazardous spaces with access from hazardous spaces below deck where the access is protected by an airlock, upon loss of under pressure in the hazardous space access to the space is to be restricted until the ventilation has been reinstated. Audible and visual alarms shall be given at a manned location to indicate both loss of pressure and opening of the airlock doors when pressure is lost.

**5.12.7** Essential equipment required for safety shall not be de-energized and shall be of a certified safe type. This may include lighting, fire detection, public address, general alarms systems.

*This page intentionally left blank*



## Section 6 Ship Design and Arrangement

6.1	Goal . . . . .	6-1
6.2	Functional requirements . . . . .	6-1
6.3	General Requirements . . . . .	6-2
6.4	Liquefied gas fuel containment . . . . .	6-2
6.5	Portable liquefied gas fuel tanks . . . . .	6-28
6.6	CNG fuel containment . . . . .	6-29
6.7	Pressure relief system . . . . .	6-29
6.8	Loading limit for liquefied gas fuel tanks . . . . .	6-33
6.9	Maintaining of fuel storage condition . . . . .	6-34
6.10	Atmospheric control within the fuel containment system . . . . .	6-35
6.11	Atmosphere control within fuel storage hold spaces (Fuel containment systems other than type C independent tanks) . . . . .	6-35
6.12	Environmental control of spaces surrounding type C independent tanks . . . . .	6-36
6.13	Requirement on inerting . . . . .	6-36
6.14	Inert gas production and storage on board . . . . .	6-36

### 6.1 Goal

The goal of this Section is to provide that gas storage is adequate so as to minimize the risk to personnel, the ship and the environment to a level that is equivalent to a conventional oil fuelled ship.

**6.1.1** Fuel in the context of this Section means natural gas, either in its liquefied or gaseous state.

### 6.2 Functional requirements

This Section is related to functional requirements in 3.2.1 to 3.2.2, 3.2.5, and 3.2.8, to 3.2.17. In particular, the following apply:

**6.2.1** the fuel containment system shall be so designed that a leak from the tank or its connections does not endanger the ship, persons on board or the environment. Potential dangers to be avoided include:

- .1 exposure of ship materials to temperatures below acceptable limits <sup>1)</sup>;
- .2 flammable fuels spreading to locations with ignition sources;
- .3 toxicity potential and risk of oxygen deficiency due to fuels and inert gases;
- .4 restriction of access to muster stations, escape routes and life-saving appliances (LSA); and
- .5 reduction in availability of LSA.

**6.2.2** the pressure and temperature in the fuel tank shall be kept within the design limits of the containment system and possible carriage requirements of the fuel;

**6.2.3** the fuel containment arrangement shall be so designed that safety actions after any gas leakage do not lead to an unacceptable loss of power; and

**6.2.4** if portable tanks are used for fuel storage, the design of the fuel containment system shall be equivalent to permanent installed tanks as described in this Section.

---

<sup>1)</sup> For interpretation refer to [Guidance for Code and Convention Interpretations \(Pt.1, Vol.Y\) Sec.5,GF 6](#).

### 6.3 General Requirements

**6.3.1** Natural gas in a liquid state may be stored with a maximum allowable relief valve setting (MARVS) of up to 1,0 MPa.

**6.3.2** The Maximum Allowable Working Pressure (MAWP) of the gas fuel tank shall not exceed 90% of the Maximum Allowable Relief Valve Setting (MARVS).

**6.3.3** A fuel containment system located below deck shall be gas tight towards adjacent spaces.

**6.3.4** All tank connections, fittings, flanges and tank valves must be enclosed in gas tight tank connection spaces, unless the tank connections are on open deck. The space shall be able to safely contain leakage from the tank in case of leakage from the tank connections.

**6.3.5** Pipe connections to the fuel storage tank shall be mounted above the highest liquid level in the tanks, except for fuel storage tanks of type C. Connections below the highest liquid level may however also be accepted for other tank types after special consideration by the BKI.

**6.3.6** Piping between the tank and the first valve which release liquid in case of pipe failure shall have equivalent safety as the type C tank, with dynamic stress not exceeding the values given in [6.4.15.3.1.2](#).

**6.3.7** The material of the bulkheads of the tank connection space shall have a design temperature corresponding with the lowest temperature it can be subject to in a probable maximum leakage scenario. The tank connection space shall be designed to withstand the maximum pressure build up during such a leakage. Alternatively, pressure relief venting to a safe location (mast) can be provided.

**6.3.8** The probable maximum leakage into the tank connection space shall be determined based on detail design, detection and shut down systems.

**6.3.9** If piping is connected below the liquid level of the tank it has to be protected by a secondary barrier up to the first valve.

**6.3.10** If liquefied gas fuel storage tanks are located on open deck the ship steel shall be protected from potential leakages from tank connections and other sources of leakage by use of drip trays<sup>2)</sup>. The material is to have a design temperature corresponding to the temperature of the fuel carried at atmospheric pressure. The normal operation pressure of the tanks shall be taken into consideration for protecting the steel structure of the ship.

**6.3.11** Means shall be provided whereby liquefied gas in the storage tanks can be safely emptied.

**6.3.12** It shall be possible to empty, purge and vent fuel storage tanks with fuel piping systems. Instructions for carrying out these procedures must be available on board. Inerting shall be performed with an inert gas prior to venting with dry air to avoid an explosion hazardous atmosphere in tanks and fuel pipes. See detailed regulations in [6.10](#).

### 6.4 Liquefied gas fuel containment

#### 6.4.1 General

.1 The risk assessment required in [4.2](#) shall include evaluation of the vessel's liquefied gas fuel containment system, and may lead to additional safety measures for integration into the overall vessel design.

.2 The design life of fixed liquefied gas fuel containment system shall not be less than the design life of the ship or 20 years, whichever is greater.

.3 The design life of portable tanks shall not be less than 20 years.

<sup>2)</sup> For interpretation refer to [Guidance for Code and Convention Interpretations \(Pt.1, Vol.Y\) Sec.5,GF 2](#).

.4 Liquefied gas fuel containment systems shall be designed in accordance with North Atlantic environmental conditions and relevant long-term sea state scatter diagrams for unrestricted navigation. Less demanding environmental conditions, consistent with the expected usage, may be accepted by the BKI for liquefied gas fuel containment systems used exclusively for restricted navigation. More demanding environmental conditions may be required for liquefied gas fuel containment systems operated in conditions more severe than the North Atlantic environment. <sup>3) 4)</sup>

.5 Liquefied gas fuel containment systems shall be designed with suitable safety margins:

.5.1 to withstand, in the intact condition, the environmental conditions anticipated for the liquefied gas fuel containment system's design life and the loading conditions appropriate for them, which shall include full homogeneous and partial load conditions and partial filling to any intermediate levels; and

.5.2 being appropriate for uncertainties in loads, structural modelling, fatigue, corrosion, thermal effects, material variability, aging and construction tolerances.

.6 The liquefied gas fuel containment system structural strength shall be assessed against failure modes, including but not limited to plastic deformation, buckling and fatigue. The specific design conditions that shall be considered for the design of each liquefied gas fuel containment system are given in 6.4.15. There are three main categories of design conditions:

.6.1 Ultimate Design Conditions – The liquefied gas fuel containment system structure and its structural components shall withstand loads liable to occur during its construction, testing and anticipated use in service, without loss of structural integrity. The design shall take into account proper combinations of the following loads:

.6.1.1 internal pressure;

.6.1.2 external pressure;

.6.1.3 dynamic loads due to the motion of the ship in all loading conditions;

.6.1.4 thermal loads;

.6.1.5 sloshing loads;

.6.1.6 loads corresponding to ship deflections;

.6.1.7 tank and liquefied gas fuel weight with the corresponding reaction in way of supports;

.6.1.8 insulation weight;

.6.1.9 loads in way of towers and other attachments; and

.6.1.10 test loads.

.6.2 Fatigue Design Conditions – The liquefied gas fuel containment system structure and its structural components shall not fail under accumulated cyclic loading.

.6.3 Accidental Design Conditions – The liquefied gas fuel containment system shall meet each of the following accident design conditions (accidental or abnormal events), addressed in these Guidelines:

.6.3.1 Collision – The liquefied gas fuel containment system shall withstand the collision loads specified in 6.4.9.5.1 without deformation of the supports or the tank structure in way of the supports likely to endanger the tank and its supporting structure.

.6.3.2 Fire – The liquefied gas fuel containment systems shall sustain without rupture the rise in internal pressure specified in 6.7.3.1 under the fire scenarios envisaged therein.

<sup>3)</sup> Refer to [Guidance for Marine Industry \(Pt.1, Vol.AC\) Sec.2, R-34](#) or IACS Rec.034

<sup>4)</sup> North Atlantic environmental conditions refer to wave conditions. Assumed temperatures are used for determining appropriate material qualities with respect to design temperatures and is another matter not intended to be covered in 6.4.1.4

**.6.3.3** Flooded compartment causing buoyancy on tank – the anti-flotation arrangements shall sustain the upward force, specified in [6.4.9.5.2](#) and there shall be no endangering plastic deformation to the hull. Plastic deformation may occur in the fuel containment system provided it does not endanger the safe evacuation of the ship.

**.7** Measures shall be applied to ensure that scantlings required meet the structural strength provisions and are maintained throughout the design life. Measures may include, but are not limited to, material selection, coatings, corrosion additions, cathodic protection and inerting.

**.8** An inspection/survey plan for the liquefied gas fuel containment system shall be developed and approved by the BKI. The inspection/survey plan shall identify aspects to be examined and/or validated during surveys throughout the liquefied gas fuel containment system's life and, in particular, any necessary in-service survey, maintenance and testing that was assumed when selecting liquefied gas fuel containment system design parameters. The inspection/survey plan may include specific critical locations as per [6.4.12.2.8](#) or [6.4.12.2.9](#).<sup>5)</sup>

**.9** Liquefied gas fuel containment systems shall be designed, constructed and equipped to provide adequate means of access to areas that need inspection as specified in the inspection/survey plan. Liquefied gas fuel containment systems, including all associated internal equipment shall be designed and built to ensure safety during operations, inspection and maintenance.

#### **6.4.2 Liquefied gas fuel containment safety principles**

**.1** The containment systems shall be provided with a complete secondary liquid-tight barrier capable of safely containing all potential leakages through the primary barrier and, in conjunction with the thermal insulation system, of preventing lowering of the temperature of the ship structure to an unsafe level.

**.2** The size and configuration or arrangement of the secondary barrier may be reduced or omitted where an equivalent level of safety can be demonstrated in accordance with [6.4.2.3](#) to [6.4.2.5](#) as applicable.

**.3** Liquefied gas fuel containment systems for which the probability for structural failures to develop into a critical state has been determined to be extremely low but where the possibility of leakages through the primary barrier cannot be excluded, shall be equipped with a partial secondary barrier and small leak protection system capable of safely handling and disposing of the leakages (a critical state means that the crack develops into unstable condition). The arrangements shall comply with the following:

**.3.1** failure developments that can be reliably detected before reaching a critical state (e.g. by gas detection or inspection) shall have a sufficiently long development time for remedial actions to be taken; and

**.3.2** failure developments that cannot be safely detected before reaching a critical state shall have a predicted development time that is much longer than the expected lifetime of the tank.

**.4** No secondary barrier is required for liquefied gas fuel containment systems, e.g. type C independent tanks, where the probability for structural failures and leakages through the primary barrier is extremely low and can be neglected.

**.5** For independent tanks requiring full or partial secondary barrier, means for safely disposing of leakages from the tank shall be arranged.

#### **6.4.3 Secondary barriers in relation to tank types**

Secondary barriers in relation to the tank types defined in [6.4.15](#) shall be provided in accordance with the following table.

<sup>5)</sup> Shall be accordance with [Guidance for Marine Industry \(Pt.1, Vol.AC\) Sec.8, R-148](#)

Basic tank type	Secondary barrier requirements
Membrane	Complete secondary barrier
Independent Type A Type B Type C	Complete secondary barrier Partial secondary barrier No secondary barrier required

#### 6.4.4 Design of secondary barriers

The design of the secondary barrier, including spray shield if fitted, shall be such that:

- .1 it is capable of containing any envisaged leakage of liquefied gas fuel for a period of 15 days unless different criteria apply for particular voyages, taking into account the load spectrum referred to in [6.4.12.2.6](#);
- .2 physical, mechanical or operational events within the liquefied gas fuel tank that could cause failure of the primary barrier shall not impair the due function of the secondary barrier, or vice versa;
- .3 failure of a support or an attachment to the hull structure will not lead to loss of liquid tightness of both the primary and secondary barriers;
- .4 it is capable of being periodically checked for its effectiveness by means of a visual inspection or other suitable means acceptable to the BKI;
- .5 the methods required in [6.4.4.4](#) shall be approved by the BKI and shall include, as a minimum:
  - .5.1 details on the size of defect acceptable and the location within the secondary barrier, before its liquid tight effectiveness is compromised;
  - .5.2 accuracy and range of values of the proposed method for detecting defects in [.5.1](#) above;
  - .5.3 scaling factors to be used in determining the acceptance criteria if full scale model testing is not undertaken; and
  - .5.4 effects of thermal and mechanical cyclic loading on the effectiveness of the proposed test.
- .6 the secondary barrier shall fulfil its functional requirements at a static angle of heel of 30°.

#### 6.4.5 Partial secondary barriers and primary barrier small leak protection system

- .1 Partial secondary barriers as permitted in [6.4.2.3](#) shall be used with a small leak protection system and meet all the regulations in [6.4.4](#). The small leak protection system shall include means to detect a leak in the primary barrier, provision such as a spray shield to deflect any liquefied gas fuel down into the partial secondary barrier, and means to dispose of the liquid, which may be by natural evaporation.
- .2 The capacity of the partial secondary barrier shall be determined, based on the liquefied gas fuel leakage corresponding to the extent of failure resulting from the load spectrum referred to in [6.4.12.2.6](#), after the initial detection of a primary leak. Due account may be taken of liquid evaporation, rate of leakage, pumping capacity and other relevant factors.
- .3 The required liquid leakage detection may be by means of liquid sensors, or by an effective use of pressure, temperature or gas detection systems, or any combination thereof.
- .4 For independent tanks for which the geometry does not present obvious locations for leakage to collect, the partial secondary barrier shall also fulfil its functional requirements at a nominal static angle of trim.

#### 6.4.6 Supporting arrangements

- .1 The liquefied gas fuel tanks shall be supported by the hull in a manner that prevents bodily movement of the tank under the static and dynamic loads defined in 6.4.9.2 to 6.4.9.5, where applicable, while allowing contraction and expansion of the tank under temperature variations and hull deflections without undue stressing of the tank and the hull.
- .2 Anti-flotation arrangements shall be provided for independent tanks and capable of withstanding the loads defined in 6.4.9.5.2 without plastic deformation likely to endanger the hull structure.
- .3 Supports and supporting arrangements shall withstand the loads defined in 6.4.9.3.3.8 and 6.4.9.5, but these loads need not be combined with each other or with wave-induced loads.

#### 6.4.7 Associated structure and equipment

- .1 Liquefied gas fuel containment systems shall be designed for the loads imposed by associated structure and equipment. This includes pump towers, liquefied gas fuel domes, liquefied gas fuel pumps and piping, stripping pumps and piping, nitrogen piping, access hatches, ladders, piping penetrations, liquid level gauges, independent level alarm gauges, spray nozzles, and instrumentation systems (such as pressure, temperature and strain gauges).

#### 6.4.8 Thermal insulation

- .1 Thermal insulation shall be provided as required to protect the hull from temperatures below those allowable (see 6.4.13.1.1) and limit the heat flux into the tank to the levels that can be maintained by the pressure and temperature control system applied in 6.9.

#### 6.4.9 Design loads

##### .1 General

- .1.1 This section defines the design loads that shall be considered with regard to regulations in 6.4.10 to 6.4.12. This includes load categories (permanent, functional, environmental and accidental) and the description of the loads.
- .1.2 The extent to which these loads shall be considered depends on the type of tank, and is more fully detailed in the following paragraphs.
- .1.3 Tanks, together with their supporting structure and other fixtures, shall be designed taking into account relevant combinations of the loads described below.

##### .2 Permanent loads

###### .2.1 Gravity loads

The weight of tank, thermal insulation, loads caused by towers and other attachments shall be considered.

###### .2.2 Permanent external loads

Gravity loads of structures and equipment acting externally on the tank shall be considered.

##### .3 Functional loads

- .3.1 Loads arising from the operational use of the tank system shall be classified as functional loads.
- .3.2 All functional loads that are essential for ensuring the integrity of the tank system, during all design conditions, shall be considered.

.3.3 As a minimum, the effects from the following criteria, as applicable, shall be considered when establishing functional loads:

- 1) internal pressure
- 2) external pressure
- 3) thermally induced loads
- 4) vibration
- 5) interaction loads
- 6) loads associated with construction and installation
- 7) test loads
- 8) static heel loads
- 9) weight of liquefied gas fuel
- 10) sloshing
- 11) wind impact, wave impacts and green sea effect for tanks installed on open deck.

#### .3.3.1 Internal pressure

.3.3.1.1 In all cases, including 6.4.9.3.3.1.2,  $P_0$  shall not be less than MARVS.

.3.3.1.2 For liquefied gas fuel tanks where there is no temperature control and where the pressure of the liquefied gas fuel is dictated only by the ambient temperature,  $P_0$  shall not be less than the gauge vapour pressure of the liquefied gas fuel at a temperature of 45°C except as follows:

.3.3.1.2.1 Lower values of ambient temperature may be accepted by the BKI for ships operating in restricted areas. Conversely, higher values of ambient temperature may be required.

.3.3.1.2.2 For ships on voyages of restricted duration,  $P_0$  may be calculated based on the actual pressure rise during the voyage and account may be taken of any thermal insulation of the tank.

.3.3.1.3 Subject to special consideration by the BKI and to the limitations given in 6.4.15 for the various tank types, a vapour pressure  $P_h$  higher than  $P_0$  may be accepted for site specific conditions (harbour or other locations), where dynamic loads are reduced.

.3.3.1.4 Pressure used for determining the internal pressure shall be:

.3.3.1.4.1  $(P_{gd})_{max}$  is the associated liquid pressure determined using the maximum design accelerations.

.3.3.1.4.2  $(P_{gd\ site})_{max}$  is the associated liquid pressure determined using site specific accelerations

.3.3.1.4.3  $P_{eq}$  should be the greater of  $P_{eq1}$  and  $P_{eq2}$  calculated as follows:

$$P_{eq1} = P_0 + (P_{gd})_{max} \quad [\text{MPa}]$$

$$P_{eq2} = P_h + (P_{gd\ site})_{max} \quad [\text{MPa}]$$



**.3.3.1.5** The internal liquid pressures are those created by the resulting acceleration of the centre of gravity of the liquefied gas fuel due to the motions of the ship referred to in 6.4.9.4.1.1. The value of internal liquid pressure  $P_{gd}$  resulting from combined effects of gravity and dynamic accelerations shall be calculated as follows:

$$P_{gd} = \alpha_{\beta} Z_{\beta} \left( \frac{\rho}{(1.02 \times 10^5)} \right) \text{ [MPa]}$$

where:

$\alpha_{\beta}$  = dimensionless acceleration (i.e. relative to the acceleration of gravity), resulting from gravitational and dynamic loads, in an arbitrary direction  $\beta$ ; (see Figure 6.4.1).

For large tanks, an acceleration ellipsoid, taking account of transverse vertical and longitudinal accelerations, should be used.

$Z_{\beta}$  = largest liquid height (m) above the point where the pressure is to be determined measured from the tank shell in the direction (see Figure 6.4.2).

Tank domes considered to be part of the accepted total tank volume shall be taken into account when determining  $Z_{\beta}$  unless the total volume of tank domes  $V_d$  does not exceed the following value:

$$V_d = V_t \left( \frac{100 - FL}{FL} \right)$$

where:

$V_t$  = tank volume without any domes; and

FL = filling limit according to 6.8

$\rho$  = maximum liquefied gas fuel density ( $\text{kg/m}^3$ ) at the design temperature.

The direction that gives the maximum value  $(P_{gd})_{\text{max}}$  or  $(P_{gd \text{ site}})_{\text{max}}$  shall be considered. Where acceleration components in three directions need to be considered, an ellipsoid shall be used instead of the ellipse in Figure 6.4.1. The above formula applies only to full tanks.

### **.3.3.2 External pressure**

External design pressure loads shall be based on the difference between the minimum internal pressure and the maximum external pressure to which any portion of the tank may be simultaneously subjected.

### **.3.3.3 Thermally induced loads**

**.3.3.3.1** Transient thermally induced loads during cooling down periods shall be considered for tanks intended for liquefied gas fuel temperatures below minus 55°C.

**.3.3.3.2** Stationary thermally induced loads shall be considered for liquefied gas fuel containment systems where the design supporting arrangements or attachments and operating temperature may give rise to significant thermal stresses (see paragraph 6.9.2).

### **.3.3.4 Vibration**

The potentially damaging effects of vibration on the liquefied gas fuel containment system shall be considered.

### **.3.3.5 Interaction loads**

The static component of loads resulting from interaction between liquefied gas fuel containment system and the hull structure, as well as loads from associated structure and equipment, shall be considered.

### **.3.3.6 Loads associated with construction and installation**

Loads or conditions associated with construction and installation shall be considered, e.g. lifting.



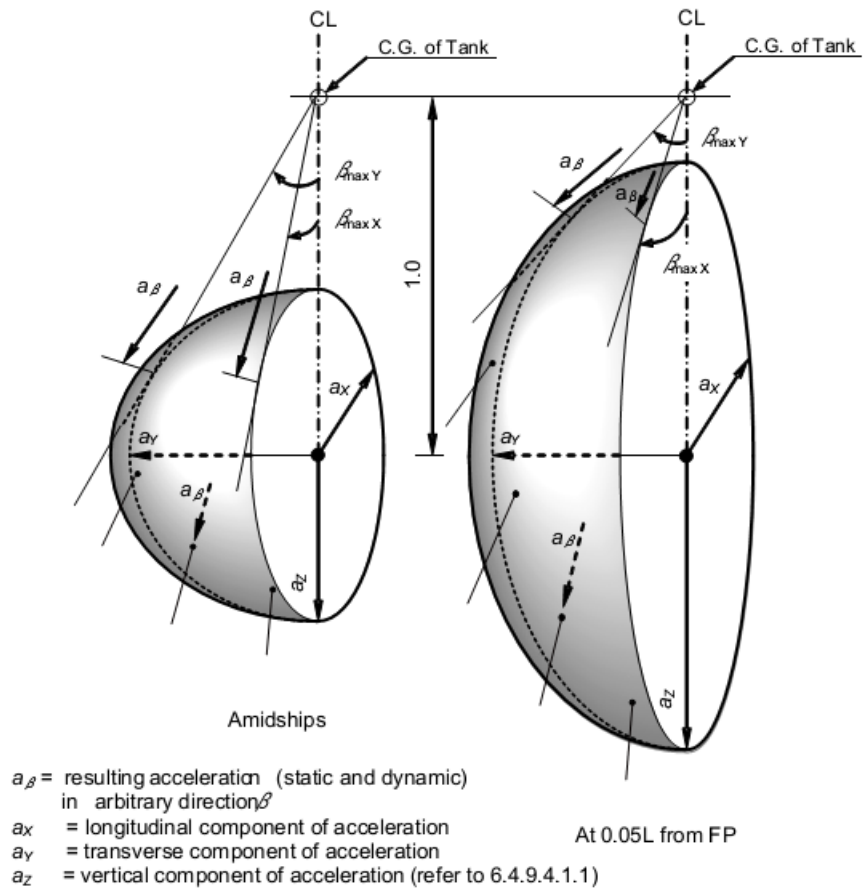

Figure 6.4.1: Acceleration Ellipsoid

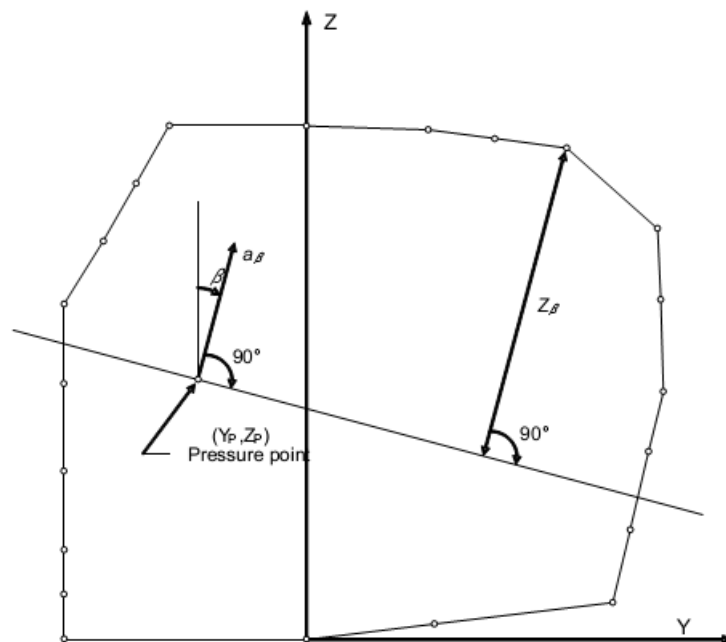

Figure 6.4.2: Determination of internal pressure heads

#### **.3.3.7 Test loads**

Account shall be taken of the loads corresponding to the testing of the liquefied gas fuel containment system referred to in 16.5.

#### **.3.3.8 Static heel loads**

Loads corresponding to the most unfavourable static heel angle within the range 0° to 30° shall be considered.

#### **.3.3.9 Other loads**

Any other loads not specifically addressed, which could have an effect on the liquefied gas fuel containment system, shall be taken into account.

### **.4 Environmental loads**

**.4.1** Environmental loads are defined as those loads on the liquefied gas fuel containment system that are caused by the surrounding environment and that are not otherwise classified as a permanent, functional or accidental load.

#### **.4.1.1 Loads due to ship motion**

The determination of dynamic loads shall take into account the long-term distribution of ship motion in irregular seas, which the ship will experience during its operating life. Account may be taken of the reduction in dynamic loads due to necessary speed reduction and variation of heading. The ship's motion shall include surge, sway, heave, roll, pitch and yaw. The accelerations acting on tanks shall be estimated at their centre of gravity and include the following components:

**.4.1.1.1** vertical acceleration: motion accelerations of heave, pitch and, possibly roll (normal to the ship base);

**.4.1.1.2** transverse acceleration: motion accelerations of sway, yaw and roll and gravity component of roll; and

**.4.1.1.3** longitudinal acceleration: motion accelerations of surge and pitch and gravity component of pitch.

Methods to predict accelerations due to ship motion shall be proposed and approved by the BKI <sup>6)</sup>

Ships for restricted service may be given special consideration.

#### **.4.1.2 Dynamic interaction loads**

Account shall be taken of the dynamic component of loads resulting from interaction between liquefied gas fuel containment systems and the hull structure, including loads from associated structures and equipment.

**.4.1.3 Sloshing loads** The sloshing loads on a liquefied gas fuel containment system and internal components shall be evaluated for the full range of intended filling levels.

#### **.4.1.4 Snow and ice loads**

Snow and icing shall be considered, if relevant.

#### **.4.1.5 Loads due to navigation in ice**

Loads due to navigation in ice shall be considered for vessels intended for such service.

#### **.4.1.6 Green sea loading**

Account shall be taken to loads due to water on deck.

#### **.4.1.7 Wind loads**

Account shall be taken to wind generated loads as relevant.

---

<sup>6)</sup> Refer to [Rules for Ships Carrying Liquefied Gases in Bulk \(Pt.1, Vol.IX\) Sec.4.28.2.1](#) of the guidance formulae for acceleration components

## .5 Accidental loads

Accidental loads are defined as loads that are imposed on a liquefied gas fuel containment system and its supporting arrangements under abnormal and unplanned conditions.

### .5.1 Collision load

The collision load shall be determined based on the fuel containment system under fully loaded condition with an inertial force corresponding to "a" in the table below in forward direction and "a/2" in the aft direction, where "g" is gravitational acceleration.

Ship length (L)	Design acceleration (a)
L > 100 m	0,5 g
60 < L ≤ 100m	$\left(2 - \frac{3(L-60)}{80}\right) g$
L ≤ 60 m	2g

Special consideration should be given to ships with Froude number (Fn) > 0,4.

### .5.2 Loads due to flooding on ship

For independent tanks, loads caused by the buoyancy of a fully submerged empty tank shall be considered in the design of anti-flotation chocks and the supporting structure in both the adjacent hull and tank structure.

## 6.4.10 Structural integrity

### .1 General

.1.1 The structural design shall ensure that tanks have an adequate capacity to sustain all relevant loads with an adequate margin of safety. This shall take into account the possibility of plastic deformation, buckling, fatigue and loss of liquid and gas tightness.

.1.2 The structural integrity of liquefied gas fuel containment systems can be demonstrated by compliance with 6.4.15, as appropriate for the liquefied gas fuel containment system type.

.1.3 For other liquefied gas fuel containment system types, that are of novel design or differ significantly from those covered by 6.4.15, the structural integrity shall be demonstrated by compliance with 6.4.16.

## 6.4.11 Structural analysis

### .1 Analysis

.1.1 The design analyses shall be based on accepted principles of statics, dynamics and strength of materials.

.1.2 Simplified methods or simplified analyses may be used to calculate the load effects, provided that they are conservative. Model tests may be used in combination with, or instead of, theoretical calculations. In cases where theoretical methods are inadequate, model or full scale tests may be required.

.1.3 When determining responses to dynamic loads, the dynamic effect shall be taken into account where it may affect structural integrity.

**.2 Load scenarios**

**.2.1** For each location or part of the liquefied gas fuel containment system to be considered and for each possible mode of failure to be analysed, all relevant combinations of loads that may act simultaneously shall be considered.

**.2.2** The most unfavourable scenarios for all relevant phases during construction, handling, testing and in service conditions shall be considered.

**.2.3** When the static and dynamic stresses are calculated separately and unless other methods of calculation are justified, the total stresses shall be calculated according to:

$$\begin{aligned} \sigma_x &= \sigma_{x.st} \pm \sqrt{\sum (\sigma_{x.dyn})^2} \\ \sigma_y &= \sigma_{y.st} \pm \sqrt{\sum (\sigma_{y.dyn})^2} \\ \sigma_z &= \sigma_{z.st} \pm \sqrt{\sum (\sigma_{z.dyn})^2} \\ \tau_{xy} &= \tau_{xy.st} \pm \sqrt{\sum (\tau_{xy.dyn})^2} \\ \tau_{xz} &= \tau_{xz.st} \pm \sqrt{\sum (\tau_{xz.dyn})^2} \\ \tau_{yz} &= \tau_{yz.st} \pm \sqrt{\sum (\tau_{yz.dyn})^2} \end{aligned}$$

where :

$\sigma_{x.st}$ ,  $\sigma_{y.st}$ ,  $\sigma_{z.st}$ ,  $\tau_{xy.st}$ ,  $\tau_{xz.st}$ , and  $\tau_{yz.st}$  are static stresses; and

$\sigma_{x.dyn}$ ,  $\sigma_{y.dyn}$ ,  $\sigma_{z.dyn}$ ,  $\tau_{xy.dyn}$ ,  $\tau_{xz.dyn}$ , and  $\tau_{yz.dyn}$  are dynamic stresses,

each shall be determined separately from acceleration components and hull strain components due to deflection and torsion.

**6.4.12 Design conditions**

All relevant failure modes shall be considered in the design for all relevant load scenarios and design conditions. The design conditions are given in the earlier part of this section, and the load scenarios are covered by 6.4.11.2.

**.1 Ultimate design condition**

**.1.1** Structural capacity may be determined by testing, or by analysis, taking into account both the elastic and plastic material properties, by simplified linear elastic analysis or by the provisions of these Guidelines:

**.1.1.1** Plastic deformation and buckling shall be considered.

**.1.1.2** Analysis shall be based on characteristic load values as follows:

Permanent loads	Expected values
Functional loads	Specified values
Environmental loads	For wave loads: most probable largest load encountered during 10 <sup>8</sup> wave encounters.

.1.1.3 For the purpose of ultimate strength assessment the following material parameters apply:

.1.1.3.1  $R_e$  = specified minimum yield stress at room temperature [N/mm<sup>2</sup>]. If the stress-strain curve does not show a defined yield stress, the 0,2

.1.1.3.2  $R_m$  = specified minimum tensile strength at room temperature [N/mm<sup>2</sup>].

For welded connections where under-matched welds, i.e. where the weld metal has lower tensile strength than the parent metal, are unavoidable, such as in some aluminium alloys, the respective  $R_e$  and  $R_m$  of the welds, after any applied heat treatment, shall be used. In such cases the transverse weld tensile strength shall not be less than the actual yield strength of the parent metal. If this cannot be achieved, welded structures made from such materials shall not be incorporated in liquefied gas fuel containment systems.

The above properties shall correspond to the minimum specified mechanical properties of the material, including the weld metal in the as fabricated condition. Subject to special consideration by the BKI, account may be taken of the enhanced yield stress and tensile strength at low temperature.

.1.1.4 The equivalent stress  $\sigma_c$  (von Mises, Huber) shall be determined by :

$$\sigma_c = \sqrt{\sigma_x^2 + \sigma_y^2 + \sigma_z^2 - \sigma_x\sigma_y - \sigma_x\sigma_z - \sigma_y\sigma_z + 3(\tau_{xy}^2 + \tau_{xz}^2 + \tau_{yz}^2)}$$

where:

$\sigma_x$  = total normal stress in x-direction;

$\sigma_y$  = total normal stress in y-direction;

$\sigma_z$  = total normal stress in z-direction;

$\tau_{xy}$  = total shear stress in x-y plane;

$\tau_{xz}$  = total shear stress in x-z plane;and

$\tau_{yz}$  = total shear stress in y-z plane.

The above values shall be calculated as described in 6.4.11.2.3.

.1.1.5 Allowable stresses for materials other than those covered by 7.4 shall be subject to approval by the BKI in each case.

.1.1.6 Stresses may be further limited by fatigue analysis, crack propagation analysis and buckling criteria.

## .2 Fatigue Design Condition

.2.1 The fatigue design condition is the design condition with respect to accumulated cyclic loading.

.2.2 Where a fatigue analysis is required the cumulative effect of the fatigue load shall comply with:

$$\sum \frac{n_i}{N_i} + \frac{n_{\text{Loading}}}{N_{\text{Loading}}} \leq C_w$$

where:

$n_i$  = number of stress cycles at each stress level during the life of the tank;

$N_i$  = number of cycles to fracture for the respective stress level according to the Wohler (S-N) curve;

$n_{\text{Loading}}$  = number of loading and unloading cycles during the life of the tank not to be less than 1000. Loading and unloading cycles include a complete pressure and thermal cycle;

$N_{\text{Loading}}$  = number of cycles to fracture for the fatigue loads due to loading and unloading; and

$C_w$  = maximum allowable cumulative fatigue damage ratio.

The fatigue damage shall be based on the design life of the tank but not less than  $10^8$  wave encounters.

**.2.3** Where required, the liquefied gas fuel containment system shall be subject to fatigue analysis, considering all fatigue loads and their appropriate combinations for the expected life of the liquefied gas fuel containment system. Consideration shall be given to various filling conditions.

**.2.4** Design S-N curves used in the analysis shall be applicable to the materials and weldments, construction details, fabrication procedures and applicable state of the stress envisioned.

The S-N curves shall be based on a 97,6% probability of survival corresponding to the mean-minus-two-standard-deviation curves of relevant experimental data up to final failure. Use of S-N curves derived in a different way requires adjustments to the acceptable  $C_w$  values specified in [6.4.12.2.7](#) to [6.4.12.2.9](#).

**.2.5** Analysis shall be based on characteristic load values as follows:

Permanent loads	Expected values
Functional loads	Specified values or specified history
Environmental loads	Expected load history, but not less than $10^8$ cycles.

If simplified dynamic loading spectra are used for the estimation of the fatigue life, those shall be specially considered by the BKI.

**.2.6** Where the size of the secondary barrier is reduced, as is provided for in [6.4.2.3](#), fracture mechanics analyses of fatigue crack growth shall be carried out to determine:

**.2.6.1** crack propagation paths in the structure, where necessitated by [6.4.12.2.7](#) to [6.4.12.2.9](#), as applicable;

**.2.6.2** crack growth rate;

**.2.6.3** the time required for a crack to propagate to cause a leakage from the tank;

**.2.6.4** the size and shape of through thickness cracks; and

**.2.6.5** the time required for detectable cracks to reach a critical state after penetration through the thickness.

The fracture mechanics are in general based on crack growth data taken as a mean value plus two standard deviations of the test data. Methods for fatigue crack growth analysis and fracture mechanics shall be based on recognized standards.

In analysing crack propagation, the largest initial crack not detectable by the inspection method applied shall be assumed, taking into account the allowable non-destructive testing and visual inspection criterion as applicable.

Crack propagation analysis specified in [6.4.12.2.7](#) the simplified load distribution and sequence over a period of 15 days may be used. Such distributions may be obtained as indicated in [Figure 6.4.3](#). Load distribution and sequence for longer periods, such as in [6.4.12.2.8](#) and [6.4.12.2.9](#) shall be approved by the BKI.

The arrangements shall comply with [6.4.12.2.7](#) to [6.4.12.2.9](#) as applicable.

**.2.7** For failures that can be reliably detected by means of leakage detection:

$C_w$  shall be less than or equal to 0,5.

Predicted remaining failure development time, from the point of detection of leakage till reaching a critical state, shall not be less than 15 days unless different regulations apply for ships engaged in particular voyages.

**.2.8** For failures that cannot be detected by leakage but that can be reliably detected at the time of in-service inspections:

$C_w$  shall be less than or equal to 0,5.

Predicted remaining failure development time, from the largest crack not detectable by in-service inspection methods until reaching a critical state, shall not be less than three (3) times the inspection interval.

**.2.9** In particular locations of the tank where effective defect or crack development detection cannot be assured, the following, more stringent, fatigue acceptance criteria shall be applied as a minimum:

$C_w$  shall be less than or equal to 0,1.

Predicted failure development time, from the assumed initial defect until reaching a critical state, shall not be less than three (3) times the lifetime of the tank.

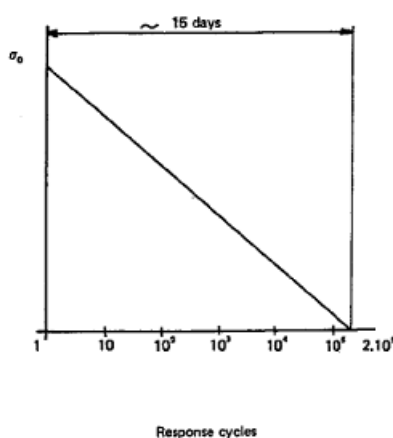

$\sigma_0$  = most probable maximum stress over the life of the ship  
 Response cycle scale is logarithmic; the value of  $2.10^6$  is given as an example of estimate.

**Figure 6.4.3: Simplified load distribution**

**.3 Accidental design condition**

**.3.1** The accidental design condition is a design condition for accidental loads with extremely low probability of occurrence.

**.3.2** Analysis shall be based on the characteristic values as follows:

Permanent loads	Expected values
Functional loads	Specified values
Environmental loads	Specified values
Accidental loads	Specified values or expected values

Loads mentioned in 6.4.9.3.3.8 and 6.4.9.5 need not be combined with each other or with wave-induced loads.

### 6.4.13 Materials and construction

#### .1 Materials

##### .1.1 Materials forming ship structure

**.1.1.1** To determine the grade of plate and sections used in the hull structure, a temperature calculation shall be performed for all tank types. The following assumptions shall be made in this calculation:

**.1.1.1.1** The primary barrier of all tanks shall be assumed to be at the liquefied gas fuel temperature.

**.1.1.1.2** In addition to [.1.1.1.1](#) above, where a complete or partial secondary barrier is required it shall be assumed to be at the liquefied gas fuel temperature at atmospheric pressure for any one tank only.

**.1.1.1.3** For worldwide service, ambient temperatures shall be taken as 5°C for air and 0°C for seawater. Higher values may be accepted for ships operating in restricted areas and conversely, lower values may be imposed by the BKI for ships trading to areas where lower temperatures are expected during the winter months.

**.1.1.1.4** Still air and sea water conditions shall be assumed, i.e. no adjustment for forced convection.

**.1.1.1.5** Degradation of the thermal insulation properties over the life of the ship due to factors such as thermal and mechanical ageing, compaction, ship motions and tank vibrations as defined in [6.4.13.3.6](#) and [6.4.13.3.7](#) shall be assumed.

**.1.1.1.6** The cooling effect of the rising boil-off vapour from the leaked liquefied gas fuel shall be taken into account where applicable.

**.1.1.1.7** Credit for hull heating may be taken in accordance with [6.4.13.1.1.3](#), provided the heating arrangements are in compliance with [6.4.13.1.1.4](#).

**.1.1.1.8** No credit shall be given for any means of heating, except as described in [6.4.13.1.1.3](#).

**.1.1.1.9** For members connecting inner and outer hulls, the mean temperature may be taken for determining the steel grade.

**.1.1.2** The materials of all hull structures for which the calculated temperature in the design condition is below 0°C, due to the influence of liquefied gas fuel temperature, shall be in accordance with [Table 7.5](#). This includes hull structure supporting the liquefied gas fuel tanks, inner bottom plating, longitudinal bulkhead plating, transverse bulkhead plating, floors, webs, stringers and all attached stiffening members.

**.1.1.3** Means of heating structural materials may be used to ensure that the material temperature does not fall below the minimum allowed for the grade of material specified in [Table 7.5](#). In the calculations required in [6.4.13.1.1.1](#), credit for such heating may be taken in accordance with the following principles:

**.1.1.3.1** for any transverse hull structure;

**.1.1.3.2** for longitudinal hull structure referred to in [6.4.13.1.1.2](#) where colder ambient temperatures are specified, provided the material remains suitable for the ambient temperature conditions of plus 5°C for air and 0°C for seawater with no credit taken in the calculations for heating; and

**.1.1.3.3** as an alternative to [6.4.13.1.1.3.2](#), for longitudinal bulkhead between liquefied gas fuel tanks, credit may be taken for heating provided the material remain suitable for a minimum design temperature of minus 30°C, or a temperature 30°C lower than that determined by [6.4.13.1.1.1](#) with the heating considered, whichever is less. In this case, the ship's longitudinal strength shall comply with SOLAS regulation II-1/3-1 for both when those bulkhead(s) are considered effective and not.

**.1.1.4** The means of heating referred to in [6.4.13.1.1.3](#) shall comply with the following:

**.1.1.4.1** the heating system shall be arranged so that, in the event of failure in any part of the system, standby heating can be maintained equal to no less than 100% of the theoretical heat requirement;

**.1.1.4.2** the heating system shall be considered as an essential auxiliary. All electrical components of at least one of the systems provided in accordance with [6.4.13.1.1.3.1](#) shall be supplied from the emergency source of electrical power; and



.1.1.4.3 the design and construction of the heating system shall be included in the approval of the containment system by the BKI.

## .2 Materials of primary and secondary barriers

.2.1 Metallic materials used in the construction of primary and secondary barriers not forming the hull, shall be suitable for the design loads that they may be subjected to, and be in accordance with [Table 7.1](#), [7.2](#) or [7.3](#).

.2.2 Materials, either non-metallic or metallic but not covered by [Table 7.1](#), [7.2](#) or [7.3](#), used in the primary and secondary barriers may be approved by the BKI considering the design loads that they may be subjected to, their properties and their intended use.

.2.3 Where non-metallic materials <sup>7)</sup>, including composites, are used for or incorporated in the primary or secondary barriers, they shall be tested for the following properties, as applicable, to ensure that they are adequate for the intended service:

.2.3.1 compatibility with the liquefied gas fuels;

.2.3.2 ageing;

.2.3.3 mechanical properties;

.2.3.4 thermal expansion and contraction;

.2.3.5 abrasion;

.2.3.6 cohesion;

.2.3.7 resistance to vibrations;

.2.3.8 resistance to fire and flame spread; and

.2.3.9 resistance to fatigue failure and crack propagation.

.2.4 The above properties, where applicable, shall be tested for the range between the expected maximum temperature in service and 5°C below the minimum design temperature, but not lower than minus 196°C.

.2.5 Where non-metallic materials, including composites, are used for the primary and secondary barriers, the joining processes shall also be tested as described above.

.2.6 Consideration may be given to the use of materials in the primary and secondary barrier, which are not resistant to fire and flame spread, provided they are protected by a suitable system such as a permanent inert gas environment, or are provided with a fire retardant barrier.

## .3 Thermal insulation and other materials used in liquefied gas fuel containment systems

.3.1 Load-bearing thermal insulation and other materials used in liquefied gas fuel containment systems shall be suitable for the design loads.

.3.2 Thermal insulation and other materials used in liquefied gas fuel containment systems shall have the following properties, as applicable, to ensure that they are adequate for the intended service:

.3.2.1 compatibility with the liquefied gas fuels;

.3.2.2 solubility in the liquefied gas fuel;

.3.2.3 absorption of the liquefied gas fuel;

.3.2.4 shrinkage;

.3.2.5 ageing;

.3.2.6 closed cell content;

---

<sup>7)</sup> Refer to Section [6.4.16](#)

- .3.2.7 density;
  - .3.2.8 mechanical properties, to the extent that they are subjected to liquefied gas fuel and other loading effects, thermal expansion and contraction;
  - .3.2.9 abrasion;
  - .3.2.10 cohesion;
  - .3.2.11 thermal conductivity;
  - .3.2.12 resistance to vibrations;
  - .3.2.13 resistance to fire and flame spread; and
  - .3.2.14 resistance to fatigue failure and crack propagation.
- .3.3 The above properties, where applicable, shall be tested for the range between the expected maximum temperature in service and 5°C below the minimum design temperature, but not lower than minus 196°C.
- .3.4 Due to location or environmental conditions, thermal insulation materials shall have suitable properties of resistance to fire and flame spread and shall be adequately protected against penetration of water vapour and mechanical damage. Where the thermal insulation is located on or above the exposed deck, and in way of tank cover penetrations, it shall have suitable fire resistance properties in accordance with a recognized standard or be covered with a material having low flame spread characteristics and forming an efficient approved vapour seal.
- .3.5 Thermal insulation that does not meet recognized standards for fire resistance may be used in fuel storage hold spaces that are not kept permanently inerted, provided its surfaces are covered with material with low flame spread characteristics and that forms an efficient approved vapour seal.
- .3.6 Testing for thermal conductivity of thermal insulation shall be carried out on suitably aged samples.
- .3.7 Where powder or granulated thermal insulation is used, measures shall be taken to reduce compaction in service and to maintain the required thermal conductivity and also prevent any undue increase of pressure on the liquefied gas fuel containment system.

#### 6.4.14 Construction processes

##### .1 Weld joint design

- .1.1 All welded joints of the shells of independent tanks shall be of the in-plane butt weld full penetration type. For dome-to-shell connections only, tee welds of the full penetration type may be used depending on the results of the tests carried out at the approval of the welding procedure. Except for small penetrations on domes, nozzle welds are also to be designed with full penetration.
- .1.2 Welding joint details for type C independent tanks, and for the liquid-tight primary barriers of type B independent tanks primarily constructed of curved surfaces, shall be as follows:
- .1.2.1 All longitudinal and circumferential joints shall be of butt welded, full penetration, double vee or single vee type. Full penetration butt welds shall be obtained by double welding or by the use of backing rings. If used, backing rings shall be removed except from very small process pressure vessels <sup>8)</sup>. Other edge preparations may be permitted, depending on the results of the tests carried out at the approval of the welding procedure. For connections of tank shell to a longitudinal bulkhead of type C bilobe tanks, tee welds of the full penetration type may be accepted.
  - .1.2.2 The bevel preparation of the joints between the tank body and domes and between domes and relevant fittings shall be designed according to a standard acceptable to the BKI. All welds connecting nozzles, domes or other penetrations of the vessel and all welds connecting flanges to the vessel or nozzles shall be full penetration welds.

<sup>8)</sup> For vacuum insulated tanks without manhole, the longitudinal and circumferential joints should meet the aforementioned requirements, except for the erection weld joint of the outer shell, which may be a one-side welding with backing rings.

## **.2 Design for gluing and other joining processes**

**.2.1** The design of the joint to be glued (or joined by some other process except welding) shall take account of the strength characteristics of the joining process.

### **6.4.15 Tank types**

#### **.1 Type A independent tanks**

##### **.1.1 Design basis**

**.1.1.1** Type A independent tanks are tanks primarily designed using classical ship-structural analysis procedures in accordance with the requirements of the BKI. Where such tanks are primarily constructed of plane surfaces, the design vapour pressure  $P_0$  shall be less than 0,07 MPa.

**.1.1.2** A complete secondary barrier is required as defined in 6.4.3. The secondary barrier shall be designed in accordance with 6.4.4.

##### **.1.2 Structural analysis**

**.1.2.1** A structural analysis shall be performed taking into account the internal pressure as indicated in 6.4.9.3.3.1, and the interaction loads with the supporting and keying system as well as a reasonable part of the ship's hull.

**.1.2.2** For parts, such as structure in way of supports, not otherwise covered by the regulations in these guidelines, stresses shall be determined by direct calculations, taking into account the loads referred to in 6.4.9.2 to 6.4.9.5 as far as applicable, and the ship deflection in way of supports.

**.1.2.3** The tanks with supports shall be designed for the accidental loads specified in 6.4.9.5. These loads need not be combined with each other or with environmental loads.

##### **.1.3 Ultimate design condition**

**.1.3.1** For tanks primarily constructed of plane surfaces, the nominal membrane stresses for primary and secondary members (stiffeners, web frames, stringers, girders), when calculated by classical analysis procedures, shall not exceed the lower of  $R_m/2,66$  or  $R_e/1,33$  for nickel steels, carbon-manganese steels, austenitic steels and aluminium alloys, where  $R_m$  and  $R_e$  are defined in 6.4.12.1.1.3. However, if detailed calculations are carried out for the primary members, the equivalent stress  $\sigma_c$ , as defined in 6.4.12.1.1.4, may be increased over that indicated above to a stress acceptable to the BKI. Calculations shall take into account the effects of bending, shear, axial and torsional deformation as well as the hull/liquefied gas fuel tank interaction forces due to the deflection of the hull structure and liquefied gas fuel tank bottoms.

**.1.3.2** Tank boundary scantlings shall meet at least the requirements of the BKI for deep tanks taking into account the internal pressure as indicated in 6.4.9.3.3.1 and any corrosion allowance required by 6.4.1.7.

**.1.3.3** The liquefied gas fuel tank structure shall be reviewed against potential buckling.

##### **.1.4 Accidental design condition**

**.1.4.1** The tanks and the tank supports shall be designed for the accidental loads and design conditions specified in 6.4.9.5 and 6.4.1.6.3 as relevant.

**.1.4.2** When subjected to the accidental loads specified in 6.4.9.5, the stress shall comply with the acceptance criteria specified in 6.4.15.1.3, modified as appropriate taking into account their lower probability of occurrence.

## .2 Type B independent tanks

### .2.1 Design basis

.2.1.1 Type B independent tanks are tanks designed using model tests, refined analytical tools and analysis methods to determine stress levels, fatigue life and crack propagation characteristics. Where such tanks are primarily constructed of plane surfaces (prismatic tanks) the design vapour pressure  $P_0$  shall be less than 0,07 MPa.

.2.1.2 A partial secondary barrier with a protection system is required as defined in 6.4.3. The small leak protection system shall be designed according to 6.4.5.

### .2.2 Structural analysis

.2.2.1 The effects of all dynamic and static loads shall be used to determine the suitability of the structure with respect to:

.2.2.1.1 plastic deformation;

.2.2.1.2 buckling;

.2.2.1.3 fatigue failure; and

.2.2.1.4 crack propagation.

Finite element analysis or similar methods and fracture mechanics analysis or an equivalent approach, shall be carried out.

.2.2.2 A three-dimensional analysis shall be carried out to evaluate the stress levels, including interaction with the ship's hull. The model for this analysis shall include the liquefied gas fuel tank with its supporting and keying system, as well as a reasonable part of the hull.

.2.2.3 A complete analysis of the particular ship accelerations and motions in irregular waves, and of the response of the ship and its liquefied gas fuel tanks to these forces and motions, shall be performed unless the data is available from similar ships.

### .2.3 Ultimate design condition

#### .2.3.1 Plastic deformation

For type B independent tanks, primarily constructed of bodies of revolution, the allowable stresses shall not exceed:

$$\begin{aligned}\sigma_m &\leq f \\ \sigma_L &\leq 1,5f \\ \sigma_b &\leq 1,5F \\ \sigma_L + \sigma_b &\leq 1,5F \\ \sigma_m + \sigma_b &\leq 1,5F \\ \sigma_m + \sigma_b + \sigma_g &\leq 3,0F \\ \sigma_L + \sigma_b + \sigma_g &\leq 3,0F\end{aligned}$$

where:

- $\sigma_m$  = equivalent primary general membrane stress;
- $\sigma_L$  = equivalent primary local membrane stress;
- $\sigma_b$  = equivalent primary bending stress;
- $\sigma_g$  = equivalent secondary stress;
- f = the lesser of  $(R_m/A)$  or  $(R_e/B)$ ; and
- F = the lesser of  $(R_m/C)$  or  $(R_e/D)$ ,

with  $R_m$  and  $R_e$  as defined in 6.4.12.1.1.3. With regard to the stresses  $\sigma_m$ ,  $\sigma_L$ ,  $\sigma_g$  and  $\sigma_b$  see also the definition of stress categories in 6.4.15.2.3.6.

The values A and B shall have at least the following minimum values:

	Nickel steels & carbon manganese steels	Austenitic steel	Alluminium alloys
A	3	3,5	4
B	2	1,6	1,5
C	3	3	3
D	1,5	1,5	1,5

The above figures may be altered considering the design condition considered in acceptance with the BKI. For type B independent tanks, primarily constructed of plane surfaces, the allowable membrane equivalent stresses applied for finite element analysis shall not exceed:

- .2.3.1.1 for nickel steels and carbon-manganese steels, the lesser of  $R_m/2$  or  $R_e/1,2$ ;
- .2.3.1.2 for austenitic steels, the lesser of  $R_m/2,5$  or  $R_e/1,2$ ; and
- .2.3.1.3 for aluminium alloys, the lesser of  $R_m/2,5$  or  $R_e/1,2$ .

The above figures may be amended considering the locality of the stress, stress analysis methods and design condition considered in acceptance with the BKI.

The thickness of the skin plate and the size of the stiffener shall not be less than those required for type A independent tanks.

### .2.3.2 Buckling

Buckling strength analyses of liquefied gas fuel tanks subject to external pressure and other loads causing compressive stresses shall be carried out in accordance with recognized standards. The method shall adequately account for the difference in theoretical and actual buckling stress as a result of plate edge misalignment, lack of straightness or flatness, ovality and deviation from true circular form over a specified arc or chord length, as applicable.

### .2.3.3 Fatigue design condition

- .2.3.3.1 Fatigue and crack propagation assessment shall be performed in accordance with the provisions of 6.4.12.2. The acceptance criteria shall comply with 6.4.12.2.7, 6.4.12.2.8 or 6.4.12.2.9, depending on the detectability of the defect.
- .2.3.3.2 Fatigue analysis shall consider construction tolerances.
- .2.3.3.3 Where deemed necessary by the BKI, model tests may be required to determine stress concentration factors and fatigue life of structural elements.

#### .2.3.4 Accidental design condition

.2.3.4.1 The tanks and the tank supports shall be designed for the accidental loads and design conditions specified in 6.4.9.5 and 6.4.1.6.3, as relevant.

.2.3.4.2 When subjected to the accidental loads specified in 6.4.9.5, the stress shall comply with the acceptance criteria specified in 6.4.15.2.3, modified as appropriate, taking into account their lower probability of occurrence.

#### .2.3.5 Marking

Any marking of the pressure vessel shall be achieved by a method that does not cause unacceptable local stress raisers.

#### .2.3.6 Stress categories

For the purpose of stress evaluation, stress categories are defined in this section as follows:

.2.3.6.1 Normal stress is the component of stress normal to the plane of reference.

.2.3.6.2 Membrane stress is the component of normal stress that is uniformly distributed and equal to the average value of the stress across the thickness of the section under consideration.

.2.3.6.3 Bending stress is the variable stress across the thickness of the section under consideration, after the subtraction of the membrane stress.

.2.3.6.4 Shear stress is the component of the stress acting in the plane of reference.

.2.3.6.5 Primary stress is a stress produced by the imposed loading, which is necessary to balance the external forces and moments. The basic characteristic of a primary stress is that it is not self-limiting. Primary stresses that considerably exceed the yield strength will result in failure or at least in gross deformations.

.2.3.6.6 Primary general membrane stress is a primary membrane stress that is so distributed in the structure that no redistribution of load occurs as a result of yielding.

.2.3.6.7 Primary local membrane stress arises where a membrane stress produced by pressure or other mechanical loading and associated with a primary or a discontinuity effect produces excessive distortion in the transfer of loads for other portions of the structure. Such a stress is classified as a primary local membrane stress, although it has some characteristics of a secondary stress. A stress region may be considered as local, if:

$$S_1 \leq 0,5\sqrt{Rt} \quad \text{and} \\ S_2 \geq 2,5\sqrt{Rt}$$

where:

- $S_1$  = distance in the meridional direction over which the equivalent stress exceeds  $1,1f$ ;
- $S_2$  = distance in the meridional direction to another region where the limits for primary general membrane stress are exceeded;
- $R$  = mean radius of the vessel;
- $t$  = wall thickness of the vessel at the location where the primary general membrane stress limit is exceeded; and
- $f$  = allowable primary general membrane stress.

**.2.3.6.8** Secondary stress is a normal stress or shear stress developed by constraints of adjacent parts or by self-constraint of a structure. The basic characteristic of a secondary stress is that it is self-limiting. Local yielding and minor distortions can satisfy the conditions that cause the stress to occur.

### **.3 Type C independent tanks**

#### **.3.1 Design basis**

**.3.1.1** The design basis for type C independent tanks is based on pressure vessel criteria modified to include fracture mechanics and crack propagation criteria. The minimum design pressure defined in [6.4.15.3.1.2](#) is intended to ensure that the dynamic stress is sufficiently low so that an initial surface flaw will not propagate more than half the thickness of the shell during the lifetime of the tank.

**.3.1.2** The design vapour pressure shall not be less than:

$$P_0 = 0,2 + AC(\rho_r)^{1,5} \quad [\text{MPa}]$$

where:

$$A = 0,00185 \left( \frac{\sigma_m}{\Delta\sigma_A} \right)^2$$

with:

$\sigma_m$  = design primary membrane stress;

$\Delta\sigma_A$  = allowable dynamic membrane stress (double amplitude at probability level  $Q = 10^{-8}$ ) and equal to:

= 55 N/mm<sup>2</sup> for ferritic-perlitic, martensitic and austenitic steel;

= 25 N/mm<sup>2</sup> for aluminium alloy (5083-O);

C = a characteristic tank dimension to be taken as the greatest of the following:

h, 0,75b or 0,45ℓ

with:

h = height of tank (dimension in ship's vertical direction) (m);

b = width of tank (dimension in ship's transverse direction) (m);

ℓ = length of tank (dimension in ship's longitudinal direction) (m);

$\rho_r$  = the relative density of the cargo ( $\rho_r = 1$  for fresh water) at the design temperature.

#### **.3.2 Shell thickness**

**.3.2.1** In considering the shell thickness the following apply:

**.3.2.1.1** for pressure vessels, the thickness calculated according to [6.4.15.3.2.4](#) shall be considered as a minimum thickness after forming, without any negative tolerance;

**.3.2.1.2** for pressure vessels, the minimum thickness of shell and heads including corrosion allowance, after forming, shall not be less than 5 mm for carbon manganese steels and nickel steels, 3 mm for austenitic steels or 7 mm for aluminium alloys; and

**.3.2.1.3** the welded joint efficiency factor to be used in the calculation according to [6.4.15.3.2.4](#) shall be 0,95 when the inspection and the non-destructive testing referred to in [16.3.6.4](#) are carried out. This figure may be increased up to 1,0 when account is taken of other considerations, such as the material used, type of joints, welding procedure and type of loading. For process pressure vessels the BKI may accept partial non-destructive examinations, but not less than those of [16.3.6.4](#), depending on such factors as the material used, the design temperature, the nil ductility transition temperature of the material as fabricated and the type of joint and welding procedure, but in this case an efficiency factor of not more than 0,85 shall be adopted. For special materials the above-mentioned factors shall be reduced, depending on the specified mechanical properties of the welded joint.

**.3.2.2** The design liquid pressure defined in [6.4.9.3.3.1](#) shall be taken into account in the internal pressure calculations.

**.3.2.3** The design external pressure  $P_e$ , used for verifying the buckling of the pressure vessels, shall not be less than that given by:

$$P_e = P_1 + P_2 + P_3 + P_4 \quad [\text{MPa}]$$

where:

- $P_1$  = setting value of vacuum relief valves. For vessels not fitted with vacuum relief valves  $P_1$  shall be specially considered, but shall not in general be taken as less than 0,025 MPa.
- $P_2$  = the set pressure of the pressure relief valves (PRVs) for completely closed spaces containing pressure vessels or parts of pressure vessels; elsewhere  $P_2 = 0$ .
- $P_3$  = compressive actions in or on the shell due to the weight and contraction of thermal insulation, weight of shell including corrosion allowance and other miscellaneous external pressure loads to which the pressure vessel may be subjected. These include, but are not limited to, weight of domes, weight of towers and piping, effect of product in the partially filled condition, accelerations and hull deflection. In addition, the local effect of external or internal pressures or both shall be taken into account.
- $P_4$  = external pressure due to head of water for pressure vessels or part of pressure vessels on exposed decks; elsewhere  $P_4 = 0$ .

**.3.2.4** Scantlings based on internal pressure shall be calculated as follows:

The thickness and form of pressure-containing parts of pressure vessels, under internal pressure, as defined in [6.4.9.3.3.1](#), including flanges, shall be determined. These calculations shall in all cases be based on accepted pressure vessel design theory. Openings in pressure-containing parts of pressure vessels shall be reinforced in accordance with a recognized standard acceptable to the BKI.

**.3.2.5** Stress analysis in respect of static and dynamic loads shall be performed as follows:

**.3.2.5.1** pressure vessel scantlings shall be determined in accordance with [6.4.15.3.2.1](#) to [6.4.15.3.2.4](#) and [6.4.15.3.3](#);

**.3.2.5.2** calculations of the loads and stresses in way of the supports and the shell attachment of the support shall be made. Loads referred to in [6.4.9.2](#) to [6.4.9.5](#) shall be used, as applicable. Stresses in way of the supports shall be to a recognized standard acceptable to the BKI. In special cases a fatigue analysis may be required by the BKI; and

**.3.2.5.3** if required by the BKI, secondary stresses and thermal stresses shall be specially considered.



### .3.3 Ultimate design condition

**.3.3.1 Plastic deformation** For type C independent tanks, the allowable stresses shall not exceed:

$$\begin{aligned} \sigma_m &\leq f \\ \sigma_L &\leq 1,5f \\ \sigma_b &\leq 1,5f \\ \sigma_L + \sigma_b &\leq 1,5f \\ \sigma_m + \sigma_b &\leq 1,5f \\ \sigma_m + \sigma_b + \sigma_g &\leq 3,0f \\ \sigma_L + \sigma_b + \sigma_g &\leq 3,0f \end{aligned}$$

where:

- $\sigma_m$  = equivalent primary general membrane stress;
- $\sigma_L$  = equivalent primary local membrane stress;
- $\sigma_b$  = equivalent primary bending stress;
- $\sigma_g$  = equivalent secondary stress;
- f = the lesser of  $(R_m/A)$  or  $(R_e/B)$ ; and

with  $R_m$  and  $R_e$  as defined in 6.4.12.1.1.3. With regard to the stresses  $\sigma_m$ ,  $\sigma_L$ ,  $\sigma_g$  and  $\sigma_b$  see also the definition of stress categories in 6.4.15.2.3.6. The values A and B shall have at least the following minimum values:

	Nickel steels & carbon manganese steels	Austenitic steel	Aluminium alloys
A	3	3,5	4
B	1,5	1,5	1,5

**.3.3.2 Buckling criteria** shall be as follows: The thickness and form of pressure vessels subject to external pressure and other loads causing compressive stresses shall be based on calculations using accepted pressure vessel buckling theory and shall adequately account for the difference in theoretical and actual buckling stress as a result of plate edge misalignment, ovality and deviation from true circular form over a specified arc or chord length.

### .3.4 Fatigue design condition

**.3.4.1** For type C independent tanks where the liquefied gas fuel at atmospheric pressure is below minus 55°C, the BKI may require additional verification to check their compliance with 6.4.15.3.1.1, regarding static and dynamic stress depending on the tank size, the configuration of the tank and arrangement of its supports and attachments.

**.3.4.2** For vacuum insulated tanks special attention shall be made to the fatigue strength of the support design and special considerations shall also be made to the limited inspection possibilities between the inside and outer shell.

### .3.5 Accidental design condition

**.3.5.1** The tanks and the tank supports shall be designed for the accidental loads and design conditions specified in 6.4.9.5 and 6.4.1.6.3, as relevant.

.3.5.2 When subjected to the accidental loads specified in 6.4.9.5, the stress shall comply with the acceptance criteria specified in 6.4.15.3.3.1, modified as appropriate taking into account their lower probability of occurrence.

### .3.6 Marking

The required marking of the pressure vessel shall be achieved by a method that does not cause unacceptable local stress raisers.

## .4 Membrane tanks

### .4.1 Design basis

.4.1.1 The design basis for membrane containment systems is that thermal and other expansion or contraction is compensated for without undue risk of losing the tightness of the membrane.

.4.1.2 A systematic approach, based on analysis and testing, shall be used to demonstrate that the system will provide its intended function in consideration of the identified in service events as specified in 6.4.15.4.2.1.

.4.1.3 A complete secondary barrier is required as defined in 6.4.3. The secondary barrier shall be designed according to 6.4.4.

.4.1.4 The design vapour pressure  $P_0$  shall not normally exceed 0,025 MPa. If the hull scantlings are increased accordingly and consideration is given, where appropriate, to the strength of the supporting thermal insulation,  $P_0$  may be increased to a higher value but less than 0,070 MPa.

.4.1.5 The definition of membrane tanks does not exclude designs such as those in which non-metallic membranes are used or where membranes are included or incorporated into the thermal insulation.

.4.1.6 The thickness of the membranes shall normally not exceed 10 mm.

.4.1.7 The circulation of inert gas throughout the primary and the secondary insulation spaces, in accordance with 6.11.1 shall be sufficient to allow for effective means of gas detection.

### .4.2 Design considerations

.4.2.1 Potential incidents that could lead to loss of fluid tightness over the life of the membranes shall be evaluated. These include, but are not limited to:

.4.2.1.1 Ultimate design events:

.4.2.1.1.1 tensile failure of membranes;

.4.2.1.1.2 compressive collapse of thermal insulation;

.4.2.1.1.3 thermal ageing;

.4.2.1.1.4 loss of attachment between thermal insulation and hull structure;

.4.2.1.1.5 loss of attachment of membranes to thermal insulation system;

.4.2.1.1.6 structural integrity of internal structures and their associated supporting structures; and

.4.2.1.1.7 failure of the supporting hull structure.

.4.2.1.2 Fatigue design events:

.4.2.1.2.1 fatigue of membranes including joints and attachments to hull structure;

.4.2.1.2.2 fatigue cracking of thermal insulation;

.4.2.1.2.3 fatigue of internal structures and their associated supporting structures; and

.4.2.1.2.4 fatigue cracking of inner hull leading to ballast water ingress.

**.4.2.1.3 Accident design events:**

- .4.2.1.3.1** accidental mechanical damage (such as dropped objects inside the tank while in service);
- .4.2.1.3.2** accidental over pressurization of thermal insulation spaces;
- .4.2.1.3.3** accidental vacuum in the tank; and
- .4.2.1.3.4** water ingress through the inner hull structure.

Designs where a single internal event could cause simultaneous or cascading failure of both membranes are unacceptable.

**.4.2.2** The necessary physical properties (mechanical, thermal, chemical, etc.) of the materials used in the construction of the liquefied gas fuel containment system shall be established during the design development in accordance with [6.4.15.4.1.2](#).

**.4.3 Loads, load combinations**

Particular consideration shall be paid to the possible loss of tank integrity due to either an overpressure in the interbarrier space, a possible vacuum in the liquefied gas fuel tank, the sloshing effects, to hull vibration effects, or any combination of these events.

**.4.4 Structural analyses**

**.4.4.1** Structural analyses and/or testing for the purpose of determining the ultimate strength and fatigue assessments of the liquefied gas fuel containment and associated structures and equipment noted in [6.4.7](#) shall be performed. The structural analysis shall provide the data required to assess each failure mode that has been identified as critical for the liquefied gas fuel containment system.

**.4.4.2** Structural analyses of the hull shall take into account the internal pressure as indicated in [6.4.9.3.3.1](#). Special attention shall be paid to deflections of the hull and their compatibility with the membrane and associated thermal insulation.

**.4.4.3** The analyses referred to in [6.4.15.4.4.1](#) and [6.4.15.4.4.2](#) shall be based on the particular motions, accelerations and response of ships and liquefied gas fuel containment systems.

**.4.5 Ultimate design condition**

**.4.5.1** The structural resistance of every critical component, sub-system, or assembly, shall be established, in accordance with [6.4.15.4.1.2](#), for in-service conditions.

**.4.5.2** The choice of strength acceptance criteria for the failure modes of the liquefied gas fuel containment system, its attachments to the hull structure and internal tank structures, shall reflect the consequences associated with the considered mode of failure.

**.4.5.3** The inner hull scantlings shall meet the regulations for deep tanks, taking into account the internal pressure as indicated in [6.4.9.3.3.1](#) and the specified appropriate regulations for sloshing load as defined in [6.4.9.4.1.3](#).

**.4.6 Fatigue design condition**

**.4.6.1** Fatigue analysis shall be carried out for structures inside the tank, i.e. pump towers, and for parts of membrane and pump tower attachments, where failure development cannot be reliably detected by continuous monitoring.

**.4.6.2** The fatigue calculations shall be carried out in accordance with [6.4.12.2](#), with relevant regulations depending on:

- .4.6.2.1** the significance of the structural components with respect to structural integrity; and

.4.6.2.2 availability for inspection.

.4.6.3 For structural elements for which it can be demonstrated by tests and/or analyses that a crack will not develop to cause simultaneous or cascading failure of both membranes,  $C_w$  shall be less than or equal to 0,5.

.4.6.4 Structural elements subject to periodic inspection, and where an unattended fatigue crack can develop to cause simultaneous or cascading failure of both membranes, shall satisfy the fatigue and fracture mechanics regulations stated in 6.4.12.2.8.

.4.6.5 Structural element not accessible for in-service inspection, and where a fatigue crack can develop without warning to cause simultaneous or cascading failure of both membranes, shall satisfy the fatigue and fracture mechanics regulations stated in 6.4.12.2.9.

#### .4.7 Accidental design condition

.4.7.1 The containment system and the supporting hull structure shall be designed for the accidental loads specified in 6.4.9.5. These loads need not be combined with each other or with environmental loads.

.4.7.2 Additional relevant accidental scenarios shall be determined based on a risk analysis. Particular attention shall be paid to securing devices inside of tanks.

#### 6.4.16 Limit state design for novel concepts

.1 Fuel containment systems that are of a novel configuration that cannot be designed using section 6.4.15 shall be designed using this section and 6.4.1 to 6.4.14, as applicable. Fuel containment system design according to this section shall be based on the principles of limit state design which is an approach to structural design that can be applied to established design solutions as well as novel designs. This more generic approach maintains a level of safety similar to that achieved for known containment systems as designed using 6.4.15.

.2 The limit state design is a systematic approach where each structural element is evaluated with respect to possible failure modes related to the design conditions identified in 6.4.1.6. A limit state can be defined as a condition beyond which the structure, or part of a structure, no longer satisfies the regulations.

.3 For each failure mode, one or more limit states may be relevant. By consideration of all relevant limit states, the limit load for the structural element is found as the minimum limit load resulting from all the relevant limit states. The limit states are divided into the three following categories:

.3.1 Ultimate limit states (ULS), which correspond to the maximum load-carrying capacity or, in some cases, to the maximum applicable strain or deformation; under intact (undamaged) conditions.

.3.2 Fatigue limit states (FLS), which correspond to degradation due to the effect of time varying (cyclic) loading.

.3.3 Accident limit states (ALS), which concern the ability of the structure to resist accidental situations.

.4 The procedure and relevant design parameters of the limit state design shall comply with the Standards for the Use of limit state methodologies in the design of fuel containment systems of novel configuration (LSD Standard), as set out in the Annex A.

#### 6.5 Portable liquefied gas fuel tanks

6.5.1 The design of the tank shall comply with 6.4.15.3. The tank support (container frame or truck chassis) shall be designed for the intended purpose.

6.5.2 Portable fuel tanks shall be located in dedicated areas fitted with:

- .1 mechanical protection of the tanks depending on location and cargo operations;
- .2 if located on open deck: spill protection and water spray systems for cooling; and

.3 if located in an enclosed space: the space is to be considered as a tank connection space.

**6.5.3** Portable fuel tanks shall be secured to the deck while connected to the ship systems. The arrangement for supporting and fixing the tanks shall be designed for the maximum expected static and dynamic inclinations, as well as the maximum expected values of acceleration, taking into account the ship characteristics and the position of the tanks.

**6.5.4** Consideration shall be given to the strength and the effect of the portable fuel tanks on the ship's stability.

**6.5.5** Connections to the ship's fuel piping systems shall be made by means of approved flexible hoses or other suitable means designed to provide sufficient flexibility.

**6.5.6** Arrangements shall be provided to limit the quantity of fuel spilled in case of inadvertent disconnection or rupture of the non-permanent connections.

**6.5.7** The pressure relief system of portable tanks shall be connected to a fixed venting system.

**6.5.8** Control and monitoring systems for portable fuel tanks shall be integrated in the ship's control and monitoring system. Safety system for portable fuel tanks shall be integrated in the ship's safety system (e.g. shut-down systems for tank valves, leak/gas detection systems).

**6.5.9** Safe access to tank connections for the purpose of inspection and maintenance shall be ensured.

**6.5.10** After connection to the ship's fuel piping system,

.1 with the exception of the pressure relief system in 6.5.6 each portable tank shall be capable of being isolated at any time;

.2 isolation of one tank shall not impair the availability of the remaining portable tanks; and

.3 the tank shall not exceed its filling limits as given in 6.8.

## 6.6 CNG fuel containment

**6.6.1** The storage tanks to be used for CNG shall be certified and approved by the BKI.

**6.6.2** Tanks for CNG shall be fitted with pressure relief valves with a set point below the design pressure of the tank and with outlet located as required in 6.7.2.7 and 6.7.2.8.

**6.6.3** Adequate means shall be provided to depressurize the tank in case of a fire which can affect the tank.

**6.6.4** Storage of CNG in enclosed spaces is normally not acceptable, but may be permitted after special consideration and approval by the BKI provided the following is fulfilled in addition to 6.3.4 to 6.3.6:

.1 adequate means are provided to depressurize and inert the tank in case of a fire which can affect the tank;

.2 all surfaces within such enclosed spaces containing the CNG storage are provided with suitable thermal protection against any lost high-pressure gas and resulting condensation unless the bulkheads are designed for the lowest temperature that can arise from gas expansion leakage; and

.3 a fixed fire-extinguishing system is installed in the enclosed spaces containing the CNG storage. Special consideration should be given to the extinguishing of jet-fires.

## 6.7 Pressure relief system

### 6.7.1 General

.1 All fuel storage tanks shall be provided with a pressure relief system appropriate to the design of the fuel containment system and the fuel being carried. Fuel storage hold spaces, interbarrier spaces, and tank connection spaces, which may be subject to pressures beyond their design capabilities, shall also be provided with a suitable pressure relief system. Pressure control systems specified in 6.9 shall be independent of the pressure relief systems.

.2 Fuel storage tanks which may be subject to external pressures above their design pressure shall be fitted with vacuum protection systems.

### 6.7.2 Pressure relief systems for liquefied gas fuel tanks

.1 If fuel release into the vacuum space of a vacuum insulated tank cannot be excluded, the vacuum space shall be protected by a pressure relief device which shall be connected to a vent system if the tanks are located below deck. On open deck a direct release into the atmosphere may be accepted by the BKI for tanks not exceeding the size of a 40 ft container if the released gas cannot enter safe areas.

.2 Liquefied gas fuel tanks shall be fitted with a minimum of 2 pressure relief valves (PRVs) allowing for disconnection of one PRV in case of malfunction or leakage.

.3 Interbarrier spaces shall be provided with pressure relief devices<sup>9)</sup>. For membrane systems, the designer shall demonstrate adequate sizing of interbarrier space PRVs.

.4 The setting of the PRVs shall not be higher than the vapour pressure that has been used in the design of the tank. Valves comprising not more than 50% of the total relieving capacity may be set at a pressure up to 5% above MARVS to allow sequential lifting, minimizing unnecessary release of vapour.

.5 The following temperature regulations apply to PRVs fitted to pressure relief systems:

.5.1 PRVs on fuel tanks with a design temperature below 0°C shall be designed and arranged to prevent their becoming inoperative due to ice formation;

.5.2 the effects of ice formation due to ambient temperatures shall be considered in the construction and arrangement of PRVs;

.5.3 PRVs shall be constructed of materials with a melting point above 925°C. Lower melting point materials for internal parts and seals may be accepted provided that fail-safe operation of the PRV is not compromised; and

.5.4 sensing and exhaust lines on pilot operated relief valves shall be of suitably robust construction to prevent damage.

.6 In the event of a failure of a fuel tank PRV a safe means of emergency isolation shall be available.

.6.1 procedures shall be provided and included in the operation manual (refer to [Section 18](#));

.6.2 the procedures shall allow only one of the installed PRVs for the liquefied gas fuel tanks to be isolated, physical interlocks shall be included to this effect; and

.6.3 isolation of the PRV shall be carried out under the supervision of the master. This action shall be recorded in the ship's log, and at the PRV.

.7 Each pressure relief valve installed on a liquefied gas fuel tank shall be connected to a venting system, which shall be:

.7.1 so constructed that the discharge will be unimpeded and normally be directed vertically upwards at the exit;

.7.2 arranged to minimize the possibility of water or snow entering the vent system; and

.7.3 arranged such that the height of vent exits shall normally not be less than B/3 or 6 m, whichever is the greater, above the weather deck and 6 m above working areas and walkways. However, vent mast height could be limited to lower value according to special consideration by the BKI.

.8 The outlet from the pressure relief valves shall normally be located at least 10 m from the nearest:

.8.1 air intake, air outlet or opening to accommodation, service and control spaces, or other non-hazardous area; and

.8.2 exhaust outlet from machinery installations.

<sup>9)</sup> Refer to [Guidance for Code and Convention Interpretations \(Pt.1, Vol.Y\) Sec.4, GC9](#) entitled Guidance for sizing pressure relief systems for interbarrier spaces, 1988.

.9 All other fuel gas vent outlets shall also be arranged in accordance with 6.7.2.7 and 6.7.2.8. Means shall be provided to prevent liquid overflow from gas vent outlets, due to hydrostatic pressure from spaces to which they are connected.

.10 In the vent piping system, means for draining liquid from places where it may accumulate shall be provided. The PRVs and piping shall be arranged so that liquid can, under no circumstances, accumulate in or near the PRVs.

.11 Suitable protection screens of not more than 13 mm square mesh shall be fitted on vent outlets to prevent the ingress of foreign objects without adversely affecting the flow.

.12 All vent piping shall be designed and arranged not to be damaged by the temperature variations to which it may be exposed, forces due to flow or the ship's motions.

.13 PRVs shall be connected to the highest part of the fuel tank. PRVs shall be positioned on the fuel tank so that they will remain in the vapour phase at the filling limit (FL) as given in 6.8, under conditions of 15° list and 0,015L trim, where L is defined in 2.2.25.

### 6.7.3 Sizing of pressure relieving system

#### .1 Sizing of pressure relief valves

.1.1 PRVs shall have a combined relieving capacity for each liquefied gas fuel tank to discharge the greater of the following, with not more than a 20% rise in liquefied gas fuel tank pressure above the MARVS:

.1.1.1 the maximum capacity of the liquefied gas fuel tank inerting system if the maximum attainable working pressure of the liquefied gas fuel tank inerting system exceeds the MARVS of the liquefied gas fuel tanks; or

.1.1.2 vapours generated under fire exposure computed using the following formula<sup>10)</sup> :

$$Q = F G A^{0,82} \quad \text{m}^3/\text{s}$$

where:

Q = minimum required rate of discharge of air at standard conditions of 273,15 Kelvin (K) and 0,1013 MPa.

F = fire exposure factor for different liquefied gas fuel types:

= 1,0 for tanks without insulation located on deck;

= 0,5 for tanks above the deck when insulation is approved by the BKI. (Approval will be based on the use of a fireproofing material, the thermal conductance of insulation, and its stability under fire exposure);

= 0,5 for uninsulated independent tanks installed in holds;

= 0,2 for insulated independent tanks in holds (or uninsulated independent tanks in insulated holds);

= 0,1 for insulated independent tanks in inerted holds (or uninsulated independent tanks in inerted, insulated holds); and

= 0,1 for membrane tanks.

= 0,1 For independent tanks partly protruding through the weather decks, the fire exposure factor shall be determined on the basis of the surface areas above and below deck.

G = gas factor according to formula:

<sup>10)</sup> For interpretation refer to [Guidance for Code and Convention Interpretations \(Pt.1, Vol.Y\) Sec.5,GF 7.](#)



$$G = \frac{12,4}{LD} \sqrt{\frac{ZT}{M}}$$

where:

- T = temperature in Kelvin at relieving conditions, i.e. 120% of the pressure at which the pressure relief valve is set;
- L = latent heat of the material being vaporized at relieving conditions, in kJ/kg;
- D = a constant based on relation of specific heats k and is calculated as follows:

$$D = \sqrt{k \left( \frac{2}{k+1} \right)^{\frac{k+1}{k-1}}}$$

where:

- k = ratio of specific heats at relieving conditions, and the value of which is between 1,0 and 2,2. If k is not known, D = 0,606 shall be used;
- Z = compressibility factor of the gas at relieving conditions; if not known, Z = 1,0 shall be used;
- M = molecular mass of the product.

The gas factor of each liquefied gas fuel to be carried is to be determined and the highest value shall be used for PRV sizing.

- A = external surface area of the tank (m<sup>2</sup>), as for different tank types, as shown in [Figure 6.7.1](#).

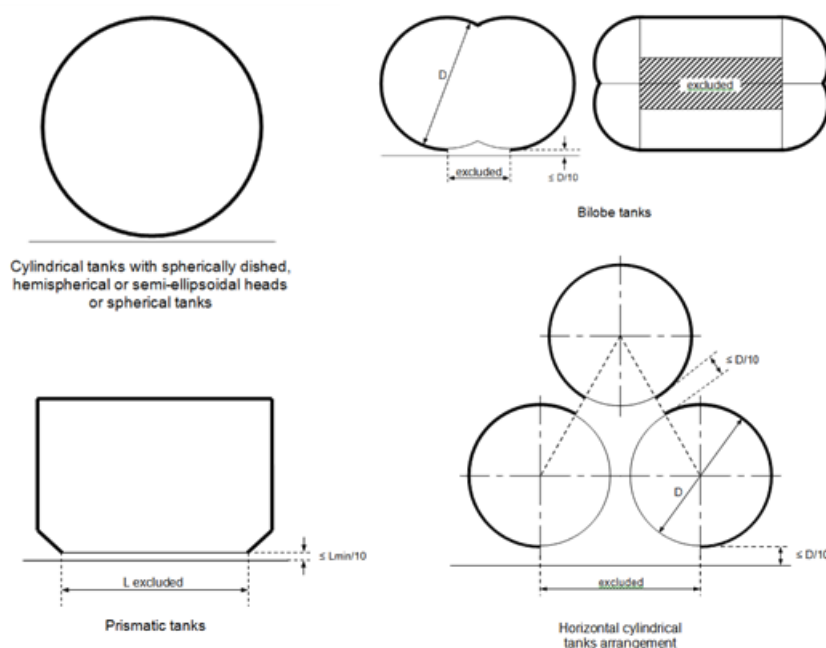

Figure 6.7.1: External surface area for different tank type <sup>10)</sup>

.1.2 For vacuum insulated tanks in fuel storage hold spaces and for tanks in fuel storage hold spaces separated from potential fire loads by coffer dams or surrounded by ship spaces with no fire load the



following applies: If the pressure relief valves have to be sized for fire loads the fire factors according may be reduced to the following values:

$$F = 0,5 \text{ to } F = 0,25$$

$$F = 0,2 \text{ to } F = 0,1$$

The minimum fire factor is  $F = 0,1$

**.1.3** The required mass flow of air at relieving conditions is given by:

$$M_{\text{air}} = Q * \rho_{\text{air}} \text{ [kg/s]}$$

where density of air ( $\rho_{\text{air}}$ ) = 1,293 kg/m<sup>3</sup> (air at 273,15 K, 0,1013 MPa).

## **.2 Sizing of vent pipe system**

**.2.1** Pressure losses upstream and downstream of the PRVs, shall be taken into account when determining their size to ensure the flow capacity required by [6.7.3.1](#).

### **.2.2 Upstream pressure losses**

**.2.2.1** the pressure drop in the vent line from the tank to the PRV inlet shall not exceed 3% of the valve set pressure at the calculated flow rate, in accordance with [6.7.3.1](#);

**.2.2.2** pilot-operated PRVs shall be unaffected by inlet pipe pressure losses when the pilot senses directly from the tank dome; and

**.2.2.3** pressure losses in remotely sensed pilot lines shall be considered for flowing type pilots.

### **.2.3 Downstream pressure losses**

**.2.3.1** Where common vent headers and vent masts are fitted, calculations shall include flow from all attached PRVs.

**.2.3.2** The built-up back pressure in the vent piping from the PRV outlet to the location of discharge to the atmosphere, and including any vent pipe interconnections that join other tanks, shall not exceed the following values:

**.2.3.2.1** for unbalanced PRVs: 10% of MARVS;

**.2.3.2.2** for balanced PRVs: 30% of MARVS; and

**.2.3.2.3** for pilot operated PRVs: 50% of MARVS.

Alternative values provided by the PRV manufacturer may be accepted.

**.2.4** To ensure stable PRV operation, the blow-down shall not be less than the sum of the inlet pressure loss and 0,02 MARVS at the rated capacity.

## **6.8 Loading limit for liquefied gas fuel tanks**

**6.8.1** Storage tanks for liquefied gas shall not be filled to more than a volume equivalent to 98% full at the reference temperature as defined in [2.2.36](#). A loading limit curve for actual fuel loading temperatures shall be prepared from the following formula:

$$LL = FL \frac{\rho_R}{\rho_L}$$

where:

LL = loading limit as defined in [2.2.27](#), expressed in per cent;

FL = filling limit as defined in [2.2.16](#) expressed in per cent, here 98%;

$\rho_R$  = relative density of fuel at the reference temperature; and

$\rho_L$  = relative density of fuel at the loading temperature.

**6.8.2** In cases where the tank insulation and tank location make the probability very small for the tank contents to be heated up due to an external fire, special considerations may be made to allow a higher loading limit than calculated using the reference temperature, but never above 95%. This also applies in cases where a second system for pressure maintenance is installed, (refer to 6.9). However, if the pressure can only be maintained / controlled by fuel consumers, the loading limit as calculated in 6.8.1 shall be used.<sup>11)</sup>

**6.8.3** For ships constructed on or after 1 January 2024, in cases where the tank insulation and tank location make the probability very small for the tank contents to be heated up due to an external fire, special considerations may be made to allow a higher loading limit than calculated using the reference temperature, but never above 95%.

## 6.9 Maintaining of fuel storage condition

### 6.9.1 Control of tank pressure and temperature

.1 With the exception of liquefied gas fuel tanks designed to withstand the full gauge vapour pressure of the fuel under conditions of the upper ambient design temperature, liquefied gas fuel tanks' pressure and temperature shall be maintained at all times within their design range<sup>12)</sup> by means acceptable to the BKI, e.g. by one of the following methods:

- .1.1 reliquefaction of vapours;
- .1.2 thermal oxidation of vapours;
- .1.3 pressure accumulation;
- .1.4 liquefied gas fuel cooling.

The method chosen shall be capable of maintaining tank pressure below the set pressure of the tank pressure relief valves for a period of 15 days assuming full tank at normal service pressure and the ship in idle condition, i.e. only power for domestic load is generated.

.2 Venting of fuel vapour for control of the tank pressure is not acceptable except in emergency situations.<sup>12)</sup>

### 6.9.2 Design of systems

.1 For worldwide service, the upper ambient design temperature shall be sea 32°C and air 45°C. For service in particularly hot or cold zones, these design temperatures shall be increased or decreased, to the satisfaction of the BKI.

.2 The overall capacity of the system shall be such that it can control the pressure within the design conditions without venting to atmosphere.

### 6.9.3 Reliquefaction systems

.1 The reliquefaction system shall be designed and calculated according to 6.9.3.2. The system has to be sized in a sufficient way also in case of no or low consumption.

.2 The reliquefaction system shall be arranged in one of the following ways:

- .2.1 a direct system where evaporated fuel is compressed, condensed and returned to the fuel tanks;
- .2.2 an indirect system where fuel or evaporated fuel is cooled or condensed by refrigerant without being compressed;
- .2.3 a combined system where evaporated fuel is compressed and condensed in a fuel/refrigerant heat exchanger and returned to the fuel tanks; and

<sup>11)</sup> For interpretation refer to [Guidance for Code and Convention Interpretations \(Pt.1, Vol.Y\) Sec.5,GF 16](#).

<sup>12)</sup> For interpretation refer to [Guidance for Code and Convention Interpretations \(Pt.1, Vol.Y\) Sec.5,GF 8](#).

.2.4 if the reliquefaction system produces a waste stream containing methane during pressure control operations within the design conditions, these waste gases shall, as far as reasonably practicable, be disposed of without venting to atmosphere.

#### **6.9.4 Thermal oxidation systems**

.1 Thermal oxidation can be done by either consumption of the vapours according to the regulations for consumers described in these guidelines or in a dedicated gas combustion unit (GCU). It shall be demonstrated that the capacity of the oxidation system is sufficient to consume the required quantity of vapours. In this regard periods of slow steaming and/or no consumption from propulsion or other services of the vessel shall be considered.

#### **6.9.5 Compatibility**

.1 Refrigerants or auxiliary agents used for refrigeration or cooling of fuel shall be compatible with the fuel they may come in contact with (not causing any hazardous reaction or excessively corrosive products). In addition, when several refrigerants or agents are used, these shall be compatible with each other.

#### **6.9.6 Availability of systems**

.1 The availability of the system and its supporting auxiliary services shall be such that in case of a single failure (of mechanical non-static component or a component of the control systems) the fuel tank pressure and temperature can be maintained by another service/system.

.2 Heat exchangers that are solely necessary for maintaining the pressure and temperature of the fuel tanks within their design ranges shall have a standby heat exchanger unless they have a capacity in excess of 25% of the largest required capacity for pressure control and they can be repaired on board without external sources.

### **6.10 Atmospheric control within the fuel containment system**

**6.10.1** A piping system shall be arranged to enable each fuel tank to be safely gas-freed, and to be safely filled with fuel from a gas-free condition. The system shall be arranged to minimize the possibility of pockets of gas or air remaining after changing the atmosphere.

**6.10.2** The system shall be designed to eliminate the possibility of a flammable mixture existing in the fuel tank during any part of the atmosphere change operation by utilizing an inerting medium as an intermediate step.

**6.10.3** Gas sampling points shall be provided for each fuel tank to monitor the progress of atmosphere change.

**6.10.4** Inert gas utilized for gas freeing of fuel tanks may be provided externally to the ship.

#### **6.11 Atmosphere control within fuel storage hold spaces (Fuel containment systems other than type C independent tanks)**

**6.11.1** Interbarrier and fuel storage hold spaces associated with liquefied gas fuel containment systems requiring full or partial secondary barriers shall be inerted with a suitable dry inert gas and kept inerted with make-up gas provided by a shipboard inert gas generation system, or by shipboard storage, which shall be sufficient for normal consumption for at least 30 days. Shorter periods may be considered by the BKI depending on the ship's service.

**6.11.2** Alternatively, the spaces referred to in 6.11.1 requiring only a partial secondary barrier may be filled with dry air provided that the ship maintains a stored charge of inert gas or is fitted with an inert gas generation system sufficient to inert the largest of these spaces, and provided that the configuration of the spaces and the relevant vapour detection systems, together with the capability of the inerting arrangements, ensures that any leakage from the liquefied gas fuel tanks will be rapidly detected and inerting effected before a dangerous condition can develop. Equipment for the provision of sufficient dry air of suitable quality to satisfy the expected demand shall be provided.

## **6.12 Environmental control of spaces surrounding type C independent tanks**

**6.12.1** Spaces surrounding liquefied gas fuel tanks shall be filled with suitable dry air and be maintained in this condition with dry air provided by suitable air drying equipment. This is only applicable for liquefied gas fuel tanks where condensation and icing due to cold surfaces is an issue.

## **6.13 Requirement on inerting**

**6.13.1** Arrangements to prevent back-flow of fuel vapour into the inert gas system shall be provided as specified below.

**6.13.2** To prevent the return of flammable gas to any non-hazardous spaces, the inert gas supply line shall be fitted with two shutoff valves in series with a venting valve in between (double block and bleed valves). In addition a closable non-return valve shall be installed between the double block and bleed arrangement and the fuel system. These valves shall be located outside non-hazardous spaces.

**6.13.3** Where the connections to the fuel piping systems are non-permanent, two non-return valves may be substituted for the valves required in 6.13.2.

**6.13.4** The arrangements shall be such that each space being inerted can be isolated and the necessary controls and relief valves, etc. shall be provided for controlling pressure in these spaces.

**6.13.5** Where insulation spaces are continually supplied with an inert gas as part of a leak detection system, means shall be provided to monitor the quantity of gas being supplied to individual spaces.

## **6.14 Inert gas production and storage on board**

**6.14.1** The equipment shall be capable of producing inert gas with oxygen content at no time greater than 5% by volume. A continuous-reading oxygen content meter shall be fitted to the inert gas supply from the equipment and shall be fitted with an alarm set at a maximum of 5% oxygen content by volume.

**6.14.2** An inert gas system shall have pressure controls and monitoring arrangements appropriate to the fuel containment system.

**6.14.3** Where a nitrogen generator or nitrogen storage facilities are installed in a separate compartment outside of the engine-room, the separate compartment shall be fitted with an independent mechanical extraction ventilation system, providing a minimum of 6 air changes per hour. A low oxygen alarm shall be fitted.

**6.14.4** Nitrogen pipes shall only be led through well ventilated spaces. Nitrogen pipes in enclosed spaces shall:

- be fully welded;
- have only a minimum of flange connections as needed for fitting of valves; and
- be as short as possible.

## Section 7 Material and General Pipe Design

7.1	Goal . . . . .	7-1
7.2	Functional requirements . . . . .	7-1
7.3	General pipe design . . . . .	7-1
7.4	Requirements for materials . . . . .	7-4

### 7.1 Goal

**7.1.1** The goal of this Section is to ensure the safe handling of fuel, under all operating conditions, to minimize the risk to the ship, personnel and to the environment, having regard to the nature of the products involved.

**C7.1.1** Fuel in the context of this Section means natural gas, either in its liquefied or gaseous state.

### 7.2 Functional requirements

**7.2.1** This section relates to functional requirements in 3.2.1, 3.2.5, 3.2.6, 3.2.8, 3.2.9 and 3.2.10. In particular, the following apply:

- .1 Fuel piping shall be capable of absorbing thermal expansion or contraction caused by extreme temperatures of the fuel without developing substantial stresses.
- .2 Provision shall be made to protect the piping, piping system and components and fuel tanks from excessive stresses due to thermal movement and from movements of the fuel tank and hull structure.
- .3 If the fuel gas contains heavier constituents that may condense in the system, means for safely removing the liquid shall be fitted.
- .4 Low temperature piping shall be thermally isolated from the adjacent hull structure, where necessary, to prevent the temperature of the hull from falling below the design temperature of the hull material.

### 7.3 General pipe design

#### 7.3.1 General

- .1 Fuel pipes and all the other piping needed for a safe and reliable operation and maintenance shall be colour marked in accordance with a standard at least equivalent to those acceptable to the Organization<sup>1)</sup>.
- .2 Where tanks or piping are separated from the ship's structure by thermal isolation, provision shall be made for electrically bonding to the ship's structure both the piping and the tanks. All gasketed pipe joints and hose connections shall be electrically bonded.
- .3 All pipelines or components which may be isolated in a liquid full condition shall be provided with relief valves.
- .4 Pipework, which may contain low temperature fuel, shall be thermally insulated to an extent which will minimize condensation of moisture.
- .5 Piping other than fuel supply piping and cabling may be arranged in the double wall piping or duct provided that they do not create a source of ignition or compromise the integrity of the double pipe or duct. The double wall piping or duct shall only contain piping or cabling necessary for operational purposes.

---

<sup>1)</sup> Refer to EN ISO 14726:2008 Ships and marine technology – Identification colours for the content of piping systems.

### 7.3.2 Wall thickness

.1 The minimum wall thickness shall be calculated as follows:

$$t = \frac{(t_0 + b + c)}{(1 - a/100)} \quad [\text{mm}]$$

where:

$t_0$  = theoretical thickness

$$t_0 = \frac{P D}{(2,0 K_e + P)} \quad [\text{mm}]$$

with:

P = design pressure [MPa] referred to in 7.3.3;

D = outside diameter [mm];

K = allowable stress [ $\text{N}/\text{mm}^2$ ] referred to in 7.3.4; and

e = efficiency factor equal to 1,0 for seamless pipes and for longitudinally or spirally welded pipes, delivered by approved manufacturers of welded pipes, that are considered equivalent to seamless pipes when non-destructive testing on welds is carried out in accordance with recognized standards. In other cases an efficiency factor of less than 1,0, in accordance with recognized standards, may be required depending on the manufacturing process;

b = allowance for bending [mm]. The value of b shall be chosen so that the calculated stress in the bend, due to internal pressure only, does not exceed the allowable stress. Where such justification is not given, b shall be:

$$b = D \cdot t_0 / 2,5 r \quad [\text{mm}]$$

with

r = mean radius of the bend [mm];

c = corrosion allowance [mm]. If corrosion or erosion is expected the wall thickness of the piping shall be increased over that required by other design regulations. This allowance shall be consistent with the expected life of the piping; and

a = negative manufacturing tolerance for thickness [%]

### 7.3.3 Design condition

.1 The greater of the following design conditions shall be used for piping, piping system and components as appropriate <sup>2)3)</sup>:

.1.1 for systems or components which may be separated from their relief valves and which contain only vapour at all times, vapour pressure at 45°C assuming an initial condition of saturated vapour in the system at the system operating pressure and temperature; or

.1.2 the MARVS of the fuel tanks and fuel processing systems; or

.1.3 the pressure setting of the associated pump or compressor discharge relief valve; or

<sup>2)</sup> Lower values of ambient temperature regarding design condition in 7.3.3.1.1 may be accepted by the BKI for ships operating in restricted areas. Conversely, higher values of ambient temperature may be required.

<sup>3)</sup> For ships on voyages of restricted duration,  $P_0$  may be calculated based on the actual pressure rise during the voyage and account may be taken of any thermal insulation of the tank. Reference is made to the *Application of amendments to gas carrier codes concerning type C tank loading limits (SIGTTO/IACS)*.

- .1.4 the maximum total discharge or loading head of the fuel piping system; or
- .1.5 the relief valve setting on a pipeline system.
- .2 Piping, piping systems and components shall have a minimum design pressure of 1,0 MPa except for open ended lines where it is not to be less than 0,5 MPa.

#### 7.3.4 Allowable stress

- .1 For pipes made of steel including stainless steel, the allowable stress to be considered in the formula of the strength thickness in 7.3.2.1 shall be the lower of the following values:

$$R_m/2,7 \text{ or } R_e/1,8$$

where:

- $R_m$  = specified minimum tensile strength at room temperature [N/mm<sup>2</sup>]; and
- $R_e$  = specified minimum yield stress at room temperature [N/mm<sup>2</sup>]. If the stress strain curve does not show a defined yield stress, the 0,2% proof stress applies.

- .2 Where necessary for mechanical strength to prevent damage, collapse, excessive sag or buckling of pipes due to superimposed loads, the wall thickness shall be increased over that required by 7.3.2 or, if this is impracticable or would cause excessive local stresses, these loads shall be reduced, protected against or eliminated by other design methods. Such superimposed loads may be due to; supports, ship deflections, liquid pressure surge during transfer operations, the weight of suspended valves, reaction to loading arm connections, or otherwise.
- .3 For pipes made of materials other than steel, the allowable stress shall be considered by the BKI.
- .4 High pressure fuel piping systems shall have sufficient constructive strength. This shall be confirmed by carrying out stress analysis and taking into account:
  - .4.1 stresses due to the weight of the piping system;
  - .4.2 acceleration loads when significant; and
  - .4.3 internal pressure and loads induced by hog and sag of the ship.
- .5 When the design temperature is minus 110°C or colder, a complete stress analysis, taking into account all the stresses due to weight of pipes, including acceleration loads if significant, internal pressure, thermal contraction and loads induced by hog and sag of the ship shall be carried out for each branch of the piping system.

#### 7.3.5 Flexibility of piping

- .1 The arrangement and installation of fuel piping shall provide the necessary flexibility to maintain the integrity of the piping system in the actual service situations, taking potential for fatigue into account.

#### 7.3.6 Piping fabrication and joining details

- .1 Flanges, valves and other fittings shall comply with a standard acceptable to the BKI, taking into account the design pressure defined in 7.3.3.1. For bellows and expansion joints used in vapour service, a lower minimum design pressure than defined in 7.3.3.1 may be accepted.
- .2 All valves and expansion joints used in high pressure fuel piping systems shall be approved according to a standard acceptable to the BKI.
- .3 The piping system shall be joined by welding with a minimum of flange connections. Gaskets shall be protected against blow-out.

.4 Piping fabrication and joining details shall comply with the following:

#### .4.1 Direct connections

.4.1.1 Butt-welded joints with complete penetration at the root may be used in all applications. For design temperatures colder than minus 10°C, butt welds shall be either double welded or equivalent to a double welded butt joint. This may be accomplished by use of a backing ring, consumable insert or inert gas back-up on the first pass. For design pressures in excess of 1,0 MPa and design temperatures of minus 10°C or colder, backing rings shall be removed.

.4.1.2 Slip-on welded joints with sleeves and related welding, having dimensions in accordance with recognized standards, shall only be used for instrument lines and open-ended lines with an external diameter of 50 mm or less and design temperatures not colder than minus 55°C.

.4.1.3 Screwed couplings complying with recognized standards shall only be used for accessory lines and instrumentation lines with external diameters of 25 mm or less.

#### .4.2 Flanged connections

.4.2.1 Flanges in flange connections shall be of the welded neck, slip-on or socket welded type; and

.4.2.2 For all piping except open ended, the following restrictions apply:

.4.2.2.1 For design temperatures colder than minus 55°C, only welded neck flanges shall be used; and

.4.2.2.2 For design temperatures colder than minus 10°C, slip-on flanges shall not be used in nominal sizes above 100 mm and socket welded flanges shall not be used in nominal sizes above 50 mm.

#### .4.3 Expansion joints

Where bellows and expansion joints are provided in accordance with 7.3.6.1 the following apply:

.4.3.1 if necessary, bellows shall be protected against icing;

.4.3.2 slip joints shall not be used except within the liquefied gas fuel storage tanks; and

.4.3.3 bellows shall normally not be arranged in enclosed spaces.

#### .4.4 Other connections

Piping connections shall be joined in accordance with 7.3.6.4.1 to 7.3.6.4.3 but for other exceptional cases the BKI may consider alternative arrangements.

## 7.4 Requirements for materials

### 7.4.1 Metallic materials

.1 Materials for fuel containment and piping systems shall comply with the minimum regulations given in the following tables:

— Table 7.1: Plates, pipes (seamless and welded), sections and forgings for fuel tanks and process pressure vessels for design temperatures not lower than 0°C.

C- Additionally, Table 7.1a is to also be complied for plates, pipes (seamless and welded), sections and forgings for cargo tanks, fuel tanks and process pressure vessels for design temperatures not lower than 0°C

— Table 7.2: Plates, sections and forgings for fuel tanks, secondary barriers and process pressure vessels for design temperatures below 0°C and down to minus 55°C.

C- Additionally, the following tables are to also be complied:

C- Table 7.2a: Plates, sections and forgings for cargo tanks, fuel tanks, secondary barriers and process pressure vessels for design temperatures below 0°C and strictly down to minus 10°C

C- Table 7.2b: Plates, sections and forgings for cargo tanks, fuel tanks, secondary barriers and process pressure vessels for design temperatures below minus 10°C and down to minus 55°C



- [Table 7.3](#): Plates, sections and forgings for fuel tanks, secondary barriers and process pressure vessels for design temperatures below minus 55°C and down to minus 165°C.
- C- Additionally, [Table 7.3a](#) is to also be complied for plates, sections and forgings for cargo tanks, fuel tanks, secondary barriers and process pressure vessels for design temperatures below minus 55°C and down to minus 165°C
- [Table 7.4](#): Pipes (seamless and welded), forgings and castings for fuel and process piping for design temperatures below 0°C and down to minus 165°C.
- [Table 7.5](#): Plates and sections for hull structures required by [6.4.13.1.1.2](#).

**Table 7.1: Plates, Pipes (Seamless and Welded) <sup>1) 2)</sup> Sections and Forgings for Fuel Tanks and Process Pressure Vessels for Design Temperatures Not Lower Than 0°C**

CHEMICAL COMPOSITION AND HEAT TREATMENT		
<input type="checkbox"/> Carbon-manganese steel		
<input type="checkbox"/> Fully killed fine grain steell		
<input type="checkbox"/> Small additions of alloying elements by agreement with the BKI		
<input type="checkbox"/> Composition limits to be approved by the BKI		
<input type="checkbox"/> Normalized, or quenched and tempered <sup>4)</sup>		
TENSILE AND TOUGHNESS (IMPACT) TEST REGULATIONS		
Sampling frequency		
<input type="checkbox"/> Plates	Each "piece" to be tested	
<input type="checkbox"/> Sections and forgings	Each "batch" to be tested	
Mechanical properties		
<input type="checkbox"/> Tensile properties	Specified minimum yield stress not to exceed 410 N/mm <sup>2</sup> <sup>5)</sup>	
Toughness (Charpy V-notch test)		
<input type="checkbox"/> Plates	Longitudinal test pieces. Minimum average energy (KV) 41J	
<input type="checkbox"/> Sections and forgings	Longitudinal test pieces. Minimum average energy (KV) 41J	
<input type="checkbox"/> Test temperature	Thickness t (mm)	Test temperature (°C)
	t ≤ 20	0
	20 < t ≤ 40 <sup>3)</sup>	-20
Notes		
1) For seamless pipes and fittings normal practice applies. The use of longitudinally and spirally welded pipes shall be specially approved by the BKI.		
2) Charpy V-notch impact tests are not required for pipes.		
3) This Table is generally applicable for material thicknesses up to 40 mm. Thicknesses between 40-50 mm shall be conducted as <a href="#">Table 7.1a</a> . Proposals for greater thicknesses shall be approved by the BKI.		
4) A controlled rolling procedure or TMCP may be used as an alternative.		
5) Materials with specified minimum yield stress exceeding 410 N/mm <sup>2</sup> may be approved by the BKI. For these materials, particular attention shall be given to the hardness of the welded and heat affected zones.		

**Table 7.1a: Plates, Pipes (Seamless and Welded), Sections and Forgings for Cargo Tanks Fuel Tanks And Process Pressure Vessels for Design Temperatures Not Lower Than 0°C**

CHARPY V-NOTCH IMPACT TEST REQUIREMENTS		
Test temperature	Thickness t (mm)	Test temperature (°C)
	40 < t ≤ 50 <sup>1)</sup>	-20 <sup>2)</sup>
	40 < t ≤ 50 <sup>1)</sup>	-30 <sup>3)</sup>

**Notes**

1) A further set of impact test at mid thickness for products with t>40mm is required except rolled steels specified in [Rules for Material \(Pt.1, Vol.V\) Section 4](#).

2) Applies to type C independent tanks and process pressure vessels. In addition, post-weld stress relief heat treatment shall be performed. Exemption to post-weld stress relief heat treatment based on alternative approach (e.g. Engineering Critical Assessment) shall be approved by The BKI or shall be to recognized standards.

3) Applies to cargo tank or fuel tank other than type C.

**Table 7.2: Plates, Sections and Forgings <sup>1)</sup> for Fuel Tanks, Secondary Barriers and Process Pressure Vessels for Design Temperatures Below 0°C and Down to Minus 55°C; Maximum thickness 25 mm <sup>2)</sup>**

CHEMICAL COMPOSITION AND HEAT TREATMENT					
<input type="checkbox"/> Carbon-manganese steel					
<input type="checkbox"/> Fully killed, aluminium treated fine grain steel					
<input type="checkbox"/> Chemical composition (ladle analysis)					
C	Mn	Si	S	P	
0,16% max. <sup>3)</sup>	0,70-1.60%	0,10-0,50%	0,025% max.	0,025% max.	
Optional additions: Alloys and grain refining elements may be generally in accordance with the following					
Ni	Cr	Mo	Cu	Nb	
0,80% max.	0,25% max.	0,08% max.	0,35% max.	0,05% max.	
V					
0,10% max.					
Al content total 0,020% min. (Acid soluble 0,015% min.)					
<input type="checkbox"/> Normalized, or quenched and tempered <sup>4)</sup>					
TENSILE AND TOUGHNESS (IMPACT) TEST REGULATIONS					
Sampling frequency					
<input type="checkbox"/> Plates	Each 'piece' to be tested				
<input type="checkbox"/> Sections and forgings	Each 'batch' to be tested				
Mechanical properties					
<input type="checkbox"/> Tensile properties	Specified minimum yield stress not to exceed 410 N/mm <sup>2</sup> <sup>5)</sup>				
Toughness (Charpy V-notch test)					
<input type="checkbox"/> Plates	Transverse test pieces. Minimum average energy value (KV) 27J				
<input type="checkbox"/> Sections and forgings	Longitudinal test pieces. Minimum average energy (KV) 41J				
<input type="checkbox"/> Test temperature	5°C below the design temperature or -20°C whichever is lower				

**Notes**

1) The Charpy V-notch and chemistry regulations for forgings may be specially considered by the BKI.

2) For material thickness of more than 25 mm, Charpy V-notch tests shall be conducted as follows:

**Table 7.2: Plates, Sections and Forgings <sup>1)</sup> for Fuel Tanks, Secondary Barriers and Process Pressure Vessels for Design Temperatures Below 0°C and Down to Minus 55°C; Maximum thickness 25 mm <sup>2)</sup>**  
 (continued)

Material thickness (mm)	Test temperature (°C)
25 < t ≤ 30	10°C below design temperature or -20°C whichever is lower
30 < t ≤ 35	15°C below design temperature or -20°C whichever is lower
35 < t ≤ 40	20°C below design temperature
40 < t	See <a href="#">Table 7.2a</a> and <a href="#">Table 7.2b</a> . Temperature approved by the BKI

The impact energy value shall be in accordance with the table for the applicable type of test specimen. Materials for tanks and parts of tanks which are completely thermally stress relieved after welding may be tested at a temperature 5°C below design temperature or -20°C whichever is lower.

For thermally stress relieved reinforcements and other fittings, the test temperature shall be the same as that required for the adjacent tank-shell thickness.

3) By special agreement with the BKI, the carbon content may be increased to 0,18% maximum provided the design temperature is not lower than -40°C

4) A controlled rolling procedure or thermos-mechanical controlled processing (TMCP) may be used as an alternative.

5) Materials with specified minimum yield stress exceeding 410 N/mm<sup>2</sup> may be approved by the BKI. For these materials, particular attention shall be given to the hardness of the welded and heat affected zones.

Guidance:  
 For materials exceeding 25 mm in thickness for which the test temperature is -60°C or lower, the application of specially treated steels or steels in accordance with [Table 7.3](#) may be necessary.

**Table 7.2a: Plates, Sections and Forgings for Cargo Tanks, Fuel Tanks, Secondary Barriers and Process Pressure Vessels for Design Temperatures Below 0°C and Strictly Down to Minus 10°C**

CHARPY V-NOTCH IMPACT TEST REQUIREMENTS		
Test temperature	Thickness t (mm)	Test temperature (°C)
	40 < t ≤ 50 <sup>1)</sup>	5°C below design temperature or -20°C, whichever is lower <sup>2)</sup>
	40 < t ≤ 45 <sup>1)</sup>	25 °C below design temperature <sup>3)</sup>
	45 < t ≤ 50 <sup>1)</sup>	30 °C below design temperature <sup>3)</sup>

**Notes**

1) A further set of impact test at mid thickness for products with t>40mm is required except rolled steels specified in [Rules for Material \(Pt.1, Vol.V\) Sec. 4.](#)

2) Applies to type C independent tanks and process pressure vessels. In addition, post-weld stress relief heat treatment shall be performed. Exemption to post-weld stress relief heat treatment based on alternative approach (e.g. Engineering Critical Assessment) shall be approved by The BKI or shall be to recognized standards.

3) Applies to cargo tank or fuel tank other than type C.

**Table 7.2b: Plates, Sections and Forgings for Cargo Tanks, Fuel Tanks, Secondary Barriers and Process Pressure Vessels for Design Temperatures Below Minus 10°C and Down to Minus 55°C**

CHARPY V-NOTCH IMPACT TEST REQUIREMENTS		
Test temperature	Thickness t (mm)	Test temperature (°C)
	40 < t ≤ 50 <sup>1)</sup>	5°C below design temperature or -20°C, whichever is lower <sup>2)</sup>
	40 < t ≤ 45 <sup>1)</sup>	25 °C below design temperature <sup>3)</sup>
	45 < t ≤ 50 <sup>1)</sup>	30 °C below design temperature <sup>3)</sup>
<b>Notes</b>		
1) A further set of impact test at mid thickness for products with t>40mm is required except rolled steels specified in <a href="#">Rules for Material (Pt.1, Vol.V) Sec. 4.</a>		
2) <a href="#">Rules for Ships Carrying Liquefied Gases in Bulk (Pt.1, Vol.IX) Sec. 6.6.2.2</a> applies with regards to post-weld stress relief heat treatment. Exemption to post-weld stress relief heat treatment based on alternative approach (e.g. Engineering Critical Assessment) shall be approved by the BKI or shall be to recognized standards.		
3) Applies to cargo tank or fuel tank other than type C.		

**Table 7.3: Plates, Sections and Forgings <sup>1)</sup> for Fuel Tanks, Secondary Barriers and Process Pressure Vessels for Design Temperatures Below Minus 55°C and Down to Minus 165°C<sup>2)</sup>; Maximum thickness 25 mm <sup>3)4)</sup>**

Minimum design temp. (°C)	Chemical composition <sup>5)</sup> and heat treatment	Impact test temp. (°C)
-60	1,5% nickel steel - normalized or normalized and tempered or quenched and tempered or TMCP <sup>6)</sup>	-65
-65	2,25% nickel steel - normalized or normalized and tempered or quenched and tempered or TMCP <sup>6)7)</sup>	-70
-90	3,5% nickel steel - normalized or normalized and tempered or quenched and tempered or TMCP <sup>6)7)</sup>	-95
-105	5% nickel steel - normalized or normalized and tempered or quenched and tempered <sup>6)7)8)</sup>	-110
-165	9% nickel steel - double normalized and tempered or quenched and tempered <sup>6)</sup>	-196
-165	Austenitic steels, such as types 304, 304L, 316, 316L, 321 and 347 solution treated <sup>9)</sup>	-196
-165	High Manganese austenitic steel - hot rolling and controlled cooling <sup>10)11)12)</sup>	-196
-165	Aluminium alloys; such as type 5083 annealed	Not required
-165	Austenitic Fe-Ni alloy (36% nickel) Heat treatment as agreed	Not required
<b>TENSILE AND TOUGHNESS (IMPACT) TEST REGULATIONS</b>		
Sampling frequency		
<input type="checkbox"/> Plates	Each 'piece' to be tested	
<input type="checkbox"/> Sections and forgings	Each 'batch' to be tested	
Toughness (Charpy V-notch test)		
<input type="checkbox"/> Plates	Transverse test pieces. Minimum average energy value (KV) 27J	
<input type="checkbox"/> Sections and forgings	Longitudinal test pieces. Minimum average energy (KV) 41J	

**Table 7.3: Plates, Sections and Forgings <sup>1)</sup> for Fuel Tanks, Secondary Barriers and Process Pressure Vessels for Design Temperatures Below Minus 55°C and Down to Minus 165°C<sup>2)</sup>; Maximum thickness 25 mm <sup>3)4)</sup> (continued)**

Notes	
1) The impact test required for forgings used in critical applications shall be subject to special consideration by the BKI.	
2) The regulations for design temperatures below -165°C shall be specially agreed with the BKI.	
3) For materials 1,5% Ni, 2.25% Ni, 3.5% Ni and 5% Ni, with thicknesses greater than 25 mm, the impact tests shall be conducted as follows:	
Material thickness (mm)	Test temperature (°C)
25 < t ≤ 30	10°C below design temperature or -20°C whichever is lower
30 < t ≤ 35	15°C below design temperature or -20°C whichever is lower
35 < t ≤ 40	20°C below design temperature
The energy value shall be in accordance with the table for the applicable type of test specimen. For material thickness of more than 40 mm, the Charpy V-notch values shall be specially considered according to <a href="#">Table 7.3a</a> .	
4) For 9% Ni steels, austenitic stainless steels and aluminium alloys, thickness greater than 25 mm may be used.	
5) The chemical composition limits shall be in accordance with recognized standards.	
6) TMCP nickel steels will be subject to acceptance by the BKI.	
7) A lower minimum design temperature for quenched and tempered steels may be specially agreed with the BKI.	
8) A specially heat treated 5% nickel steel, for example triple heat treated 5% nickel steel, may be used down to -165°C, provided that the impact tests are carried out at -196°C.	
9) The impact test may be omitted subject to agreement with the BKI	
10) The use of the material shall be subject to the required conditions specified by the BKI based on the Guidelines developed by Organization. <sup>4)</sup>	
11) The impact test may not be omitted for high manganese austenitic steel.	
12) This requirements are applicable after 1 January 2026	

**Table 7.3a: Plates, Sections and Forgings for Cargo Tanks, Fuel Tanks, Secondary Barriers and Process Pressure Vessels for Design Temperatures Below Minus 55°C and Down to Minus 165°C**

CHARPY V-NOTCH IMPACT TEST REQUIREMENTS	
40 < t ≤ 45 <sup>1)</sup>	25 °C below design temperature
45 < t ≤ 50 <sup>1)</sup>	30 °C below design temperature
Notes	
1) A further set of impact test at mid thickness for products with t>40mm is required except rolled steels specified in <a href="#">Rules for Material (Pt.1, Vol.V) Sec. 4</a> .	

<sup>4)</sup> Refer to the Revised guidelines on the application of high manganese austenitic steel for cryogenic service (MSC.1/Circ.1599/Rev.2)

**Table 7.4: Pipes (Seamless and Welded)<sup>1)</sup>, Forgings<sup>2)</sup> and Castings<sup>2)</sup> for Fuel and Process Piping for Design Temperatures Below 0°C and Down to Minus 165°C<sup>3)</sup>. Maximum thickness 25 mm**

Minimum design temp. (°C)	Chemical composition <sup>5)</sup> and heat treatment	Impact test	
		Test temp. (°C)	Minimum average energy (KV)
-55	Carbon-manganese steel. Fully killed fine grain. Normalized or as agreed. <sup>6)</sup>	See note 4	27
-65	2,25% nickel steel. Normalized, Normalized and tempered or quenched and tempered. <sup>6)</sup>	-70	34
-90	3,5% nickel steel. Normalized, Normalized and tempered or quenched and tempered. <sup>6)</sup>	-95	34
-165	9% nickel steel <sup>7)</sup> . Double normalized and tempered or quenched and tempered.	-196	41
	Austenitic steels, such as types 304, 304L, 316, 316L, 321 and 347. Solution treated. <sup>8)</sup>	-196	41
	Aluminium alloys; such as type 5083 annealed		Not required
<b>TENSILE AND TOUGHNESS (IMPACT) TEST REGULATIONS</b>			
Sampling frequency			
<input type="checkbox"/> Each "batch" to be tested			
Toughness (Charpy V-notch test)			
<input type="checkbox"/> Impact test: Longitudinal test pieces			
Notes			
1) The use of longitudinally or spirally welded pipes shall be specially approved by the BKI.			
2) The regulations for forgings and castings may be subject to special consideration by the BKI.			
3) The regulations for design temperatures below -165°C shall be specially agreed with the BKI.			
4) The test temperature shall be 5°C below the design temperature or -20°C whichever is lower.			
5) The composition limits shall be in accordance with Recognized Standards.			
6) A lower design temperature may be specially agreed with the BKI for quenched and tempered materials.			
7) This chemical composition is not suitable for castings.			
8) Impact tests may be omitted subject to agreement with the BKI.			

**Table 7.5: Plates and Sections For Hull Structures Required by 6.4.13.1.1.2**

Minimum design temperature of hull structure (°C)	Maximum thickness (mm) for steel grades							
	A	B	D	E	AH	DH	EH	FH
0 and above	Recognized Standards							
down to -5	15	25	30	50	25	45	50	50
down to -10	X	20	25	50	20	40	50	50
down to -20	X	X	20	50	X	30	50	50
down to -30	X	X	X	40	X	20	40	50
Below -30	In accordance with Table 7.2 except that the thickness limitation given in Table 7.2 and in footnote 2 of that table does not apply.							
Notes								
'X' means steel grade not to be used.								

.2 Materials having a melting point below 925°C shall not be used for piping outside the fuel tanks.

- .3 For CNG tanks, the use of materials not covered above may be specially considered by the BKI.
- .4 Where required the outer pipe or duct containing high pressure gas in the inner pipe shall as a minimum fulfil the material regulations for pipe materials with design temperature down to minus 55°C in [Table 7.4](#).
- .5 The outer pipe or duct around liquefied gas fuel pipes shall as a minimum fulfil the material regulations for pipe materials with design temperature down to minus 165°C in [Table 7.4](#).

*This page intentionally left blank*



## Section 8 Bunkering

8.1	Goal . . . . .	8-1
8.2	Functional requirements . . . . .	8-1
8.3	Bunkering station . . . . .	8-1
8.4	Requirements for manifold . . . . .	8-2
8.5	Bunkering system . . . . .	8-2

### 8.1 Goal

**8.1.1** The goal of this section is to provide for suitable systems on board the ship to ensure that bunkering can be conducted without causing danger to persons, the environment or the ship.

**C8.1.1** Fuel in the context of this Section means natural gas, either in its liquefied or gaseous state.

### 8.2 Functional requirements

**8.2.1** This Section relates to functional requirements in 3.2.1 to 3.2.11 and 3.2.13 to 3.2.17. In particular, the following apply:

.1 The piping system for transfer of fuel to the storage tank shall be designed such that any leakage from the piping system cannot cause danger to personnel, the environment or the ship.

### 8.3 Bunkering station

#### 8.3.1 General

.1 The bunkering station shall be located on open deck so that sufficient natural ventilation is provided. Closed or semi-enclosed bunkering stations shall be subject to special consideration within the risk assessment.<sup>1)</sup>

.2 Connections and piping shall be so positioned and arranged that any damage to the fuel piping does not cause damage to the ship's fuel containment system resulting in an uncontrolled gas discharge.

.3 Arrangements shall be made for safe management of any spilled fuel.

.4 Suitable means shall be provided to relieve the pressure and remove liquid contents from pump suctions and bunker lines. Liquid is to be discharged to the liquefied gas fuel tanks or other suitable location.

.5 The surrounding hull or deck structures shall not be exposed to unacceptable cooling, in case of leakage of fuel.

.6 For CNG bunkering stations, low temperature steel shielding shall be considered to determine if the escape of cold jets impinging on surrounding hull structure is possible.

#### 8.3.2 Ships' fuel hoses

.1 Liquid and vapour hoses used for fuel transfer shall be compatible with the fuel and suitable for the fuel temperature.

.2 Hoses subject to tank pressure, or the discharge pressure of pumps or vapour compressors, shall be designed for a bursting pressure not less than five times the maximum pressure the hose can be subjected to during bunkering.

---

<sup>1)</sup> For interpretation refer to [Guidance for Code and Convention Interpretations \(Pt.1, Vol.Y\) Sec.5,GF 9](#).

## 8.4 Requirements for manifold

**8.4.1** The bunkering manifold shall be designed to withstand the external loads during bunkering. The connections at the bunkering station shall be of dry-disconnect type equipped with additional safety dry break-away coupling/ self-sealing quick release. The couplings shall be of a standard type.

## 8.5 Bunkering system

**8.5.1** An arrangement for purging fuel bunkering lines with inert gas shall be provided.

**8.5.2** The bunkering system shall be so arranged that no gas is discharged to the atmosphere during filling of storage tanks.

**8.5.3** A manually operated stop valve and a remote operated shutdown valve in series, or a combined manually operated and remote valve shall be fitted in every bunkering line close to the connecting point. It shall be possible to operate the remote valve in the control location for bunkering operations and/or from another safe location.

**8.5.4** Means shall be provided for draining any fuel from the bunkering pipes upon completion of operation.

**8.5.5** Bunkering lines shall be arranged for inerting and gas freeing. When not engaged in bunkering, the bunkering pipes shall be free of gas, unless the consequences of not gas freeing is evaluated and approved.

**8.5.6** In case bunkering lines are arranged with a cross-over it shall be ensured by suitable isolation arrangements that no fuel is transferred inadvertently to the ship side not in use for bunkering.

**8.5.7** A ship-shore link (SSL) or an equivalent means for automatic and manual ESD communication to the bunkering source shall be fitted.

**8.5.8** If not demonstrated to be required at a higher value due to pressure surge considerations a default time as calculated in accordance with [16.7.3.7](#) from the trigger of the alarm to full closure of the remote operated valve required by [8.5.3](#) shall be adjusted.

## Section 9 Fuel Supply to Consumers

9.1	Goal . . . . .	9-1
9.2	Functional requirements . . . . .	9-1
9.3	Redundancy of fuel supply . . . . .	9-1
9.4	Safety functions of gas supply system . . . . .	9-2
9.5	Fuel distribution outside of machinery space . . . . .	9-2
9.6	Fuel supply to consumers in gas-safe machinery spaces . . . . .	9-3
9.7	Gas fuel supply to consumers in ESD-protected machinery spaces . . . . .	9-3
9.8	Design of ventilated duct, outer pipe against inner pipe gas leakage . . . . .	9-4
9.9	Gas compressors and pumps . . . . .	9-4

### 9.1 Goal

The goal of this Section is to ensure safe and reliable distribution of fuel to the consumers.

**C9.1.1** Fuel in the context of this Section means natural gas, either in its liquefied or gaseous state.

### 9.2 Functional requirements

This Section is relates to functional requirements in 3.2.1 to 3.2.6,3.2.8 to 3.2.11 and 3.2.13 to 3.2.17. In particular, the following apply:

**9.2.1** the fuel supply system shall be so arranged that the consequences of any release of fuel will be minimized, while providing safe access for operation and inspection;

**9.2.2** the piping system for fuel transfer to the consumers shall be designed in a way that a failure of one barrier cannot lead to a leak from the piping system into the surrounding area causing danger to the persons on board, the environment or the ship <sup>1)</sup>; and

**9.2.3** fuel lines outside the machinery spaces shall be installed and protected so as to minimize the risk of injury to personnel and damage to the ship in case of leakage.

### 9.3 Redundancy of fuel supply

**9.3.1** For single fuel installations the fuel supply system shall be arranged with full redundancy and segregation all the way from the fuel tanks to the consumer, so that a leakage in one system does not lead to an unacceptable loss of power.

**9.3.2** For single fuel installations, the fuel storage shall be divided between two or more tanks. The tanks shall be located in separate compartments.

**9.3.3** For type C tank only, one tank may be accepted if two completely separate tank connection spaces are installed for the one tank.

---

<sup>1)</sup> For interpretation refer to [Guidance for Code and Convention Interpretations \(Pt.1, Vol.Y\) Sec.5,GF 19.](#)

## 9.4 Safety functions of gas supply system

**9.4.1** Fuel storage tank inlets and outlets shall be provided with valves located as close to the tank as possible. Valves required to be operated during normal operation<sup>2)</sup> which are not accessible shall be remotely operated. Tank valves whether accessible or not shall be automatically operated when the safety system required in 15.2.2 is activated.

**9.4.2** The main gas supply line to each gas consumer or set of consumers shall be equipped with a manually operated stop valve and an automatically operated "master gas fuel valve" coupled in series or a combined manually and automatically operated valve. The valves shall be situated in the part of the piping that is outside the machinery space containing gas consumers, and placed as near as possible to the installation for heating the gas, if fitted. The master gas fuel valve shall automatically cut off the gas supply when activated by the safety system required in 15.2.2.

**9.4.3** The automatic master gas fuel valve shall be operable from safe locations on escape routes inside a machinery space containing a gas consumer, the engine control room, if applicable; outside the machinery space, and from the navigation bridge.

**9.4.4** Each gas consumer shall be provided with "double block and bleed" valves arrangement. These valves shall be arranged as outlined in .1 or .2 so that when the safety system required in 15.2.2 is activated this will cause the shut off valves that are in series to close automatically and the bleed valve to open automatically and:

.1 the two shut-off valves shall be in series in the gas fuel pipe to the gas consuming equipment. The bleed valve shall be in a pipe that vents to a safe location in the open air that portion of the gas fuel piping that is between the two valves in series; or

.2 the function of one of the shut off valves in series and the bleed valve can be incorporated into one valve body, so arranged that the flow to the gas utilization unit will be blocked and the ventilation opened.

**9.4.5** The two valves shall be of the fail-to-close type, while the ventilation valve shall be fail-to-open.

**9.4.6** The double block and bleed valves shall also be used for normal stop of the engine.

**9.4.7** In cases where the master gas fuel valve is automatically shut-down, the complete gas supply branch downstream of the double block and bleed valve shall be automatically ventilated assuming reverse flow from the engine to the pipe.

**9.4.8** There shall be one manually operated shutdown valve in the gas supply line to each engine upstream of the double block and bleed valves to assure safe isolation during maintenance on the engine.

**9.4.9** For single-engine installations and multi-engine installations, where a separate master valve is provided for each engine, the master gas fuel valve and the double block and bleed valve functions can be combined.

**9.4.10** For each main gas supply line entering an ESD protected machinery space, and each gas supply line to high pressure installations means shall be provided for rapid detection of a rupture in the gas line in the engine-room. When rupture is detected a valve shall be automatically shut off<sup>3)</sup>. This valve shall be located in the gas supply line before it enters the engine-room or as close as possible to the point of entry inside the engine-room. It can be a separate valve or combined with other functions, e.g. the master valve.

## 9.5 Fuel distribution outside of machinery space

**9.5.1** Where fuel pipes pass through enclosed spaces in the ship, they shall be protected by a secondary enclosure. This enclosure can be a ventilated duct or a double wall piping system. The duct or double wall piping system shall be mechanically under pressure ventilated with 30 air changes per hour, and gas detection as required in 15.8 shall be provided. Other solutions providing an equivalent safety level may also be accepted by the BKI.

<sup>2)</sup> Normal operation in this context is when gas is supplied to consumers and during bunkering operations

<sup>3)</sup> The shutdown shall be time delayed to prevent shutdown due to transient load variations.

**9.5.2** The requirement in 9.5.1 need not be applied for fully welded fuel gas vent pipes led through mechanically ventilated spaces.

**9.5.3** The requirements in 9.5.4 to 9.5.6 shall apply to ships constructed on or after 1 January 2024 in lieu of the requirements in 9.5.1 and 9.5.2.

**9.5.4** Where gaseous fuel pipes pass through enclosed spaces in the ship, they shall be protected by a secondary enclosure. This enclosure can be a ventilated duct or a double wall piping system. The duct or double wall piping system shall be mechanically under pressure ventilated with 30 air changes per hour, and gas detection as required in 15.8 shall be provided. Other solutions providing an equivalent safety level may also be accepted by the BKI.

**9.5.5** The requirement in 9.5.4 need not be applied for fully welded fuel gas vent pipes led through mechanically ventilated spaces.

**9.5.6** Liquefied fuel pipes shall be protected by a secondary enclosure able to contain leakages. If the piping system is in a fuel preparation room or a tank connection space, the BKI may waive this requirement. Where gas detection as required in 15.8.1.2 is not fit for purpose, the secondary enclosures around liquefied fuel pipes shall be provided with leakage detection by means of pressure or temperature monitoring systems, or any combination thereof. The secondary enclosure shall be able to withstand the maximum pressure that may build up in the enclosure in case of leakage from the fuel piping. For this purpose, the secondary enclosure may need to be arranged with a pressure relief system that prevents the enclosure from being subjected to pressures above their design pressures.

## **9.6 Fuel supply to consumers in gas-safe machinery spaces**

**9.6.1** Fuel piping in gas-safe machinery spaces shall be completely enclosed by a double pipe or duct fulfilling one of the following conditions:

**.1** The gas piping shall be a double wall piping system with the gas fuel contained in the inner pipe. The space between the concentric pipes shall be pressurized with inert gas at a pressure greater than the gas fuel pressure. Suitable alarms shall be provided to indicate a loss of inert gas pressure between the pipes. When the inner pipe contains high pressure gas, the system shall be so arranged that the pipe between the master gas valve and the engine is automatically purged with inert gas when the master gas valve is closed; or

**.2** The gas fuel piping shall be installed within a ventilated pipe or duct. The air space between the gas fuel piping and the wall of the outer pipe or duct shall be equipped with mechanical under pressure ventilation having a capacity of at least 30 air changes per hour. This ventilation capacity may be reduced to 10 air changes per hour provided automatic filling of the duct with nitrogen upon detection of gas is arranged for. The fan motors shall comply with the required explosion protection in the installation area. The ventilation outlet shall be covered by a protection screen and placed in a position where no flammable gas-air mixture may be ignited; or

**.3** Other solutions providing an equivalent safety level may also be accepted by the BKI.

**9.6.2** The connecting of gas piping and ducting to the gas injection valves shall be completely covered by the ducting. The arrangement shall facilitate replacement and/or overhaul of injection valves and cylinder covers. The double ducting is also required for all gas pipes on the engine itself, until gas is injected into the chamber<sup>4)</sup>.

## **9.7 Gas fuel supply to consumers in ESD-protected machinery spaces**

**9.7.1** The pressure in the gas fuel supply system shall not exceed 1,0 MPa.

**9.7.2** The gas fuel supply lines shall have a design pressure not less than 1,0 MPa.

<sup>4)</sup> If gas is supplied into the air inlet directly on each individual cylinder during air intake to the cylinder on a low pressure engine, such that a single failure will not lead to release of fuel gas into the machinery space, double ducting may be omitted on the air inlet pipe.

## 9.8 Design of ventilated duct, outer pipe against inner pipe gas leakage

**9.8.1** The design pressure of the outer pipe or duct of fuel systems shall not be less than the maximum working pressure of the inner pipe. Alternatively, for fuel piping systems with a working pressure greater than 1,0 MPa, the design pressure of the outer pipe or duct shall not be less than the maximum built-up pressure arising in the annular space considering the local instantaneous peak pressure in way of any rupture and the ventilation arrangements.

**9.8.2** For high-pressure fuel piping the design pressure of the ducting shall be taken as the higher of the following:

.1 the maximum built-up pressure: static pressure in way of the rupture resulting from the gas flowing in the annular space;

.2 local instantaneous peak pressure in way of the rupture: this pressure shall be taken as the critical pressure given by the following expression:

$$p = p_0 \left( \frac{2}{k+1} \right)^{\frac{k}{k-1}}$$

where:

$p_0$  = maximum working pressure of the inner pipe

$k$  =  $C_p/C_v$  constant pressure specific heat divided by the constant volume specific heat

$k$  = 1,31 for CH<sub>4</sub>

The tangential membrane stress of a straight pipe shall not exceed the tensile strength divided by 1,5 ( $R_m/1,5$ ) when subjected to the above pressures. The pressure ratings of all other piping components shall reflect the same level of strength as straight pipes. As an alternative to using the peak pressure from the above formula, the peak pressure found from representative tests can be used. Test reports shall then be submitted.

**9.8.3** Verification of the strength shall be based on calculations demonstrating the duct or pipe integrity. As an alternative to calculations, the strength can be verified by representative tests.

**9.8.4** For low pressure fuel piping the duct shall be dimensioned for a design pressure not less than the maximum working pressure of the fuel pipes. The duct shall be pressure tested to show that it can withstand the expected maximum pressure at fuel pipe rupture.

## 9.9 Gas compressors and pumps

**9.9.1** If compressors or pumps are driven by shafting passing through a bulkhead or deck, the bulkhead penetration shall be of gastight type.

**9.9.2** Compressors and pumps shall be suitable for their intended purpose. All equipment and machinery shall be such as to be adequately tested to ensure suitability for use within a marine environment. Such items to be considered would include, but not be limited to:

.1 environmental;

.2 shipboard vibrations and accelerations;

.3 effects of pitch, heave and roll motions, etc.; and

**9.9.3** Arrangements shall be made to ensure that under no circumstances liquefied gas can be introduced in the gas control section or gas-fuelled machinery, unless the machinery is designed to operate with gas in liquid state.

**9.9.4** Compressors and pumps shall be fitted with accessories and instrumentation necessary for efficient and reliable function.

## Section 10 Power Generation Including Propulsion and Other Gas Consumer

10.1	Goal . . . . .	10-1
10.2	Functional requirements . . . . .	10-1
10.3	Internal combustion engines of Piston type . . . . .	10-1
10.4	Main and auxiliary boilers . . . . .	10-2
10.5	Gas turbines . . . . .	10-3

### 10.1 Goal

**10.1.1** The goal of this Section is to provide safe and reliable delivery of mechanical, electrical or thermal energy.

**C10.1.1** Fuel in the context of this Section means natural gas, either in its liquefied or gaseous state.

### 10.2 Functional requirements

This Section is related to functional requirements in 3.2.1, 3.2.11, 3.2.13, 3.2.16 and 3.2.17. In particular, the following apply:

- 10.2.1** the exhaust systems shall be configured to prevent any accumulation of un-burnt gaseous fuel;
- 10.2.2** unless designed with the strength to withstand the worst case over pressure due to ignited gas leaks, engine components or systems containing or likely to contain an ignitable gas and air mixture shall be fitted with suitable pressure relief systems. Dependent on the particular engine design this may include the air inlet manifolds and scavenge spaces;
- 10.2.3** the explosion venting shall be led away from where personnel may normally be present; and
- 10.2.4** all gas consumers shall have a separate exhaust system.

### 10.3 Internal combustion engines of Piston type

#### 10.3.1 General

**.1** The exhaust system shall be equipped with explosion relief ventilation sufficiently dimensioned to prevent excessive explosion pressures in the event of ignition failure of one cylinder followed by ignition of the unburned gas in the system.

**.1.1** For ships constructed on or after 1 January 2024, the exhaust system shall be equipped with explosion relief systems unless designed to accommodate the worst case overpressure due to ignited gas leaks or justified by the safety concept of the engine. A detailed evaluation of the potential for unburnt gas in the exhaust system is to be undertaken covering the complete system from the cylinders up to the open end. This detailed evaluation shall be reflected in the safety concept of the engine.

**.2** For engines where the space below the piston is in direct communication with the crankcase a detailed evaluation regarding the hazard potential of fuel gas accumulation in the crankcase shall be carried out and reflected in the safety concept of the engine.

**.3** Each engine other than two-stroke crosshead diesel engines shall be fitted with vent systems independent of other engines for crankcases and sumps.

.4 Where gas can leak directly into the auxiliary system medium (lubricating oil, cooling water), an appropriate means shall be fitted after the engine outlet to extract gas in order to prevent gas dispersion. The gas extracted from auxiliary systems media shall be vented to a safe location in the atmosphere.

.5 For engines fitted with ignition systems, prior to admission of gas fuel, correct operation of the ignition system on each unit shall be verified.

.6 A means shall be provided to monitor and detect poor combustion or misfiring. In the event that it is detected, gas operation may be allowed provided that the gas supply to the concerned cylinder is shut-off and provided that the operation of the engine with one cylinder cut-off is acceptable with respects to torsional vibrations.

.7 For engines starting on fuels covered by these Guidelines, if combustion has not been detected by the engine monitoring system within an engine specific time after the opening of the fuel supply valve, the fuel supply valve shall be automatically shut off. Means to ensure that any un-burnt fuel mixture is purged away from the exhaust system shall be provided.

### 10.3.2 Dual fuel engines

.1 In case of shut-off of the gas fuel supply, the engines shall be capable of continuous operation by oil fuel only without interruption.

.2 An automatic system shall be fitted to change over from gas fuel operation to oil fuel operation and vice versa with minimum fluctuation of the engine power. Acceptable reliability shall be demonstrated through testing. In the case of unstable operation on engines when gas firing, the engine shall automatically change to oil fuel mode. Manual activation of gas system shut down shall always be possible.

.3 In case of a normal stop or an emergency shutdown, the gas fuel supply shall be shut off not later than the ignition source. It shall not be possible to shut off the ignition source without first or simultaneously closing the gas supply to each cylinder or to the complete engine.

### 10.3.3 Gas-only engines

In case of a normal stop or an emergency shutdown, the gas fuel supply shall be shut off not later than the ignition source. It shall not be possible to shut off the ignition source without first or simultaneously closing the gas supply to each cylinder or to the complete engine.

### 10.3.4 Multi-fuel engines

.1 In case of shut-off of one fuel supply, the engines shall be capable of continuous operation by an alternative fuel with minimum fluctuation of the engine power.

.2 An automatic system shall be fitted to change over from one fuel operation to an alternative fuel operation with minimum fluctuation of the engine power. Acceptable reliability shall be demonstrated through testing. In the case of unstable operation on an engine when using a particular fuel, the engine shall automatically change to an alternative fuel mode. Manual activation shall always be possible.

	GAS ONLY		DUAL FUEL	MULTI FUEL
IGNITION MEDIUM	Spark	Pilot fuel	Pilot fuel	N/A
MAIN FUEL	Gas	Gas	Gas and/ or Oil fuel	Gas and/ or Liquid

## 10.4 Main and auxiliary boilers

10.4.1 Each boiler shall have a dedicated forced draught system. A crossover between boiler force draught systems may be fitted for emergency use providing that any relevant safety functions are maintained.



**10.4.2** Combustion chambers and uptakes of boilers shall be designed to prevent any accumulation of gaseous fuel.

**10.4.3** Burners shall be designed to maintain stable combustion under all firing conditions.

**10.4.4** On main/propulsion boilers an automatic system shall be provided to change from gas fuel operation to oil fuel operation without interruption of boiler firing.

**10.4.5** Gas nozzles and the burner control system shall be configured such that gas fuel can only be ignited by an established oil fuel flame, unless the boiler and combustion equipment is designed and approved by the BKI to light on gas fuel.

**10.4.6** There shall be arrangements to ensure that gas fuel flow to the burner is automatically cut off unless satisfactory ignition has been established and maintained.

**10.4.7** On the fuel pipe of each gas burner a manually operated shut-off valve shall be fitted.

**10.4.8** Provisions shall be made for automatically purging the gas supply piping to the burners, by means of an inert gas, after the extinguishing of these burners.

**10.4.9** The automatic fuel changeover system required by [10.4.4](#) shall be monitored with alarms to ensure continuous availability.

**10.4.10** Arrangements shall be made that, in case of flame failure of all operating burners, the combustion chambers of the boilers are automatically purged before relighting.

**10.4.11** Arrangements shall be made to enable the boilers purging sequence to be manually activated.

## 10.5 Gas turbines

**10.5.1** Unless designed with the strength to withstand the worst case over pressure due to ignited gas leaks, pressure relief systems shall be suitably designed and fitted to the exhaust system, taking into consideration of explosions due to gas leaks. Pressure relief systems within the exhaust uptakes shall be lead to a safe location, away from personnel.

**10.5.2** The gas turbine may be fitted in a gas-tight enclosure arranged in accordance with the ESD principle outlined in [5.6](#) and [9.7](#), however a pressure above 1,0 MPa in the gas supply piping may be accepted within this enclosure.

**10.5.3** Gas detection systems and shut down functions shall be as outlined for ESD protected machinery spaces.

**10.5.4** Ventilation for the enclosure shall be as outlined in [Section 13](#) for ESD protected machinery spaces, but shall in addition be arranged with full redundancy (2x100% capacity fans from different electrical circuits).

**10.5.5** For other than single fuel gas turbines, an automatic system shall be fitted to change over easily and quickly from fuel gas operation to fuel oil operation and vice-versa with minimum fluctuation of the engine power.

**10.5.6** Means shall be provided to monitor and detect poor combustion that may lead to unburnt fuel gas in the exhaust system during operation. In the event that it is detected, the fuel gas supply shall be shut down.

**10.5.7** Each turbine shall be fitted with an automatic shutdown device for high exhaust temperatures.

*This page intentionally left blank*

## Section 11 Fire Safety

11.1	Goal . . . . .	11-1
11.2	Functional requirements . . . . .	11-1
11.3	Fire protection . . . . .	11-1
11.4	Fire main . . . . .	11-2
11.5	Water spray system . . . . .	11-2
11.6	Dry chemical powder fire-extinguishing system . . . . .	11-3
11.7	Fire detection and alarm system . . . . .	11-3
11.8	Fuel preparation room fire-extinguishing systems . . . . .	11-3

### 11.1 Goal

The goal of this Section is to provide for fire-protection, detection and fighting for all system components related to the storage, conditioning, transfer and use of natural gas as ship fuel.

**C11.1.1** Fuel in the context of this Section means natural gas, either in its liquefied or gaseous state.

### 11.2 Functional requirements

This Section is related to functional requirements in [3.2.2](#), [3.2.4](#), [3.2.5](#), [3.2.7](#), [3.2.12](#), [3.2.14](#), [3.2.15](#) and [3.2.17](#).

### 11.3 Fire protection

**11.3.1** Any space containing equipment for the fuel preparation such as pumps, compressors, heat exchangers, vaporizers and pressure vessels shall be regarded as a machinery space of category A for fire protection purposes.<sup>1)</sup>

**11.3.2** Any boundary of accommodation spaces, service spaces, control stations, escape routes and machinery spaces, facing fuel tanks on open deck, shall be shielded by A-60 class divisions. The A-60 class divisions shall extend up to the underside of the deck of the navigation bridge. In addition, fuel tanks shall be segregated from cargo in accordance with the requirements of the International Maritime Dangerous Goods (IMDG) Code where the fuel tanks are regarded as bulk packaging. For the purposes of the stowage and segregation requirements of the IMDG Code, a fuel tank on the open deck shall be considered a class 2.1 package.

**11.3.3** The space containing the fuel containment system shall be separated from the machinery spaces of category A or other rooms with high fire risks. The separation shall be done by a cofferdam of at least 900 mm with insulation of A-60 class. When determining the insulation of the space containing the fuel containment system from other spaces with lower fire risks, the fuel containment system shall be considered as a machinery space of category A, in accordance with SOLAS regulation II-2/9. For type C tanks, the fuel storage hold space may be considered as a cofferdam.<sup>2)</sup>

**.1** Notwithstanding the last sentence in [11.3.3](#), for ships constructed on or after 1 January 2024, the fuel storage hold space may be considered as a cofferdam provided that:

**.1.1** the type C tank is not located directly above machinery spaces of category A or other rooms with high fire risk; and

---

<sup>1)</sup> For interpretation refer to [Guidance for Code and Convention Interpretations \(Pt.1, Vol.Y\) Sec.5, GF13](#)

<sup>2)</sup> For interpretation refer to [Guidance for Code and Convention Interpretations \(Pt.1, Vol.Y\) Sec.5, GF17](#)

.1.2 the minimum distance to the A-60 boundary from the outer shell of the type C tank or the boundary of the tank connection space, if any, is not less than 900 mm.

11.3.4 The fuel storage hold space shall not be used for machinery or equipment that may have a fire risk.

11.3.5 The fire protection of fuel pipes led through ro-ro spaces shall be subject to special consideration by the BKI depending on the use and expected pressure in the pipes.

11.3.6 The bunkering station shall be separated by A-60 class divisions towards machinery spaces of category A, accommodation, control stations and high fire risk spaces, except for spaces such as tanks, voids, auxiliary machinery spaces of little or no fire risk, sanitary and similar spaces where the insulation standard may be reduced to class A-0.

11.3.7 If an ESD protected machinery spaces is separated by a single boundary, the boundary shall be of A-60 class division.

#### 11.4 Fire main

11.4.1 The water spray system required below may be part of the fire main system provided that the required fire pump capacity and working pressure are sufficient for the operation of both the required numbers of hydrants and hoses and the water spray system simultaneously.

11.4.2 When the fuel storage tank(s) is located on the open deck, isolating valves shall be fitted in the fire main in order to isolate damaged sections of the fire main. Isolation of a section of fire main shall not deprive the fire line ahead of the isolated section from the supply of water.

#### 11.5 Water spray system

11.5.1 A water spray system shall be installed for cooling and fire prevention to cover exposed parts of fuel storage tank(s) located on open deck.

11.5.2 The water spray system shall also provide coverage for boundaries of the superstructures, compressor rooms, pump-rooms, cargo control rooms, bunkering control stations, bunkering stations and any other normally occupied deck houses that face the storage tank on open decks unless the tank is located 10 metres or more from the boundaries.

11.5.3 The system shall be designed to cover all areas as specified above with an application rate of 10 l/min/m<sup>2</sup> for the largest horizontal projected surfaces and 4 l/min/m<sup>2</sup> for vertical surfaces.

11.5.4 Stop valves shall be fitted in the water spray application main supply line(s), at intervals not exceeding 40 metres, for the purpose of isolating damaged sections. Alternatively, the system may be divided into two or more sections that may be operated independently, provided the necessary controls are located together in a readily accessible position not likely to be inaccessible in case of fire in the areas protected.

11.5.5 The capacity of the water spray pump shall be sufficient to deliver the required amount of water to the hydraulically most demanding area as specified above in the areas protected.

11.5.6 If the water spray system is not part of the fire main system, a connection to the ship's fire main through a stop valve shall be provided.

11.5.7 Remote start of pumps supplying the water spray system and remote operation of any normally closed valves to the system shall be located in a readily accessible position which is not likely to be inaccessible in case of fire in the areas protected.

11.5.8 The nozzles shall be of an approved full bore type and they shall be arranged to ensure an effective distribution of water throughout the space being protected.

## **11.6 Dry chemical powder fire-extinguishing system**

**11.6.1** A permanently installed dry chemical powder fire-extinguishing system shall be installed in the bunkering station area to cover all possible leak points. The capacity shall be at least 3,5 kg/s for a minimum of 45 s. The system shall be arranged for easy manual release from a safe location outside the protected area.

**11.6.2** In addition to any other portable fire extinguishers that may be required elsewhere in IMO instruments, one portable dry powder extinguisher of at least 5 kg capacity shall be located near the bunkering station.

## **11.7 Fire detection and alarm system**

**11.7.1** A fixed fire detection and fire alarm system complying with the Fire Safety Systems Code shall be provided for the fuel storage hold spaces and the ventilation trunk to the tank connection space and in the tank connection space, and for all other rooms of the fuel gas system where fire cannot be excluded.

**11.7.2** Smoke detectors alone shall not be considered sufficient for rapid detection of a fire.

## **11.8 Fuel preparation room fire-extinguishing systems**

For ships constructed on or after 1 January 2024, fuel preparation rooms containing pumps, compressors or other potential ignition sources shall be provided with a fixed fire-extinguishing system complying with the provisions of SOLAS regulation II-2/10.4.1.1 and taking into account the necessary concentrations/application rate required for extinguishing gas fires.

*This page intentionally left blank*

## Section 12 Explosion Prevention

12.1	Goal . . . . .	12-1
12.2	Functional requirements . . . . .	12-1
12.3	General . . . . .	12-1
12.4	Area classification . . . . .	12-1
12.5	Hazardous area zones . . . . .	12-2

### 12.1 Goal

The goal of this Section is to provide for the prevention of explosions and for the limitation of effects from explosion.

**C12.1.1** Fuel in the context of this Section means natural gas, either in its liquefied or gaseous state.

### 12.2 Functional requirements

This Section is related to functional requirements in 3.2.2 to 3.2.5, 3.2.7, 3.2.8, 3.2.12 to 3.2.14 and 3.2.17. In particular, the following apply: The probability of explosions shall be reduced to a minimum by:

- 12.2.1 reducing number of sources of ignition; and
- 12.2.2 reducing the probability of formation of ignitable mixtures.

### 12.3 General

12.3.1 Hazardous areas on open deck and other spaces not addressed in this Section shall be decided based on a recognized standard<sup>1)</sup>. The electrical equipment fitted within hazardous areas shall be according to the same standard.

12.3.2 Electrical equipment and wiring shall in general not be installed in hazardous areas unless essential for operational purposes based on a recognized standard<sup>2)</sup>.

12.3.3 Electrical equipment fitted in an ESD-protected machinery space shall fulfil the following:

- .1 In addition to fire and gas hydrocarbon detectors and fire and gas alarms, lighting and ventilation fans shall be certified safe for hazardous area zone 1; and
- .2 All electrical equipment in a machinery space containing gas-fuelled engines, and not certified for zone 1 shall be automatically disconnected, if gas concentrations above 40% LEL is detected by two detectors in the space containing gas-fuelled consumers.

### 12.4 Area classification

12.4.1 Area classification is a method of analysing and classifying the areas where explosive gas atmospheres may occur. The object of the classification is to allow the selection of electrical apparatus able to be operated safely in these areas.

---

<sup>1)</sup> Refer to IEC standard 60092-502, part 4.4: Tankers carrying flammable liquefied gases as applicable.  
<sup>2)</sup> Refer to IEC standard 60092-502: IEC 60092-502:1999 Electrical Installations in Ships – Tankers – Special Features and IEC 60079-10-1:2008 Explosive atmospheres – Part 10-1: Classification of areas – Explosive gas atmospheres, according to the area classification.

**12.4.2** In order to facilitate the selection of appropriate electrical apparatus and the design of suitable electrical installations, hazardous areas are divided into zones 0, 1 and 2 <sup>3)</sup>.

See also 12.5 below.

**12.4.3** Ventilation ducts shall have the same area classification as the ventilated space.

## 12.5 Hazardous area zones

### 12.5.1 Hazardous area zone 0

This zone includes, but is not limited to the interiors of fuel tanks, any pipework for pressure-relief or other venting systems for fuel tanks, pipes and equipment containing fuel.

### 12.5.2 Hazardous area zone <sup>4)</sup>

This zone includes, but is not limited to:

- .1 tank connection spaces, fuel storage hold spaces <sup>5)</sup> and interbarrier spaces; <sup>6)</sup>
- .2 fuel preparation room arranged with ventilation according to 13.6;
- .3 areas on open deck, or semi-enclosed spaces on deck, within 3 m of any fuel tank outlet, gas or vapour outlet <sup>7)</sup>, bunker manifold valve, other fuel valve, fuel pipe flange, fuel preparation room ventilation outlets and fuel tank openings for pressure release provided to permit the flow of small volumes of gas or vapour mixtures caused by thermal variation;
- .4 areas on open deck or semi-enclosed spaces on deck, within 1,5 m of fuel preparation room entrances, fuel preparation room ventilation inlets and other openings into zone 1 spaces;
- .5 areas on the open deck within spillage coamings surrounding gas bunker manifold valves and 3 m beyond these, up to a height of 2,4 m above the deck;
- .6 enclosed or semi-enclosed spaces in which pipes containing fuel are located, e.g. ducts around fuel pipes, semi-enclosed bunkering stations;
- .7 the ESD-protected machinery space is considered a non-hazardous area during normal operation, but will require equipment required to operate following detection of gas leakage to be certified as suitable for zone 1;
- .8 a space protected by an airlock is considered as non-hazardous area during normal operation, but will require equipment required to operate following loss of differential pressure between the protected space and the hazardous area to be certified as suitable for zone 1; and
- .9 except for type C tanks, an area within 2,4 m of the outer surface of a fuel containment system where such surface is exposed to the weather.

### 12.5.3 Hazardous area zone <sup>8)</sup>

- .1 This zone includes, but is not limited to areas within 1,5 m surrounding open or semi-enclosed spaces of zone 1.
- .2 Space containing bolted hatch to tank connection space.

<sup>3)</sup> Refer to standards IEC 60079-10-1:2008 Explosive atmospheres part 10-1: Classification of areas – Explosive gas atmospheres and guidance and informative examples given in IEC 60092-502:1999, Electrical Installations in Ships – Tankers – Special Features for tankers.

<sup>4)</sup> Instrumentation and electrical apparatus installed within these areas should be of a type suitable for zone 1.

<sup>5)</sup> Fuel storage hold spaces for type C tanks are normally not considered as zone 1

<sup>6)</sup> For interpretation refer to [Guidance for Code and Convention Interpretations \(Pt.1, Vol.Y\) Sec.5, GF14](#)

<sup>7)</sup> Such areas are, for example, all areas within 3 m of fuel tank hatches, ullage openings or sounding pipes for fuel tanks located on open deck and gas vapour outlets.

<sup>8)</sup> Instrumentation and electrical apparatus installed within these areas should be of a type suitable for zone 2.



## Section 13 Ventilation

13.1	Goal . . . . .	13-1
13.2	Functional requirements . . . . .	13-1
13.3	General . . . . .	13-1
13.4	Tank connection space . . . . .	13-2
13.5	Requirements for machinery spaces . . . . .	13-3
13.6	Requirements for fuel preparation room . . . . .	13-3
13.7	Requirements for bunkering station . . . . .	13-3
13.8	Requirements for ducts and double pipes . . . . .	13-3

### 13.1 Goal

The goal of this Section is to provide for the ventilation required for safe operation of gas-fuelled machinery and equipment.

**C13.1.1** Fuel in the context of this Section means natural gas, either in its liquefied or gaseous state.

### 13.2 Functional requirements

This Section is related to functional requirements in [3.2.2](#), [3.2.5](#), [3.2.8](#), [3.2.10](#), [3.2.12](#) to [3.2.14](#) and [3.2.17](#).

### 13.3 General

**13.3.1** Any ducting used for the ventilation of hazardous spaces shall be separate from that used for the ventilation of non-hazardous spaces. The ventilation shall function at all temperatures and environmental conditions the ship will be operating in.

**13.3.2** Electric motors for ventilation fans shall not be located in ventilation ducts for hazardous spaces unless the motor is certified for the same hazard zone as the space served.

**13.3.3** Design of ventilation fans serving spaces containing gas sources shall fulfil the following:

**.1** Ventilation fans shall not produce a source of vapour ignition in either the ventilated space or the ventilation system associated with the space. Ventilation fans and fan ducts, in way of fans only, shall be of non-sparking construction defined as:

**.1.1** impellers or housings of non-metallic material, due regard being paid to the elimination of static electricity;

**.1.2** impellers and housings of non-ferrous metals;

**.1.3** impellers and housing of austenitic stainless steel;

**.1.4** impellers of aluminium alloys or magnesium alloys and a ferrous (including austenitic stainless steel) housing on which a ring of suitable thickness of non-ferrous materials is fitted in way of the impeller, due regard being paid to static electricity and corrosion between ring and housing; or

**.1.5** any combination of ferrous (including austenitic stainless steel) impellers and housings with not less than 13 mm tip design clearance.

**.2** In no case shall the radial air gap between the impeller and the casing be less than 0,1 of the diameter of the impeller shaft in way of the bearing but not less than 2 mm. The gap need not be more than 13 mm.

.3 Any combination of an aluminium or magnesium alloy fixed or rotating component and a ferrous fixed or rotating component, regardless of tip clearance, is considered a sparking hazard and shall not be used in these places.

**13.3.4** Ventilation systems required to avoid any gas accumulation shall consist of independent fans, each of sufficient capacity, unless otherwise specified in these Guidelines.

**13.3.5** Air inlets for hazardous enclosed spaces shall be taken from areas that, in the absence of the considered inlet, would be non-hazardous. Air inlets for non-hazardous enclosed spaces shall be taken from non-hazardous areas at least 1,5 m away from the boundaries of any hazardous area. Where the inlet duct passes through a more hazardous space, the duct shall be gas-tight and have over-pressure relative to this space.

**13.3.6** Air outlets from non-hazardous spaces shall be located outside hazardous areas.

**13.3.7** Air outlets from hazardous enclosed spaces shall be located in an open area that, in the absence of the considered outlet, would be of the same or lesser hazard than the ventilated space.

**13.3.8** The required capacity of the ventilation plant is normally based on the total volume of the room. An increase in required ventilation capacity may be necessary for rooms having a complicated form.

**13.3.9** Non-hazardous spaces with entry openings to a hazardous area shall be arranged with an air-lock and be maintained at overpressure relative to the external hazardous area. The overpressure ventilation shall be arranged according to the following:

.1 During initial start-up or after loss of overpressure ventilation, before energizing any electrical installations not certified safe for the space in the absence of pressurization, it shall be required to:

.1.1 proceed with purging (at least 5 air changes) or confirm by measurements that the space is non-hazardous; and

.1.2 pressurize the space.

.2 Operation of the overpressure ventilation shall be monitored and in the event of failure of the overpressure ventilation:

.2.1 an audible and visual alarm shall be given at a manned location; and

.2.2 if overpressure cannot be immediately restored, automatic or programmed, disconnection of electrical installations according to a recognized standard<sup>1)</sup> shall be required.

**13.3.10** Non-hazardous spaces with entry openings to a hazardous enclosed space shall be arranged with an airlock and the hazardous space shall be maintained at under pressure relative to the non-hazardous space. Operation of the extraction ventilation in the hazardous space shall be monitored and in the event of failure of the extraction ventilation:

.1 an audible and visual alarm shall be given at a manned location; and

.2 if under pressure cannot be immediately restored, automatic or programmed, disconnection of electrical installations according to a recognized standard in the non-hazardous space shall be required.

## 13.4 Tank connection space

**13.4.1** The tank connection space shall be provided with an effective mechanical forced ventilation system of extraction type. A ventilation capacity of at least 30 air changes per hour shall be provided. The rate of air changes may be reduced if other adequate means of explosion protection are installed. The equivalence of alternative installations shall be demonstrated by a risk assessment.

**13.4.2** Approved automatic fail-safe fire dampers shall be fitted in the ventilation trunk for tank connection space.

<sup>1)</sup> Refer to IEC 60092-502:1999 Electrical Installations in Ships – Tankers – Special Features, table 5

### 13.5 Requirements for machinery spaces

**13.5.1** The ventilation system for machinery spaces containing gas-fuelled consumers shall be independent of all other ventilation systems. <sup>2)</sup>

**13.5.2** ESD protected machinery spaces shall have ventilation with a capacity of at least 30 air changes per hour. The ventilation system shall ensure a good air circulation in all spaces, and in particular ensure that any formation of gas pockets in the room are detected. As an alternative, arrangements whereby under normal operation the machinery spaces are ventilated with at least 15 air changes an hour is acceptable provided that, if gas is detected in the machinery space, the number of air changes will automatically be increased to 30 an hour.

**13.5.3** For ESD protected machinery spaces the ventilation arrangements shall provide sufficient redundancy to ensure a high level of ventilation availability as defined in a standard acceptable to the Organization<sup>3)</sup>.

**13.5.4** The number and power of the ventilation fans for ESD protected engine-rooms and for double pipe ventilation systems for gas safe engine-rooms shall be such that the capacity is not reduced by more than 50% of the total ventilation capacity if a fan with a separate circuit from the main switchboard or emergency switchboard or a group of fans with common circuit from the main switchboard or emergency switchboard, is inoperable.

### 13.6 Requirements for fuel preparation room

**13.6.1** Fuel preparation rooms, shall be fitted with effective mechanical ventilation system of the under pressure type, providing a ventilation capacity of at least 30 air changes per hour.

**13.6.2** The number and power of the ventilation fans shall be such that the capacity is not reduced by more than 50%, if a fan with a separate circuit from the main switchboard or emergency switchboard or a group of fans with common circuit from the main switchboard or emergency switchboard, is inoperable.

**13.6.3** Ventilation systems for fuel preparation rooms, shall be in operation when pumps or compressors are working.

### 13.7 Requirements for bunkering station

Bunkering stations that are not located on open deck shall be suitably ventilated to ensure that any vapour being released during bunkering operations will be removed outside. If the natural ventilation is not sufficient, mechanical ventilation shall be provided in accordance with the risk assessment required by [8.3.1.1](#).

### 13.8 Requirements for ducts and double pipes

**13.8.1** Ducts and double pipes containing fuel piping shall be fitted with effective mechanical ventilation system of the extraction type, providing a ventilation capacity of at least 30 air changes per hour. This is not applicable to double pipes in the engine-room if fulfilling [9.6.1.1](#).

**13.8.2** The ventilation system for double piping and for gas valve unit spaces in gas safe engine-rooms shall be independent of all other ventilation systems.<sup>4)</sup>

**13.8.3** The ventilation inlet for the double wall piping or duct shall always be located in a non-hazardous area away from ignition sources. The inlet opening shall be fitted with a suitable wire mesh guard and protected from ingress of water.<sup>5)</sup>

<sup>2)</sup> For interpretation refer to [Guidance for Code and Convention Interpretations \(Pt.1, Vol.Y\) Sec.5, GF10](#)

<sup>3)</sup> Refer to IEC 60079-10-1

<sup>4)</sup> For interpretation refer to [Guidance for Code and Convention Interpretations \(Pt.1, Vol.Y\) Sec.5, GF11](#)

<sup>5)</sup> For interpretation refer to [Guidance for Code and Convention Interpretations \(Pt.1, Vol.Y\) Sec.5, GF12](#)

**13.8.4** The capacity of the ventilation for a pipe duct or double wall piping may be below 30 air changes per hour if a flow velocity of minimum 3 m/s is ensured. The flow velocity shall be calculated for the duct with fuel pipes and other components installed.

## Section 14 Electrical Installations

14.1	Goal . . . . .	14-1
14.2	Functional requirements . . . . .	14-1
14.3	General . . . . .	14-1

### 14.1 Goal

The goal of this Section is to provide for electrical installations that minimizes the risk of ignition in the presence of a flammable atmosphere.

**C14.1.1** Fuel in the context of this Section means natural gas, either in its liquefied or gaseous state.

### 14.2 Functional requirements

This Section is related to functional requirements in 3.2.1, 3.2.2, 3.2.4, 3.2.7, 3.2.8, 3.2.11, 3.2.13 and 3.2.16 to 3.2.18. In particular, the following apply:

Electrical generation and distribution systems, and associated control systems, shall be designed such that a single fault will not result in the loss of ability to maintain fuel tank pressures and hull structure temperature within normal operating limits.

### 14.3 General

**14.3.1** Electrical installation shall be in compliance with a standard at least equivalent to those acceptable to the Organization<sup>1)</sup>.

**14.3.2** Electrical equipment or wiring shall not be installed in hazardous areas unless essential for operational purposes or safety enhancement.

**14.3.3** Where electrical equipment is installed in hazardous areas as provided in 14.3.2 it shall be selected, installed and maintained in accordance with standards at least equivalent to those acceptable to the Organization<sup>2)</sup>. Equipment for hazardous areas shall be evaluated and certified or listed by an accredited testing authority or notified body recognized by the BKI.

**14.3.4** Failure modes and effects of single failure for electrical generation and distribution systems in 14.2 shall be analysed and documented to be at least equivalent to those acceptable to the Organization<sup>3)</sup>.

**14.3.5** The lighting system in hazardous areas shall be divided between at least two branch circuits. All switches and protective devices shall interrupt all poles or phases and shall be located in a non-hazardous area.

**14.3.6** The installation on board of the electrical equipment units shall be such as to ensure the safe bonding to the hull of the units themselves.

**14.3.7** Arrangements shall be made to alarm in low-liquid level and automatically shut down the motors in the event of low-low liquid level. The automatic shutdown may be accomplished by sensing low pump discharge pressure, low motor current, or low liquid level. This shutdown shall give an audible and visual alarm on the navigation bridge, continuously manned central control station or onboard safety centre.

---

<sup>1)</sup> Refer to IEC 60092 series standards, as applicable.

<sup>2)</sup> Refer to the recommendation published by the International Electrotechnical Commission, in particular to publication IEC 60092-502:1999.

<sup>3)</sup> Refer to IEC 60812

**14.3.8** Submerged fuel pump motors and their supply cables may be fitted in liquefied gas fuel containment systems. Fuel pump motors shall be capable of being isolated from their electrical supply during gas-freeing operations.

**14.3.9** For non-hazardous spaces with access from hazardous open deck where the access is protected by an airlock, electrical equipment which is not of the certified safe type shall be de-energized upon loss of overpressure in the space.

**14.3.10** Electrical equipment for propulsion, power generation, manoeuvring, anchoring and mooring, as well as emergency fire pumps, that are located in spaces protected by airlocks, shall be of a certified safe type.

## Section 15 Control, Monitoring and Safety Systems

15.1	Goal . . . . .	15-1
15.2	Functional requirements . . . . .	15-1
15.3	General . . . . .	15-1
15.4	Bunkering and liquefied gas fuel tank monitoring . . . . .	15-2
15.5	Bunkering control . . . . .	15-3
15.6	Gas compressor monitoring . . . . .	15-3
15.7	Gas engine monitoring . . . . .	15-3
15.8	Gas detection . . . . .	15-4
15.9	Fire detection . . . . .	15-5
15.10	Ventilation . . . . .	15-7
15.11	Safety functions of fuel supply systems . . . . .	15-7

### 15.1 Goal

The goal of this Section is to provide for the arrangement of control, monitoring and safety systems that support an efficient and safe operation of the gas-fuelled installation as covered in the other Sections of these Guidelines.

**C15.1.1** Fuel in the context of this Section means natural gas, either in its liquefied or gaseous state.

### 15.2 Functional requirements

This Section is related to functional requirements in 3.2.1, 3.2.2, 3.2.11, 3.2.13 to 3.2.15, 3.2.17 and 3.2.18. In particular, the following apply:

**15.2.1** the control, monitoring and safety systems of the gas-fuelled installation shall be so arranged that the remaining power for propulsion and power generation is in accordance with 9.3.1 in the event of single failure;

**15.2.2** a gas safety system shall be arranged to close down the gas supply system automatically, upon failure in systems as described in Table 15.1 and upon other fault conditions which may develop too fast for manual intervention;

**15.2.3** for ESD protected machinery configurations the safety system shall shut down gas supply upon gas leakage and in addition disconnect all non-certified safe type electrical equipment in the machinery space;

**15.2.4** the safety functions shall be arranged in a dedicated gas safety system that is independent of the gas control system in order to avoid possible common cause failures. This includes power supplies and input and output signal;

**15.2.5** the safety systems including the field instrumentation shall be arranged to avoid spurious shutdown, e.g. as a result of a faulty gas detector or a wire break in a sensor loop; and

**15.2.6** where two or more gas supply systems are required to meet the regulations, each system shall be fitted with its own set of independent gas control and gas safety systems.

### 15.3 General

**15.3.1** Suitable instrumentation devices shall be fitted to allow a local and a remote reading of essential parameters to ensure a safe management of the whole fuel-gas equipment including bunkering.

**15.3.2** A bilge well in each tank connection space of an independent liquefied gas storage tank shall be provided with both a level indicator and a temperature sensor. Alarm shall be given at high level in the bilge well. Low temperature indication shall activate the safety system.<sup>1)</sup>

**15.3.3** For tanks not permanently installed in the vessel a monitoring system shall be provided as for permanently installed tanks.

## **15.4 Bunkering and liquefied gas fuel tank monitoring**

### **15.4.1 Level indicators for liquefied gas fuel tanks**

.1 Each liquefied gas fuel tank shall be fitted with liquid level gauging device(s), arranged to ensure a level reading is always obtainable whenever the liquefied gas fuel tank is operational. The device(s) shall be designed to operate throughout the design pressure range of the liquefied gas fuel tank and at temperatures within the fuel operating temperature range.

.2 Where only one liquid level gauge is fitted it shall be arranged so that it can be maintained in an operational condition without the need to empty or gas-free the tank.

.3 Liquefied gas fuel tank liquid level gauges may be of the following types:

.3.1 indirect devices, which determine the amount of fuel by means such as weighing or in-line flow metering; or

.3.2 closed devices, which do not penetrate the liquefied gas fuel tank, such as devices using radio-isotopes or ultrasonic devices;

### **15.4.2 Overflow control**

.1 Each liquefied gas fuel tank shall be fitted with a high liquid level alarm operating independently of other liquid level indicators and giving an audible and visual warning when activated.

.2 An additional sensor operating independently of the high liquid level alarm shall automatically actuate a shutoff valve in a manner that will both avoid excessive liquid pressure in the bunkering line and prevent the liquefied gas fuel tank from becoming liquid full.

.3 The position of the sensors in the liquefied gas fuel tank shall be capable of being verified before commissioning. At the first occasion of full loading after delivery and after each dry-docking<sup>2)</sup>, testing of high level alarms shall be conducted by raising the fuel liquid level in the liquefied gas fuel tank to the alarm point.

.4 All elements of the level alarms, including the electrical circuit and the sensor(s), of the high, and overflow alarms, shall be capable of being functionally tested. Systems shall be tested prior to fuel operation in accordance with 18.4.3.

.5 Where arrangements are provided for overriding the overflow control system, they shall be such that inadvertent operation is prevented. When this override is operated continuous visual indication is to be provided at the navigation bridge, continuously manned central control station or onboard safety centre.

**15.4.3** The vapour space of each liquefied gas fuel tank shall be provided with a direct reading gauge. Additionally, an indirect indication is to be provided on the navigation bridge, continuously manned central control station or onboard safety centre.

**15.4.4** The pressure indicators shall be clearly marked with the highest and lowest pressure permitted in the liquefied gas fuel tank.

<sup>1)</sup> For interpretation refer to [Guidance for Code and Convention Interpretations \(Pt.1, Vol.Y\) Sec.5, GF18](#)

<sup>2)</sup> The interpretation of "each dry-docking" should be follow with [Guidance for Code and Convention Interpretations \(Pt.1, Vol.Y\) Sec.5, GF1](#)



**15.4.5** A high-pressure alarm and, if vacuum protection is required, a low-pressure alarm shall be provided on the navigation bridge and at continuously manned central control station or onboard safety centre. Alarms shall be activated before the set pressures of the safety valves are reached.

**15.4.6** Each fuel pump discharge line and each liquid and vapour fuel manifold shall be provided with at least one local pressure indicator.

**15.4.7** Local-reading manifold pressure indicator shall be provided to indicate the pressure between ship's manifold valves and hose connections to the shore.

**15.4.8** Fuel storage hold spaces and interbarrier spaces without open connection to the atmosphere shall be provided with pressure indicator.

**15.4.9** At least one of the pressure indicators provided shall be capable of indicating throughout the operating pressure range.

**15.4.10** For submerged fuel-pump motors and their supply cables, arrangements shall be made to alarm in low liquid level and automatically shut down the motors in the event of low-low liquid level. The automatic shutdown may be accomplished by sensing low pump discharge pressure, low motor current, or low liquid level. This shutdown shall give an audible and visual alarm on the navigation bridge, continuously manned central control station or onboard safety centre.

**15.4.11** Except for independent tanks of type C supplied with vacuum insulation system and pressure build-up fuel discharge unit, each fuel tank shall be provided with devices to measure and indicate the temperature of the fuel in at least three locations; at the bottom and middle of the tank as well as the top of the tank below the highest allowable liquid level.

## **15.5 Bunkering control**

**15.5.1** Control of the bunkering shall be possible from a safe location remote from the bunkering station. At this location the tank pressure, tank temperature if required by 15.4.11, and tank level shall be monitored. Remotely controlled valves required by 8.5.3 and 11.5.7 shall be capable of being operated from this location. Overfill alarm and automatic shutdown shall also be indicated at this location.

**15.5.2** If the ventilation in the ducting enclosing the bunkering lines stops, an audible and visual alarm shall be provided at the bunkering control location, see also 15.8.

**15.5.3** If gas is detected in the ducting around the bunkering lines an audible and visual alarm and emergency shutdown shall be provided at the bunkering control location.

## **15.6 Gas compressor monitoring**

**15.6.1** Gas compressors shall be fitted with audible and visual alarms both on the navigation bridge and in the engine control room. As a minimum the alarms shall include low gas input pressure, low gas output pressure, high gas output pressure and compressor operation.

**15.6.2** Temperature monitoring for the bulkhead shaft glands and bearings shall be provided, which automatically give a continuous audible and visual alarm on the navigation bridge or in a continuously manned central control station.

## **15.7 Gas engine monitoring**

In addition to the instrumentation provided in accordance with part C of SOLAS chapter II-1, indicators shall be fitted on the navigation bridge, the engine control room and the manoeuvring platform for:

**15.7.1** operation of the engine in case of gas-only engines; or

**15.7.2** operation and mode of operation of the engine in the case of dual fuel engines.

## 15.8 Gas detection

**15.8.1** Permanently installed gas detectors shall be fitted in:

- .1 the tank connection spaces;
- .2 all ducts around fuel pipes;
- .3 machinery spaces containing gas piping, gas equipment or gas consumers;
- .4 compressor rooms and fuel preparation rooms;
- .5 other enclosed spaces containing fuel piping or other fuel equipment without ducting;
- .6 other enclosed or semi-enclosed spaces where fuel vapours may accumulate including interbarrier spaces and fuel storage hold spaces of independent tanks other than type C;
- .7 airlocks;
- .8 gas heating circuit expansion tanks;
- .9 motor rooms associated with the fuel systems; and
- .10 or at ventilation inlets to accommodation and machinery spaces if required based on the risk assessment required in 4.2.

**15.8.2** In each ESD-protected machinery space, redundant gas detection systems shall be provided.

**15.8.3** The number of detectors in each space shall be considered taking into account the size, layout and ventilation of the space.

**15.8.4** The detection equipment shall be located where gas may accumulate and in the ventilation outlets. Gas dispersal analysis or a physical smoke test shall be used to find the best arrangement.

**15.8.5** Gas detection equipment shall be designed, installed and tested in accordance with a recognized standard<sup>3)</sup>.

**15.8.6** An audible and visible alarm shall be activated at a gas vapour concentration of 20% of the lower explosion limit (LEL). The safety system shall be activated at 40% of LEL at two detectors (see footnote 1 in [Table 15.1](#)).

**15.8.7** For ventilated ducts around gas pipes in the machinery spaces containing gas-fuelled engines, the alarm limit can be set to 30% LEL. The safety system shall be activated at 60% of LEL at two detectors (see footnote 1 in [Table 15.1](#)).

**15.8.8** Audible and visible alarms from the gas detection equipment shall be located on the navigation bridge or in the continuously manned central control station.

**15.8.9** Gas detection required by this section shall be continuous without delay.

---

<sup>3)</sup> Refer to IEC 60079-29-1 - Explosive atmospheres - Gas detectors - Performance requirements of detectors for flammable detectors.

## 15.9 Fire detection

Required safety actions at fire detection in the machinery space containing gas-fuelled engines and rooms containing independent tanks for fuel storage hold spaces are given in [Table 15.1](#) below.

**Table 15.1: Monitoring of gas supply system to engines**

Parameter	Alarm	Automatic shutdown of tank valve <sup>6)</sup>	Automatic shutdown of gas supply to machinery space containing gas-fuelled engines	Comments
Gas detection in tank connection space at 20% LEL	X			
Gas detection on two detectors <sup>1)</sup> in tank connection space at 40% LEL	X	X		
Fire detection in fuel storage hold space	X			
Fire detection in ventilation trunk to the tank connection space and in the tank connection space	X			
Bilge well high level tank connection space	X			
Bilge well low temperature in tank connection space	X	X		
Gas detection in duct between tank and machinery space containing gas-fuelled engines at 20% LEL	X			
Gas detection on two detectors <sup>1)</sup> in duct between tank and machinery space containing gas-fuelled engines at 40% LEL	X	X <sup>2)</sup>		
Gas detection in fuel preparation room at 20% LEL	X			
Gas detection on two detectors <sup>1)</sup> in fuel preparation room at 40% LEL	X	X <sup>2)</sup>		
Gas detection in duct inside machinery space containing gas-fuelled engines at 30% LEL	X			If double pipe fitted in machinery space containing gas-fuelled engines
Gas detection on two detectors <sup>1)</sup> in duct inside machinery space containing gas-fuelled engines at 60% LEL	X		X <sup>3)</sup>	If double pipe fitted in machinery space containing gas-fuelled engines
Gas detection in ESD protected machinery space containing gas-fuelled engines at 20% LEL	X			

**Table 15.1: Monitoring of gas supply system to engines**  
(continued)

Parameter	Alarm	Automatic shutdown of tank valve <sup>6)</sup>	Automatic shutdown of gas supply to machinery space containing gas-fuelled engines	Comments
Gas detection on two detectors <sup>2)</sup> in ESD protected machinery space containing gas-fuelled engines at 40% LEL	X		X	It shall also disconnect non certified safe electrical equipment in machinery space containing gas-fuelled engines
Loss of ventilation in duct between tank and machinery space containing gas-fuelled engines	X		X <sup>2)</sup>	
Loss of ventilation in duct inside machinery space containing gas-fuelled engines <sup>5)</sup>	X		X <sup>3)</sup>	If double pipe fitted in machinery space containing gas-fuelled engines
Loss of ventilation in ESD protected machinery space containing gas-fuelled engines	X		X	
Fire detection in machinery space containing gas-fuelled engines	X			
Abnormal gas pressure in gas supply pipe	X			
Failure of valve control actuating medium	X		X <sup>4)</sup>	Time delayed as found necessary
Automatic shutdown of engine (engine failure)	X		X <sup>4)</sup>	
Manually activated emergency shutdown of engine	X		X	

1) Two independent gas detectors located close to each other are required for redundancy reasons. If the gas detector is of self-monitoring type the installation of a single gas detector can be permitted.

2) If the tank is supplying gas to more than one engine and the different supply pipes are completely separated and fitted in separate ducts and with the master valves fitted outside of the duct, only the master valve on the supply pipe leading into the duct where gas or loss of ventilation is detected shall close.

3) If the gas is supplied to more than one engine and the different supply pipes are completely separated and fitted in separate ducts and with the master valves fitted outside of the duct and outside of the machinery space containing gas-fuelled engines, only the master valve on the supply pipe leading into the duct where gas or loss of ventilation is detected shall close.

4) Only double block and bleed valves to close.

5) If the duct is protected by inert gas (see 9.6.1.1) then loss of inert gas overpressure shall lead to the same actions as given in this table.

6) Valves referred to in 9.4.1.

## 15.10 Ventilation

**15.10.1** Any loss of the required ventilating capacity shall give an audible and visual alarm on the navigation bridge or in a continuously manned central control station or safety centre.<sup>4)</sup>

**15.10.2** For ESD protected machinery spaces the safety system shall be activated upon loss of ventilation in engine-room.

## 15.11 Safety functions of fuel supply systems

**15.11.1** If the fuel supply is shut off due to activation of an automatic valve, the fuel supply shall not be opened until the reason for the disconnection is ascertained and the necessary precautions taken. A readily visible notice giving instruction to this effect shall be placed at the operating station for the shut-off valves in the fuel supply lines.

**15.11.2** If a fuel leak leading to a fuel supply shutdown occurs, the fuel supply shall not be operated until the leak has been found and dealt with. Instructions to this effect shall be placed in a prominent position in the machinery space.

**15.11.3** A caution placard or signboard shall be permanently fitted in the machinery space containing gas-fuelled engines stating that heavy lifting, implying danger of damage to the fuel pipes, shall not be done when the engine(s) is running on gas.

**15.11.4** Compressors, pumps and fuel supply shall be arranged for manual remote emergency stop from the following locations as applicable:

- .1 navigation bridge;
- .2 cargo control room;
- .3 on-board safety centre;
- .4 engine control room;
- .5 fire control station; and
- .6 adjacent to the exit of fuel preparation rooms.

The gas compressor shall also be arranged for manual local emergency stop.

---

<sup>4)</sup> For interpretation refer to [Guidance for Code and Convention Interpretations \(Pt.1, Vol.Y\) Sec.5, GF15](#)

*This page intentionally left blank*

## Section 16 Manufacture, Workmanship and Testing

16.1	General . . . . .	16-1
16.2	General test regulations and specifications . . . . .	16-1
16.3	Welding of metallic materials and non-destructive testing for the fuel containment system . . . . .	16-3
16.4	Other regulations for construction in metallic materials . . . . .	16-6
16.5	Testing . . . . .	16-6
16.6	Welding, post-weld heat treatment and non-destructive testing . . . . .	16-8
16.7	Testing requirements . . . . .	16-9

### 16.1 General

**16.1.1** The manufacture, testing, inspection and documentation shall be in accordance with recognized standards and the regulations given in these Guidelines.

**16.1.2** Where post-weld heat treatment is specified or required, the properties of the base material shall be determined in the heat treated condition, in accordance with the applicable tables of [Section 7](#), and the weld properties shall be determined in the heat treated condition in accordance with [16.3](#). In cases where a post-weld heat treatment is applied, the test regulations may be modified at the discretion of the BKI.

**C16.1.3** Fuel in the context of this Section means natural gas, either in its liquefied or gaseous state.

### 16.2 General test regulations and specifications

#### 16.2.1 Tensile test

- .1 Tensile testing shall be carried out in accordance with recognized standards.
- .2 Tensile strength, yield stress and elongation shall be to the satisfaction of the BKI. For carbon-manganese steel and other materials with definitive yield points, consideration shall be given to the limitation of the yield to tensile ratio.

#### 16.2.2 Toughness test

.1 Acceptance tests for metallic materials shall include Charpy V-notch toughness tests unless otherwise specified by the BKI. The specified Charpy V-notch regulations are minimum average energy values for three full size (10 mm × 10 mm) specimens and minimum single energy values for individual specimens. Dimensions and tolerances of Charpy V-notch specimens shall be in accordance with recognized standards. The testing and regulations for specimens smaller than 5,0 mm in size shall be in accordance with recognized standards. Minimum average values for sub-sized specimens shall be:

**Table 16.1: Monitoring of gas supply system to engines**

Charpy V-notch specimen size (mm)	Minimum average energy of three specimens
10 x 10	KV
10 x 7,5	5/6 KV
10 x 5,0	2/3 KV

where:

KV = the energy values (J) specified in Table 7.1 to 7.4.

Only one individual value may be below the specified average value, provided it is not less than 70% of that value.

.2 For base metal, the largest size Charpy V-notch specimens possible for the material thickness shall be machined with the specimens located as near as practicable to a point midway between the surface and the centre of the thickness and the length of the notch perpendicular to the surface as shown in Figure 16.2.1.

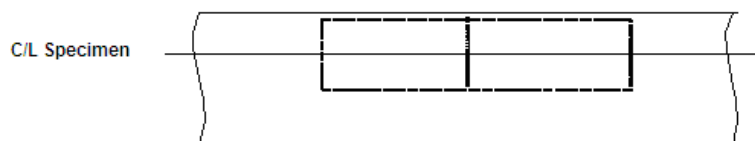

Figure 16.2.1: Orientation of base metal test specimen

.3 For a weld test specimen, the largest size Charpy V-notch specimens possible for the material thickness shall be machined, with the specimens located as near as practicable to a point midway between the surface and the centre of the thickness. In all cases the distance from the surface of the material to the edge of the specimen shall be approximately 1 mm or greater. In addition, for double-V butt welds, specimens shall be machined closer to the surface of the second welded section. The specimens shall be taken generally at each of the following locations, as shown in Figure 16.2.2, on the centreline of the welds, the fusion line and 1 mm, 3 mm and 5 mm from the fusion line.

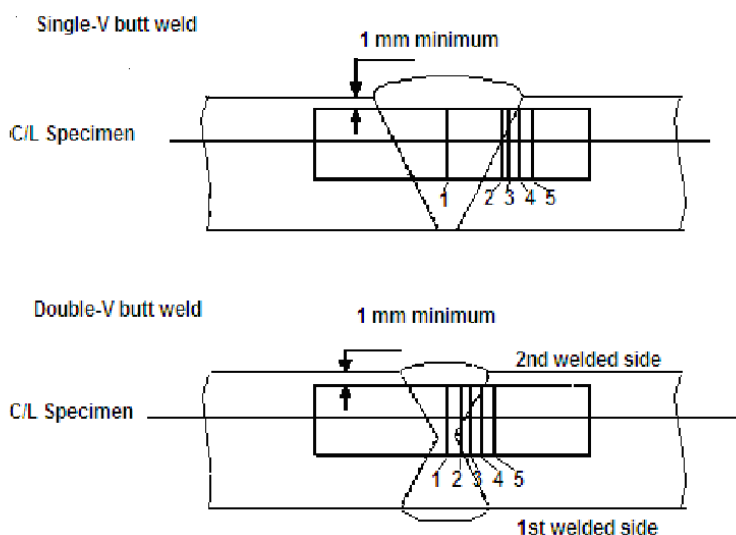

Figure 16.2.2: Orientation of weld test specimen

Notch locations in Figure 16.2.2:

- .3.1 centreline of the weld;
- .3.2 on fusion line;
- .3.3 in heat-affected zone (HAZ), 1 mm from fusion line;
- .3.4 in HAZ, 3 mm from fusion line; and
- .3.5 in HAZ, 5 mm from fusion line.



.4 If the average value of the three initial Charpy V-notch specimens fails to meet the stated regulations, or the value for more than one specimen is below the required average value, or when the value for one specimen is below the minimum value permitted for a single specimen, three additional specimens from the same material may be tested and the results combined with those previously obtained to form a new average. If this new average complies with the regulations and if no more than two individual results are lower, than the required average and no more than one result is lower than the required value for a single specimen, the piece or batch may be accepted.

#### **16.2.3 Bend test**

.1 The bend test may be omitted as a material acceptance test, but is required for weld tests. Where a bend test is performed, this shall be done in accordance with recognized standards.

.2 The bend tests shall be transverse bend tests, which may be face, root or side bends at the discretion of the BKI. However, longitudinal bend tests may be required in lieu of transverse bend tests in cases where the base material and weld metal have different strength levels.

#### **16.2.4 Section observation and other testing**

Macrosection, microsection observations and hardness tests may also be required by the BKI, and they shall be carried out in accordance with recognized standards, where required.

### **16.3 Welding of metallic materials and non-destructive testing for the fuel containment system**

#### **16.3.1 General**

This Section shall apply to primary and secondary barriers only, including the inner hull where this forms the secondary barrier. Acceptance testing is specified for carbon, carbon-manganese, nickel alloy and stainless steels, but these tests may be adapted for other materials. At the discretion of the BKI, impact testing of stainless steel and aluminium alloy weldments may be omitted and other tests may be specially required for any material.

#### **16.3.2 Welding consumables**

Consumables intended for welding of fuel tanks shall be in accordance with recognized standards. Deposited weld metal tests and butt weld tests shall be required for all consumables. The results obtained from tensile and Charpy V-notch impact tests shall be in accordance with recognized standards. The chemical composition of the deposited weld metal shall be recorded for information.

#### **16.3.3 Welding procedure tests for fuel tanks and process pressure vessels**

.1 Welding procedure tests for fuel tanks and process pressure vessels are required for all butt welds.

.2 The test assemblies shall be representative of:

.2.1 each base material;

.2.2 each type of consumable and welding process; and

.2.3 each welding position.

.3 For butt welds in plates, the test assemblies shall be so prepared that the rolling direction is parallel to the direction of welding. The range of thickness qualified by each welding procedure test shall be in accordance with recognized standards. Radiographic or ultrasonic testing may be performed at the option of the fabricator.

.4 The following welding procedure tests for fuel tanks and process pressure vessels shall be done in accordance with 16.2 with specimens made from each test assembly:

- .4.1 cross-weld tensile tests;
- .4.2 longitudinal all-weld testing where required by the recognized standards;
- .4.3 transverse bend tests, which may be face, root or side bends. However, longitudinal bend tests may be required in lieu of transverse bend tests in cases where the base material and weld metal have different strength levels;
- .4.4 one set of three Charpy V-notch impacts, generally at each of the following locations, as shown in [Figure 16.2.2](#):
  - .4.4.1 centreline of the welds;
  - .4.4.2 fusion line;
  - .4.4.3 1 mm from the fusion line;
  - .4.4.4 3 mm from the fusion line; and
  - .4.4.5 5 mm from the fusion line;
- .4.5 macrosection, microsection and hardness survey may also be required.
- .5 Each test shall satisfy the following:
  - .5.1 tensile tests: cross-weld tensile strength is not to be less than the specified minimum tensile strength for the appropriate parent materials. For materials such as aluminium alloys, reference shall be made to [6.4.12.1.1.3](#) with regard to the regulations for weld metal strength of under-matched welds (where the weld metal has a lower tensile strength than the parent metal). In every case, the position of fracture shall be recorded for information;
  - .5.2 bend tests: no fracture is acceptable after a 180° bend over a former of a diameter four times the thickness of the test pieces; and
  - .5.3 Charpy V-notch impact tests: Charpy V-notch tests shall be conducted at the temperature prescribed for the base material being joined. The results of weld metal impact tests, minimum average energy (KV), shall be no less than 27 J. The weld metal regulations for sub-size specimens and single energy values shall be in accordance with [16.2.2](#). The results of fusion line and heat affected zone impact tests shall show a minimum average energy (KV) in accordance with the transverse or longitudinal regulations of the base material, whichever is applicable, and for sub-size specimens, the minimum average energy (KV) shall be in accordance with [16.2.2](#). If the material thickness does not permit machining either full-size or standard sub-size specimens, the testing procedure and acceptance standards shall be in accordance with recognized standards.
- .6 Procedure tests for fillet welding shall be in accordance with recognized standards. In such cases, consumables shall be so selected that exhibit satisfactory impact properties.

#### **16.3.4 Welding procedure tests for piping**

Welding procedure tests for piping shall be carried out and shall be similar to those detailed for fuel tanks in [16.3.3](#).

#### **16.3.5 Production weld tests**

.1 For all fuel tanks and process pressure vessels except membrane tanks, production weld tests shall generally be performed for approximately each 50 m of butt-weld joints and shall be representative of each welding position. For secondary barriers, the same type production tests as required for primary tanks shall be performed, except that the number of tests may be reduced subject to agreement with the BKI. Tests, other than those specified in [16.3.5.2](#) to [16.3.5.5](#) may be required for fuel tanks or secondary barriers.

.2 The production tests for types A and B independent tanks shall include bend tests and, where required for procedure tests, one set of three Charpy V-notch tests. The tests shall be made for each 50 m of weld. The Charpy V-notch tests shall be made with specimens having the notch alternately located in the centre of the weld and in the heat affected zone (most critical location based on procedure qualification results). For austenitic stainless steel, all notches shall be in the centre of the weld.

.3 For type C independent tanks and process pressure vessels, transverse weld tensile tests are required in addition to the tests listed in 16.3.5.2. Tensile tests shall meet regulation 16.3.3.5.

.4 The quality assurance/quality control (QA/QC) program shall ensure the continued conformity of the production welds as defined in the material manufacturers quality manual (QM).

.5 The test regulations for membrane tanks are the same as the applicable test regulations listed in 16.3.3.

#### 16.3.6 Non-destructive testing

.1 All test procedures and acceptance standards shall be in accordance with recognized standards, unless the designer specifies a higher standard in order to meet design assumptions. Radiographic testing shall be used in principle to detect internal defects. However, an approved ultrasonic test procedure in lieu of radiographic testing may be conducted, but in addition supplementary radiographic testing at selected locations shall be carried out to verify the results. Radiographic and ultrasonic testing records shall be retained.

.2 For type A independent tanks where the design temperature is below -20°C, and for type B independent tanks, regardless of temperature, all full penetration butt welds of the shell plating of fuel tanks shall be subjected to non-destructive testing suitable to detect internal defects over their full length. Ultrasonic testing in lieu of radiographic testing may be carried out under the same conditions as described in 16.3.6.1.

.3 In each case the remaining tank structure, including the welding of stiffeners and other fittings and attachments, shall be examined by magnetic particle or dye penetrant methods as considered necessary.

.4 For type C independent tanks, the extent of non-destructive testing shall be total or partial according to recognized standards, but the controls to be carried out shall not be less than the following:

.4.1 Total non-destructive testing referred to in 6.4.15.3.2.1.3

Radiographic testing:

.4.1.1 all butt welds over their full length.

Non-destructive testing for surface crack detection:

.4.1.2 all welds over 10% of their length;

.4.1.3 reinforcement rings around holes, nozzles, etc. over their full length.

As an alternative, ultrasonic testing, as described in 16.3.6.1, may be accepted as a partial substitute for the radiographic testing. In addition, the BKI may require total ultrasonic testing on welding of reinforcement rings around holes, nozzles, etc.

.4.2 Partial non-destructive testing referred to in 6.4.15.3.2.1.3:

Radiographic testing:

.4.2.1 all butt welded crossing joints and at least 10% of the full length of butt welds at selected positions uniformly distributed.

Non-destructive testing for surface crack detection:

.4.2.2 reinforcement rings around holes, nozzles, etc. over their full length.

Ultrasonic testing:

.4.2.3 as may be required by the BKI in each instance.

.5 The quality assurance/quality control (QA/QC) program shall ensure the continued conformity of the non-destructive testing of welds, as defined in the material manufacturer's quality manual (QM).

.6 Inspection of piping shall be carried out in accordance with the regulations of [Section 7](#).

.7 The secondary barrier shall be non-destructive tested for internal defects as considered necessary. Where the outer shell of the hull is part of the secondary barrier, all sheer strake butts and the intersections of all butts and seams in the side shell shall be tested by radiographic testing.

## **16.4 Other regulations for construction in metallic materials**

### **16.4.1 General**

Inspection and non-destructive testing of welds shall be in accordance with regulations in [16.3.5](#) and [16.3.6](#). Where higher standards or tolerances are assumed in the design, they shall also be satisfied.

### **16.4.2 Independent tank**

For type C tanks and type B tanks primarily constructed of bodies of revolution the tolerances relating to manufacture, such as out-of-roundness, local deviations from the true form, welded joints alignment and tapering of plates having different thicknesses, shall comply with recognized standards. The tolerances shall also be related to the buckling analysis referred to in [6.4.15.2.3.1](#) and [6.4.15.3.3.2](#).

### **16.4.3 Secondary barriers**

During construction the regulations for testing and inspection of secondary barriers shall be approved or accepted by the BKI (see also [6.4.4.5](#) and [6.4.4.6](#)).

### **16.4.4 Membrane tanks**

The quality assurance/quality control (QA/QC) program shall ensure the continued conformity of the weld procedure qualification, design details, materials, construction, inspection and production testing of components. These standards and procedures shall be developed during the prototype testing programme.

## **16.5 Testing**

### **16.5.1 Testing and inspections during construction**

.1 All liquefied gas fuel tanks and process pressure vessels shall be subjected to hydrostatic or hydro-pneumatic pressure testing in accordance with [16.5.2](#) to [16.5.5](#), as applicable for the tank type.

.2 All tanks shall be subject to a tightness test which may be performed in combination with the pressure test referred to in [16.5.1.1](#).

.3 The gas tightness of the fuel containment system with reference to [6.3.3](#) shall be tested.

.4 Regulations with respect to inspection of secondary barriers shall be decided by the BKI in each case, taking into account the accessibility of the barrier (see also [6.4.4](#)).

.5 The BKI may require that for ships fitted with novel type B independent tanks, or tanks designed according to [6.4.16](#) at least one prototype tank and its support shall be instrumented with strain gauges or other suitable equipment to confirm stress levels during the testing required in [16.5.1.1](#). Similar instrumentation may be required for type C independent tanks, depending on their configuration and on the arrangement of their supports and attachments.

.6 The overall performance of the fuel containment system shall be verified for compliance with the design parameters during the first LNG bunkering, when steady thermal conditions of the liquefied gas fuel are reached, in accordance with the requirements of the BKI. Records of the performance of the components and equipment, essential to verify the design parameters, shall be maintained on board and be available to the BKI.

.7 The fuel containment system shall be inspected for cold spots during or immediately following the first LNG bunkering, when steady thermal conditions are reached. Inspection of the integrity of thermal insulation surfaces that cannot be visually checked shall be carried out in accordance with the requirements of the BKI.

.8 Heating arrangements, if fitted in accordance with 6.4.13.1.1.3 and 6.4.13.1.1.4, shall be tested for required heat output and heat distribution.

#### 16.5.2 Type A independent tanks

All type A independent tanks shall be subjected to a hydrostatic or hydro-pneumatic pressure testing. This test shall be performed such that the stresses approximate, as far as practicable, the design stresses, and that the pressure at the top of the tank corresponds at least to the MARVS. When a hydro-pneumatic test is performed, the conditions shall simulate, as far as practicable, the design loading of the tank and of its support structure including dynamic components, while avoiding stress levels that could cause permanent deformation.

#### 16.5.3 Type B independent tanks

Type B independent tanks shall be subjected to a hydrostatic or hydro-pneumatic pressure testing as follows:

.1 The test shall be performed as required in 16.5.2 for type A independent tanks.

.2 In addition, the maximum primary membrane stress or maximum bending stress in primary members under test conditions shall not exceed 90% of the yield strength of the material (as fabricated) at the test temperature. To ensure that this condition is satisfied, when calculations indicate that this stress exceeds 75% of the yield strength the test of the first of a series of identical tanks shall be monitored by the use of strain gauges or other suitable equipment.

#### 16.5.4 Type C independent tanks and other pressure vessels

.1 Each pressure vessel shall be subjected to a hydrostatic test at a pressure measured at the top of the tanks, of not less than  $1,5 P_0$ . In no case during the pressure test shall the calculated primary membrane stress at any point exceed 90% of the yield strength of the material at the test temperature. To ensure that this condition is satisfied where calculations indicate that this stress will exceed 0,75 times the yield strength, the test of the first of a series of identical tanks shall be monitored by the use of strain gauges or other suitable equipment in pressure vessels other than simple cylindrical and spherical pressure vessels.

.2 The temperature of the water used for the test shall be at least 30°C above the nil-ductility transition temperature of the material, as fabricated.

.3 The pressure shall be held for 2 hours per 25 mm of thickness, but in no case less than 2 hours.

.4 Where necessary for liquefied gas fuel pressure vessels, a hydro-pneumatic test may be carried out under the conditions prescribed in 16.5.4.1 to 16.5.4.3.

.5 Special consideration may be given to the testing of tanks in which higher allowable stresses are used, depending on service temperature. However, regulation in 16.5.4.1 shall be fully complied with.

.6 After completion and assembly, each pressure vessel and its related fittings shall be subjected to an adequate tightness test, which may be performed in combination with the pressure testing referred to in 16.5.4.1 or 16.5.4.4 as applicable.

.7 Pneumatic testing of pressure vessels other than liquefied gas fuel tanks shall be considered on an individual case basis. Such testing shall only be permitted for those vessels designed or supported such that they cannot be safely filled with water, or for those vessels that cannot be dried and are to be used in a service where traces of the testing medium cannot be tolerated.

#### **16.5.5 Membrane tanks**

##### **.1 Design development testing**

.1.1 The design development testing required in 6.4.15.4.1.2 shall include a series of analytical and physical models of both the primary and secondary barriers, including corners and joints, tested to verify that they will withstand the expected combined strains due to static, dynamic and thermal loads at all filling levels. This will culminate in the construction of a prototype scaled model of the complete liquefied gas fuel containment system. Testing conditions considered in the analytical and physical model shall represent the most extreme service conditions the liquefied gas fuel containment system will be likely to encounter over its life. Proposed acceptance criteria for periodic testing of secondary barriers required in 6.4.4 may be based on the results of testing carried out on the prototype scaled model.

.1.2 The fatigue performance of the membrane materials and representative welded or bonded joints in the membranes shall be determined by tests. The ultimate strength and fatigue performance of arrangements for securing the thermal insulation system to the hull structure shall be determined by analyses or tests.

##### **.2 Testing**

.2.1 In ships fitted with membrane liquefied gas fuel containment systems, all tanks and other spaces that may normally contain liquid and are adjacent to the hull structure supporting the membrane, shall be hydrostatically tested.

.2.2 All hold structures supporting the membrane shall be tested for tightness before installation of the liquefied gas fuel containment system.

.2.3 Pipe tunnels and other compartments that do not normally contain liquid need not be hydrostatically tested.

#### **16.6 Welding, post-weld heat treatment and non-destructive testing**

##### **16.6.1 General**

Welding shall be carried out in accordance with 16.3.

##### **16.6.2 Post-weld heat treatment**

Post-weld heat treatment shall be required for all butt welds of pipes made with carbon, carbon-manganese and low alloy steels. The BKI may waive the regulations for thermal stress relieving of pipes with wall thickness less than 10 mm in relation to the design temperature and pressure of the piping system concerned.

##### **16.6.3 Non-destructive testing**

In addition to normal controls before and during the welding, and to the visual inspection of the finished welds, as necessary for proving that the welding has been carried out correctly and according to the regulations in this paragraph, the following tests shall be required:

- .1 100% radiographic or ultrasonic inspection of butt-welded joints for piping systems with;
  - .1.1 design temperatures colder than minus 10°C; or
  - .1.2 design pressure greater than 1,0 MPa; or

- .1.3 gas supply pipes in ESD protected machinery spaces; or
  - .1.4 inside diameters of more than 75 mm; or
  - .1.5 wall thicknesses greater than 10 mm.
- .2 When such butt welded joints of piping sections are made by automatic welding procedures approved by the BKI, then a progressive reduction in the extent of radiographic or ultrasonic inspection can be agreed, but in no case to less than 10% of each joint. If defects are revealed the extent of examination shall be increased to 100% and shall include inspection of previously accepted welds. This approval can only be granted if well-documented quality assurance procedures and records are available to assess the ability of the manufacturer to produce satisfactory welds consistently.
- .3 The radiographic or ultrasonic inspection regulation may be reduced to 10% for butt-welded joints in the outer pipe of double-walled fuel piping.
- .4 For other butt-welded joints of pipes not covered by 16.6.3.1 and 16.6.3.3, spot radiographic or ultrasonic inspection or other non-destructive tests shall be carried out depending upon service, position and materials. In general, at least 10% of butt-welded joints of pipes shall be subjected to radiographic or ultrasonic inspection.

## 16.7 Testing requirements

### 16.7.1 Type testing of piping components

#### .1 Valves

Each type of piping component intended to be used at a working temperature below minus 55°C shall be subject to the following type tests:

- .1.1 Each size and type of valve shall be subjected to seat tightness testing over the full range of operating pressures and temperatures, at intervals, up to the rated design pressure of the valve. Allowable leakage rates shall be to the requirements of the BKI During the testing satisfactory operation of the valve shall be verified.
- .1.2 The flow or capacity shall be certified to a recognized standard for each size and type of valve.
- .1.3 Pressurized components shall be pressure tested to at least 1,5 times the design pressure.
- .1.4 For emergency shutdown valves, with materials having melting temperatures lower than 925°C, the type testing shall include a fire test to a standard acceptable to the Organization<sup>1)</sup>.

### 16.7.2 Expansion bellows

The following type tests shall be performed on each type of expansion bellows intended for use on fuel piping outside the fuel tank as found acceptable in 7.3.6.4.3.1 and .3 and where required by the BKI, on those installed within the fuel tanks:

- .1 Elements of the bellows, not pre-compressed, but axially restrained shall be pressure tested at not less than five times the design pressure without bursting. The duration of the test shall not be less than five minutes.
- .2 A pressure test shall be performed on a type expansion joint, complete with all the accessories such as flanges, stays and articulations, at the minimum design temperature and twice the design pressure at the extreme displacement conditions recommended by the manufacturer without permanent deformation.

---

<sup>1)</sup> Refer to the recommendations by the International Organization for Standardization, in particular publications, such as ISO 19921:2005, Ships and marine technology – Fire resistance of metallic pipe components with resilient and elastomeric seals – Test methods or ISO 19922:2005, Ships and marine technology – Fire resistance of metallic pipe components with resilient and elastomeric seals – Requirements imposed on the test bench.



.3 A cyclic test (thermal movements) shall be performed on a complete expansion joint, which shall withstand at least as many cycles under the conditions of pressure, temperature, axial movement, rotational movement and transverse movement as it will encounter in actual service. Testing at ambient temperature is permitted when this testing is at least as severe as testing at the service temperature.

.4 A cyclic fatigue test (ship deformation, ship accelerations and pipe vibrations) shall be performed on a complete expansion joint, without internal pressure, by simulating the bellows movement corresponding to a compensated pipe length, for at least 2 000 000 cycles at a frequency not higher than 5 Hz. This test is only required when, due to the piping arrangement, ship deformation loads are actually experienced.

### 16.7.3 System testing requirements

.1 The requirements for testing in this section apply to fuel piping inside and outside the fuel tanks. However, relaxation from these regulations for piping inside fuel tanks and open ended piping may be accepted by the BKI.

.2 After assembly, all fuel piping shall be subjected to a strength test with a suitable fluid. The test pressure shall be at least 1,5 times the design pressure for liquid lines and 1,5 times the maximum system working pressure for vapour lines. When piping systems or parts of systems are completely manufactured and equipped with all fittings, the test may be conducted prior to installation on board the ship. Joints welded on board shall be tested to at least 1,5 times the design pressure.

.3 After assembly on board, the fuel piping system shall be subjected to a leak test using air, or other suitable medium to a pressure depending on the leak detection method applied.

.4 In double wall fuel piping systems the outer pipe or duct shall also be pressure tested to show that it can withstand the expected maximum pressure at pipe rupture.

.5 All piping systems, including valves, fittings and associated equipment for handling fuel or vapours, shall be tested under normal operating conditions not later than at the first bunkering operation, in accordance with the requirements of the BKI.

.6 Emergency shutdown valves in liquefied gas piping systems shall close fully and smoothly within 30 s of actuation. Information about the closure time of the valves and their operating characteristics shall be available on board, and the closing time shall be verifiable and repeatable.

.7 The closing time of the valve referred to in 8.5.8 and 15.4.2.2 (i.e. time from shutdown signal initiation to complete valve closure) shall not be greater than:

$$\frac{3600 U}{BR} \text{ second}$$

Where:

U = ullage volume at operating signal level (m<sup>3</sup>);

BR = maximum bunkering rate agreed between ship and shore facility (m<sup>3</sup>/h); or 5 seconds, whichever smallest.

The bunkering rate shall be adjusted to limit surge pressure on valve closure to an acceptable level, taking into account the bunkering hose or arm, the ship and the shore piping systems, where relevant.



## Section 17 Drills and Emergency Exercises

17.1 Drills and Emergency Exercises . . . . . 17-1

### 17.1 Drills and Emergency Exercises

Drills and emergency exercises on board shall be conducted at regular intervals. Such gas-related exercises could include for example:

- 17.1.1 tabletop exercise;
- 17.1.2 review of fueling procedures based in the fuel handling manual required by 18.2.3;
- 17.1.3 responses to potential contingences;
- 17.1.4 tests of equipment intended for contingency response; and
- 17.1.5 reviews that assigned seafarers are trained to perform assigned duties during fuelling and contingency response.

Gas related exercises may be incorporated into periodical drills required by SOLAS.

The response and safety system for hazards and accident control shall be reviewed and tested.

**C17.2** Fuel in the context of this Section means natural gas, either in its liquefied or gaseous state.

*This page intentionally left blank*

## Section 18 Operation

18.1	General . . . . .	18-1
18.2	Functional requirements . . . . .	18-1
18.3	Maintenance . . . . .	18-1
18.4	Bunkering operations . . . . .	18-2
18.5	Enclosed space entry . . . . .	18-3
18.6	Inerting and purging of fuel systems . . . . .	18-3
18.7	Hot work on or near fuel systems . . . . .	18-4

### 18.1 General

The goal of this Section is to ensure that operational procedures for the loading, storage, operation, maintenance, and inspection of systems for gas or low-flashpoint fuels minimize the risk to personnel, the ship and the environment and that are consistent with practices for a conventional oil fuelled ship whilst taking into account the nature of the liquid or gaseous fuel.

**C18.1.1** Fuel in the context of this Section means natural gas, either in its liquefied or gaseous state.

### 18.2 Functional requirements

This Section relates to the functional requirements in [3.2.1](#) to [3.2.3](#), [3.2.9](#), [3.2.11](#), [3.2.15](#), [3.2.16](#) and [3.2.17](#). In particular, the following apply:

- 18.2.1** a copy of IGF Code, or national regulations incorporating the provisions of these Guidelines, shall be on board every ship covered by IGF Code;
- 18.2.2** maintenance procedures and information for all gas related installations shall be available on board;
- 18.2.3** the ship shall be provided with operational procedures including a suitably detailed fuel handling manual, such that trained personnel can safely operate the fuel bunkering, storage and transfer systems; and
- 18.2.4** the ship shall be provided with suitable emergency procedures.

### 18.3 Maintenance

**18.3.1** Maintenance and repair procedures shall include considerations with respect to the tank location and adjacent spaces (see [Section 5](#)).

**18.3.2** In-service survey, maintenance and testing of the fuel containment system are to be carried out in accordance with the inspection/survey plan required by [6.4.1.8](#).

**18.3.3** The procedures and information shall include maintenance of electrical equipment that is installed in explosion hazardous spaces and areas. The inspection and maintenance of electrical installations in explosion hazardous spaces shall be performed in accordance with a recognized standard<sup>1)</sup>.

---

<sup>1)</sup>Refer to IEC 60079 17:2007 Explosive atmospheres – part 17: Electrical installations inspection and maintenance.

## 18.4 Bunkering operations

### 18.4.1 Responsibilities

.1 Before any bunkering operation commences, the master of the receiving ship or his representative and the representative of the bunkering source (Persons In Charge, PIC) shall:

.1.1 agree in writing the transfer procedure, including cooling down and if necessary, gassing up; the maximum transfer rate at all stages and volume to be transferred;

.1.2 agree in writing action to be taken in an emergency; and

.1.3 complete and sign the bunker safety check-list.

.2 Upon completion of bunkering operations the vessel PIC shall receive and sign a Bunker Delivery Note for the fuel delivered, containing at least the information specified in the [Annex B](#), completed and signed by the bunkering source PIC.

### 18.4.2 Overview of control, automation and safety systems

.1 The fuel handling manual required by [18.2.3](#) shall include but is not limited to:

.1.1 overall operation of the ship from dry-dock to dry-dock, including procedures for system cool down and warm up, bunker loading and, where appropriate, discharging, sampling, inerting and gas freeing;

.1.2 bunker temperature and pressure control and alarm and safety systems;

.1.3 system limitations, cool down rates and maximum fuel storage tank temperatures prior to bunkering, including minimum fuel temperatures, maximum tank pressures, transfer rates, filling limits and sloshing limitations;

.1.4 operation of inert gas systems;

.1.5 firefighting and emergency procedures: operation and maintenance of firefighting systems and use of extinguishing agents;

.1.6 specific fuel properties and special equipment needed for the safe handling of the particular fuel;

.1.7 fixed and portable gas detection operation and maintenance of equipment;

.1.8 emergency shutdown and emergency release systems, where fitted; and

.1.9 a description of the procedural actions to take in an emergency situation, such as leakage, fire or potential fuel stratification resulting in rollover.

.2 A fuel system schematic/piping and instrumentation diagram (P&ID) shall be reproduced and permanently mounted in the vessels' bunker control station and at the bunker station.

### 18.4.3 Pre-bunkering verification

.1 Prior to conducting bunkering operations, pre-bunkering verification including, but not limited to the following, shall be carried out and documented in the bunker safety checklist:

.1.1 all communications methods, including ship shore link (SSL), if fitted;

.1.2 operation of fixed gas and fire detection equipment;

.1.3 operation of portable gas detection equipment;

.1.4 operation of remote controlled valves; and

.1.5 inspection of hoses and couplings.

.2 Documentation of successful verification shall be indicated by the mutually agreed and executed bunkering safety checklist signed by both PIC's.

#### 18.4.4 Ship bunkering source communications

- .1 Communications shall be maintained between the vessel PIC and the bunkering source PIC at all times during the bunkering operation. In the event that communications cannot be maintained, bunkering shall stop and not resume until communications are restored.
- .2 Communication devices used in bunkering shall comply with recognized standards for such devices acceptable to the BKI.
- .3 PIC's shall have direct and immediate communication with all personnel involved in the bunkering operation.
- .4 The ship shore link (SSL) or equivalent means to a bunkering source provided for automatic ESD communications, shall be compatible with the receiving vessel and the delivering facility ESD system<sup>2)</sup>.

#### 18.4.5 Electrical bonding

Hoses, transfer arms, piping and fittings provided by the delivering facility used for bunkering shall be electrically continuous, suitably insulated and shall provide a level of safety compliant with recognized standards<sup>3)</sup>.

#### 18.4.6 Conditions for transfer

- .1 Warning signs shall be posted at the access points to the bunkering area listing fire safety precautions during fuel transfer.
- .2 During the transfer operation, personnel in the bunkering manifold area shall be limited to essential staff only. All staff engaged in duties or working in the vicinity of the operations shall wear appropriate personal protective equipment (PPE). A failure to maintain the required conditions for transfer shall be cause to stop operations and transfer shall not be resumed until all required conditions are met.
- .3 Where bunkering is to take place via the installation of portable tanks, the procedure shall provide an equivalent level of safety as integrated fuel tanks and systems. Portable tanks shall be filled prior to loading on board the vessel and shall be properly secured prior to connection to the fuel system.
- .4 For tanks not permanently installed in the vessel, the connection of all necessary tank systems (piping, controls, safety system, relief system, etc.) to the fuel system of the ship is part of the "bunkering" process and shall be finished prior to ship departure from the bunkering source. Connecting and disconnecting of portable tanks during the sea voyage or manoeuvring is not permitted.

### 18.5 Enclosed space entry

**18.5.1** Under normal operational circumstances, personnel shall not enter fuel tanks, fuel storage hold spaces, void spaces, tank connection spaces or other enclosed spaces where gas or flammable vapours may accumulate, unless the gas content of the atmosphere in such space is determined by means of fixed or portable equipment to ensure oxygen sufficiency and absence of an explosive atmosphere .

**18.5.2** Personnel entering any space designated as a hazardous area shall not introduce any potential source of ignition into the space unless it has been certified gas-free and maintained in that condition.

### 18.6 Inerting and purging of fuel systems

**18.6.1** The primary objective in inerting and purging of fuel systems is to prevent the formation of a combustible atmosphere in, near or around fuel system piping, tanks, equipment and adjacent spaces.

<sup>2)</sup> Refer to ISO 28460, ship-shore interface and port operations.

<sup>3)</sup> Refer to API RP 2003, ISGOTT: International Safety Guide for Oil Tankers and Terminals.

**18.6.2** Procedures for inerting and purging of fuel systems shall ensure that air is not introduced into piping or a tank containing gas atmospheres, and that gas is not introduced into air contained in enclosures or spaces adjacent to fuel systems.

### **18.7 Hot work on or near fuel systems**

**18.7.1** Hot work in the vicinity of fuel tanks, fuel piping and insulation systems that may be flammable, contaminated with hydrocarbons, or that may give off toxic fumes as a product of combustion shall only be undertaken after the area has been secured and proven safe for hot work and all approvals have been obtained.

## Section 19 Training

19.1	General . . . . .	19-1
19.2	Functional requirements . . . . .	19-1

### 19.1 General

The goal of this Section is to ensure that seafarers on board ships to which these Guidelines applies are adequately qualified, trained and experienced.

### 19.2 Functional requirements

Companies shall ensure that seafarers on board ships using gases or other low-flashpoint fuels shall have completed training to attain the abilities that are appropriate to the capacity to be filled and duties and responsibilities to be taken up, taking into account the provisions given in the STCW Convention and Code, as amended.

*This page intentionally left blank*



# Annex A Standard for the Use of Limit State Methodologies in The Design of Fuel Containment Systems of Novel Configuration

A.1	General	A-1
A.2	Design Format	A-1
A.3	Required Analyses	A-2
A.4	Ultimate Limit States	A-3
A.5	Fatigue Limit States	A-6
A.6	Accident Limit States	A-7
A.7	Testing	A-7

## A.1 General

**A.1.1** The purpose of this standard is to provide procedures and relevant design parameters of limit state design of fuel containment systems of a novel configuration in accordance with Section 6.4.16.

**A.1.2** Limit state design is a systematic approach where each structural element is evaluated with respect to possible failure modes related to the design conditions identified in 6.4.1.6. A limit state can be defined as a condition beyond which the structure, or part of a structure, no longer satisfies the regulations.

**A.1.3** The limit states are divided into the three following categories:

- .1 Ultimate Limit States (ULS), which correspond to the maximum load-carrying capacity or, in some cases, to the maximum applicable strain, deformation or instability in structure resulting from buckling and plastic collapse; under intact (undamaged) conditions;
- .2 Fatigue Limit States (FLS), which correspond to degradation due to the effect of cyclic loading; and
- .3 Accident Limit States (ALS), which concern the ability of the structure to resist accident situations.

**A.1.4** Section 6.4.1 through to Section 6.4.14 shall be complied with as applicable depending on the fuel containment system concept.

## A.2 Design Format

**A.2.1** The design format in this standard is based on a Load and Resistance Factor Design format. The fundamental principle of the Load and Resistance Factor Design format is to verify that design load effects,  $L_d$ , do not exceed design resistances,  $R_d$ , for any of the considered failure modes in any scenario:

$$L_d \leq R_d$$

A design load  $F_{dk}$  is obtained by multiplying the characteristic load by a load factor relevant for the given load category:

$$F_{dk} = \gamma_f \cdot F_k$$

where:

- $\gamma_f$  = load factor; and  
 $F_k$  = the characteristic load as specified in Section 6.4.9 through to Section 6.4.12.

A design load effect  $L_d$  (e.g. stresses, strains, displacements and vibrations) is the most unfavourable combined load effect derived from the design loads, and may be expressed by:

$$L_d = q (F_{d1}, F_{d2}, \dots, F_{dN})$$

where  $q$  denotes the functional relationship between load and load effect determined by structural analyses

The design resistance  $R_d$  is determined as follows:

$$R_d = \frac{R_k}{\gamma_R \cdot \gamma_C}$$

where:

- $R_k$  = the characteristic resistance. In case of materials covered by Section 7, it may be, but not limited to, specified minimum yield stress, specified minimum tensile strength, plastic resistance of cross sections, and ultimate buckling strength;
- $\gamma_R$  = the resistance factor, defined as  $\gamma_R = \gamma_m \cdot \gamma_s$ ;
- $\gamma_m$  = the partial resistance factor to take account of the probabilistic distribution of the material properties (material factor);
- $\gamma_s$  = the partial resistance factor to take account of the uncertainties on the capacity of the structure, such as the quality of the construction, method considered for determination of the capacity including accuracy of analysis; and
- $\gamma_C$  = the consequence class factor, which accounts for the potential results of failure with regard to release of fuel and possible human injury.

**A.2.2** Fuel containment design shall take into account potential failure consequences. Consequence classes are defined in Table A.1, to specify the consequences of failure when the mode of failure is related to the Ultimate Limit State, the Fatigue Limit State, or the Accident Limit State.

**Table A.1: Consequence classes**

Consequence class	Definition
Low	Failure implies minor release of the fuel.
Medium	Failure implies release of the fuel and potential for human injury.
High	Failure implies significant release of the fuel and high potential for human injury/fatality.

### A.3 Required Analyses

**A.3.1** Three dimensional finite element analyses shall be carried out as an integrated model of the tank and the ship hull, including supports and keying system as applicable. All the failure modes shall be identified to avoid unexpected failures. Hydrodynamic analyses shall be carried out to determine the particular ship accelerations and motions in irregular waves, and the response of the ship and its fuel containment systems to these forces and motions.

**A.3.2** Buckling strength analyses of fuel tanks subject to external pressure and other loads causing compressive stresses shall be carried out in accordance with recognized standards. The method shall adequately account for the difference in theoretical and actual buckling stress as a result of plate out of flatness, plate edge misalignment, straightness, ovality and deviation from true circular form over a specified arc or chord length, as relevant.

**A.3.3** Fatigue and crack propagation analysis shall be carried out in accordance with paragraph [A.5.1](#) of this standard.

#### **A.4 Ultimate Limit States**

**A.4.1** Structural resistance may be established by testing or by complete analysis taking account of both elastic and plastic material properties. Safety margins for ultimate strength shall be introduced by partial factors of safety taking account of the contribution of stochastic nature of loads and resistance (dynamic loads, pressure loads, gravity loads, material strength, and buckling capacities).

**A.4.2** Appropriate combinations of permanent loads, functional loads and environmental loads including sloshing loads shall be considered in the analysis. At least two load combinations with partial load factors as given in [Table A.2](#) shall be used for the assessment of the ultimate limit states.

**Table A.2: Partial load factors**

<b>Load combination</b>	<b>Permanent loads</b>	<b>Functional loads</b>	<b>Environmental loads</b>
'a'	1,1	1,1	0,7
'b'	1,0	1,0	1,3

The load factors for permanent and functional loads in load combination 'a' are relevant for the normally well-controlled and/or specified loads applicable to fuel containment systems such as vapour pressure, fuel weight, system self-weight, etc. Higher load factors may be relevant for permanent and functional loads where the inherent variability and/or uncertainties in the prediction models are higher.

**A.4.3** For sloshing loads, depending on the reliability of the estimation method, a larger load factor may be required by the BKI.

**A.4.4** In cases where structural failure of the fuel containment system are considered to imply high potential for human injury and significant release of fuel, the consequence class factor shall be taken a  $\gamma_C = 1,2$ . This value may be reduced if it is justified through risk analysis and subject to the approval by the BKI. The risk analysis shall take account of factors including, but not limited to, provision of full or partial secondary barrier to protect hull structure from the leakage and less hazards associated with intended fuel. Conversely, higher values may be fixed by the BKI, for example, for ships carrying more hazardous or higher pressure fuel. The consequence class factor shall in any case not be less than 1,0.

**A.4.5** The load factors and the resistance factors used shall be such that the level of safety is equivalent to that of the fuel containment systems as described in sections [6.4.2.1](#) to [6.4.2.5](#). This may be carried out by calibrating the factors against known successful designs.

**A.4.6** The material factor  $\gamma_m$  shall in general reflect the statistical distribution of the mechanical properties of the material, and needs to be interpreted in combination with the specified characteristic mechanical properties. For the materials defined in [Section 6](#), the material factor  $\gamma_m$  may be taken as:

1,1 when the characteristic mechanical properties specified by the BKI typically represents the lower 2,5% quantile in the statistical distribution of the mechanical properties; or

1,0 when the characteristic mechanical properties specified by the BKI represents a sufficiently small quantile such that the probability of lower mechanical properties than specified is extremely low and can be neglected.

**A.4.7** The partial resistance factors  $\gamma_{si}$  shall in general be established based on the uncertainties in the capacity of the structure considering construction tolerances, quality of construction, the accuracy of the analysis method applied, etc.

**.1** For design against excessive plastic deformation using the limit state criteria given in paragraph A.4.8 of this standard, the partial resistance factors  $\gamma_{si}$  shall be taken as follows:

$$\begin{aligned}\gamma_{s1} &= 0,76 \cdot \left( \frac{B}{\kappa_1} \right) \\ \gamma_{s2} &= 0,76 \cdot \left( \frac{D}{\kappa_2} \right) \\ \kappa_1 &= \text{Min} \left( \frac{R_m}{R_e} \cdot \frac{B}{A}; 1,0 \right) \\ \kappa_2 &= \text{Min} \left( \frac{R_m}{R_e} \cdot \frac{D}{C}; 1,0 \right)\end{aligned}$$

Factors A, B, C and D are defined in 6.4.15.2.3.1.  $R_m$  and  $R_e$  are defined in 6.4.12.1.1.3.

The partial resistance factors given above are the results of calibration to conventional type B independent tanks.

#### **A.4.8 Design against excessive plastic deformation**

**.1** Stress acceptance criteria given below refer to elastic stress analyses.

**.2** Parts of fuel containment systems where loads are primarily carried by membrane response in the structure shall satisfy the following limit state criteria:

$$\begin{aligned}\sigma_m &\leq f \\ \sigma_L &\leq 1,5f \\ \sigma_b &\leq 1,5F \\ \sigma_L + \sigma_b &\leq 1,5F \\ \sigma_m + \sigma_b &\leq 1,5F \\ \sigma_m + \sigma_b + \sigma_g &\leq 3,0F \\ \sigma_L + \sigma_b + \sigma_g &\leq 3,0F\end{aligned}$$

where:

$$\begin{aligned}\sigma_m &= \text{equivalent primary general membrane stress;} \\ \sigma_L &= \text{equivalent primary local membrane stress;} \\ \sigma_b &= \text{equivalent primary bending stress;} \\ \sigma_g &= \text{equivalent secondary stress;} \\ f &= \frac{R_e}{\gamma_{s1} \cdot \gamma_m \cdot \gamma_c} \\ F &= \frac{R_e}{\gamma_{s2} \cdot \gamma_m \cdot \gamma_c}\end{aligned}$$

**Guidance Note:**

The stress summation described above shall be carried out by summing up each stress component ( $\sigma_x, \sigma_y, \tau_{xy}$ ), and subsequently the equivalent stress shall be calculated based on the resulting stress components as shown in the example below.

$$\sigma_L + \sigma_b = \sqrt{(\sigma_{Lx} + \sigma_{bx})^2 - (\sigma_{Lx} + \sigma_{bx})(\sigma_{Ly} + \sigma_{by}) + (\sigma_{Ly} + \sigma_{by})^2 + 3(\tau_{Lxy} + \tau_{bxy})^2}$$

.3 Parts of fuel containment systems where loads are primarily carried by bending of girders, stiffeners and plates, shall satisfy the following limit state criteria:

$$\sigma_{ms} + \sigma_{bp} \leq 1,25F \quad (\text{see notes 1, 2})$$

$$\sigma_{ms} + \sigma_{bp} + \sigma_{bs} \leq 1,25F \quad (\text{see notes 2})$$

$$\sigma_{ms} + \sigma_{bp} + \sigma_{bs} + \sigma_{bt} + \sigma_g \leq 3,0F$$

where:

$\sigma_{ms}$  = equivalent section membrane stress in primary structure

$\sigma_{bp}$  = equivalent membrane stress in primary structure and stress in secondary and tertiary structure caused by bending of primary structure

$\sigma_{bs}$  = section bending stress in secondary structure and stress in tertiary structure caused by bending of secondary structure

$\sigma_{bt}$  = section bending stress in tertiary structure

$\sigma_g$  = equivalent secondary stress;

$$f = \frac{R_e}{\gamma_{s1} \cdot \gamma_m \cdot \gamma_c}$$

$$F = \frac{R_e}{\gamma_{s2} \cdot \gamma_m \cdot \gamma_c}$$

The stresses  $\sigma_{ms}$ ,  $\sigma_{bp}$ ,  $\sigma_{bs}$ , and  $\sigma_{bt}$  are defined in 4.8.4.

**Note:**

1. The sum of equivalent section membrane stress and equivalent membrane stress in primary structure ( $\sigma_{ms} + \sigma_{bp}$ ) will normally be directly available from three-dimensional finite element analyses.

2. The coefficient, 1,25, may be modified by the BKI considering the design concept, configuration of the structure, and the methodology used for calculation of stresses.

**Guidance Note:**

The stress summation described above shall be carried out by summing up each stress component ( $\sigma_x$ ,  $\sigma_y$ ,  $\tau_{xy}$ ), and subsequently the equivalent stress shall be calculated based on the resulting stress components.

Skin plates shall be designed in accordance with the requirements of the BKI. When membrane stress is significant, the effect of the membrane stress on the plate bending capacity shall be appropriately considered in addition.

**.4 Section stress categories**

Normal stress is the component of stress normal to the plane of reference.

Equivalent section membrane stress is the component of the normal stress that is uniformly distributed and equal to the average value of the stress across the cross section of the structure under consideration. If this is a simple shell section, the section membrane stress is identical to the membrane stress defined in paragraph A.4.8.2 of this standard.

Section bending stress is the component of the normal stress that is linearly distributed over a structural section exposed to bending action, as illustrated in Figure A.1.

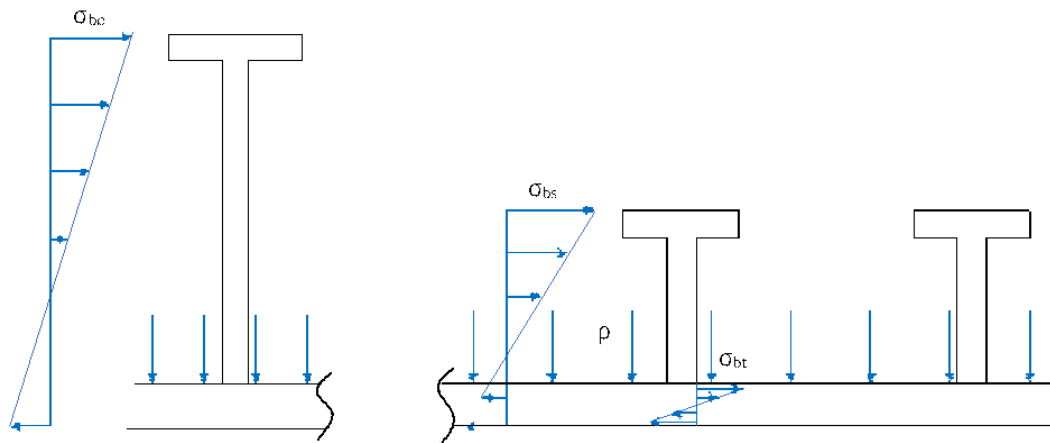

**Figure A.4.1: Definition of the three categories of section stress  
(Stresses  $\sigma_{bp}$  and  $\sigma_{bs}$  are normal to the cross section shown)**

- $\sigma_{bp}$  = equivalent membrane stress in primary structure
- $\sigma_{bs}$  = section bending stress in secondary structure
- $\sigma_{bt}$  = section bending stress in tertiary structure

**A.4.9** The same factors  $\gamma_C$ ,  $\gamma_m$ ,  $\gamma_{SI}$  shall be used for design against buckling unless otherwise stated in the applied recognized buckling standard. In any case the overall level of safety shall not be less than given by these factors.

**A.5 Fatigue Limit States**

**A.5.1** Fatigue design condition as described in 6.4.12.2 shall be complied with as applicable depending on the fuel containment system concept. Fatigue analysis is required for the fuel containment system designed under 6.4.16 and this standard.

**A.5.2** The load factors for FLS shall be taken as 1,0 for all load categories.

**A.5.3** Consequence class factor  $\gamma_C$  and resistance factor  $\gamma_R$  shall be taken as 1,0.

**A.5.4** Fatigue damage shall be calculated as described in 6.4.12.2.2 to 6.4.12.2.5. The calculated cumulative fatigue damage ratio for the fuel containment systems shall be less than or equal to the values given in Table A.3.

**Table A.3: Maximum allowable cumulative fatigue damage ratio**

C <sub>w</sub>	Consequence class		
	Low	Medium	High
	1,0	0,5	0,5*
*Note: Lower value shall be used in accordance with 6.4.12.2.7 to 6.4.12.2.9, depending on the detectability of defect or crack, etc.			

**A.5.5** Lower values may be fixed by BKI.

**A.5.6** Crack propagation analyses are required in accordance with 6.4.12.2.6 to 6.4.12.2.9. The analysis shall be carried out in accordance with methods laid down in a standard recognized by the BKI.

## **A.6 Accident Limit States**

**A.6.1** Accident design condition as described in 6.4.12.3 shall be complied with as applicable, depending on the fuel containment system concept.

**A.6.2** Load and resistance factors may be relaxed compared to the ultimate limit state considering that damages and deformations can be accepted as long as this does not escalate the accident scenario.

**A.6.3** The load factors for ALS shall be taken as 1,0 for permanent loads, functional loads and environmental loads.

**A.6.4** Loads mentioned in 6.4.9.3.3.8 and 6.4.9.5 need not be combined with each other or with environmental loads, as defined in 6.4.9.4.

**A.6.5** Resistance factor  $\gamma_R$  shall in general be taken as 1,0.

**A.6.6** Consequence class factors  $\gamma_C$  shall in general be taken as defined in paragraph A.4.4 of this standard, but may be relaxed considering the nature of the accident scenario.

**A.6.7** The characteristic resistance  $R_k$  shall in general be taken as for the ultimate limit state, but may be relaxed considering the nature of the accident scenario.

**A.6.8** Additional relevant accident scenarios shall be determined based on a risk analysis.

## **A.7 Testing**

**A.7.1** Fuel containment systems designed according to this standard shall be tested to the same extent as described in 16.2, as applicable depending on the fuel containment system concept.

*This page intentionally left blank*



## Annex B LNG Bunker Delivery Note

### LNG-BUNKER DELIVERY NOTE<sup>1)</sup> LNG AS FUEL FOR

SHIP NAME: \_\_\_\_\_ IMO NO: \_\_\_\_\_

Date of delivery:

#### 1) LNG-Properties

Methane Number <sup>2)</sup>	-	
Lower calorific (heating) value	MJ/kg	
Higher calorific (heating) value	MJ/kg	
Wobbe Indices Ws/Wi	MJ/m <sup>3</sup>	
Density	Kg/m <sup>3</sup>	
Pressure	MPa (abs)	
LNG temperature delivered	°C	
LNG temperature in storage tank(s)	°C	
Pressure in storage tank(s)	MPa (abs)	

#### 2) LNG-Composition

Methane, CH <sub>4</sub>	%(kg/kg)	
Ethane, C <sub>2</sub> H <sub>6</sub>	%(kg/kg)	
Propane, C <sub>3</sub> H <sub>8</sub>	%(kg/kg)	
Isobutane, <i>i</i> C <sub>4</sub> H <sub>10</sub>	%(kg/kg)	
N-Butane, <i>n</i> C <sub>4</sub> H <sub>10</sub>	%(kg/kg)	
Pentane, C <sub>5</sub> H <sub>12</sub>	%(kg/kg)	
Hexane, C <sub>6</sub> H <sub>14</sub>	%(kg/kg)	
Heptane, C <sub>7</sub> H <sub>16</sub>	%(kg/kg)	
Nitrogen, N <sub>2</sub>	%(kg/kg)	
Sulphur, S	%(kg/kg)	
Negligible < 5ppm hydrogen sulphide, hydrogen, ammonia, chlorine, fluorine, water		

3) Net Total delivered: \_\_\_\_\_ t, \_\_\_\_\_ MJ, \_\_\_\_\_ m<sup>3</sup>

Net Liquid delivered: \_\_\_\_\_ GJ

#### 4) Signature(s)

Supplier Company Name, contact details: \_\_\_\_\_

Signature: \_\_\_\_\_ Place/Port: \_\_\_\_\_ date: \_\_\_\_\_

Receiver: \_\_\_\_\_

<sup>1)</sup> The LNG properties and composition allow the operator to act in accordance with the known properties of the gas and any operational limitations linked to that

<sup>2)</sup> Preferably above 70 and referring to the used methane number calculation method in DIN EN 16726. This does not necessarily reflect the methane number that goes into the engine

*This page intentionally left blank*